

GLF71311

Ultra-Efficient, I_QSmart™ Load Switch with Slew Rate Control

DESCRIPTION

The evaluation board features the GLF71311 ultra-thin, ultra-efficiency 2A slew rate controlled load switch suitable for applications that control current power rails in wearables and IoT devices.

The GLF71311 is fully integrated I_QSmart™ with a fixed slew rate control to limit the inrush current to minimize input voltage droop, and offer an ultra-low R_{ON} in 0.97mm x 0.97mm x 0.55mm Chip Scale Package.

GLF71311 FEATURES

- Wide Input Range 1.1V to 5.5V
- Low R_{ON} = 31mΩ (Typ.) at 5.5V_{IN}
- Up to 2A Continuous Current
- Ultra-Low I_Q : 7nA Typ at 5.5V_{IN}
- Ultra-Low I_{SD} : 25nA Typ at 5.5V_{IN}
- 335us Rise Time at 3.3V_{IN}
- Internal EN Pull-Down Resistor
- Optional Output Pull Down
- 0.97mm x 0.97mm Wafer Level Chip Scale Package

PRODUCT TABLE

Eval Board Ordering Info	Part Number	Top Mark	R _{ON} (Typ.) @ 5.5V _{in}	Output Discharge	EN Activity
EV002-GLF71310	GLF71310	BA	31 mΩ	NA	High
EV002-GLF71311	GLF71311	BC	31 mΩ	85Ω	High
EV002-GLF71312	GLF71312	BD	31 mΩ	NA	Low
EV002-GLF71313	GLF71313	BE	31 mΩ	85Ω	Low

Note) Contact GLF for more information on alternate device delivery and availability

EVALUATION BOARD & DEVICE PACKAGE

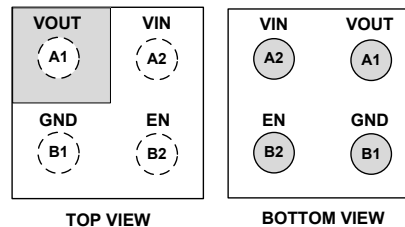

Pin #	Name	Description
A1	V _{OUT}	Switch Output
A2	V _{IN}	Switch Input. Supply Voltage for IC
C1	GND	Ground
C2	EN	Enable to control the switch

GLF71311T

Ultra-Thin, I_QSmart™ Load Switch with Slew Rate Control

DESCRIPTION

The evaluation board features the GLF71311T ultra-thin, ultra-efficiency 2A slew rate controlled load switch suitable for applications that control current power rails in wearables and IoT devices.

The GLF71311T is the fully integrated I_QSmart™ with a fixed slew rate control to limit the inrush current to minimize input voltage droop, and offer an ultra-low R_{ON} in 0.97mm x 0.97mm x 0.35mm WLCSP.

GLF71311T FEATURES

- Wide Input Range 1.1V to 5.5V
- Low R_{ON} = 31mΩ (Typ.) at 5.5V_{IN}
- Up to 2A Continuous Current
- Ultra-Low I_Q : 7nA Typ at 5.5V_{IN}
- Ultra-Low I_{SD} : 28nA Typ at 5.5V_{IN}
- 335us Rise Time at 3.3V_{IN}
- Internal EN Pull-Down Resistor
- Optional Output Pull Down
- 0.97mm x 0.97mm x 0.35mm Wafer Level Chip Scale Package

PRODUCT TABLE

Eval Board Ordering Info	Part Number	Top Mark	R _{ON} (Typ.) @ 5.5V _{in}	Output Discharge	EN Activity
EV002-GLF71310T	GLF71310T	BA	31 mΩ	NA	High
EV002-GLF71311T	GLF71311T	BC	31 mΩ	85Ω	High
EV002-GLF71312T	GLF71312T	BD	31 mΩ	NA	Low
EV002-GLF71313T	GLF71313T	BE	31 mΩ	85Ω	Low

Note) Contact GLF for more information on alternate device delivery and availability

EVALUATION BOARD & DEVICE PACKAGE

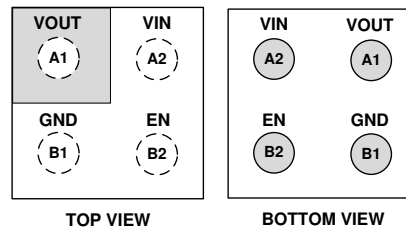

Pin #	Name	Description
A1	V _{OUT}	Switch Output
A2	V _{IN}	Switch Input. Supply Voltage for IC
C1	GND	Ground
C2	EN	Enable to control the switch

QUICK START GUIDE

The evaluation board EV002 is easy to set up to evaluate the performance of GLF71311T.

1. Preset the input power supply to the desired voltage between 1.1V to 5.5V.
2. The load resistor, $RL1=500\Omega$, has been populated on the bottom of the PC board. Short the J2 to use the $RL1=500\Omega$ or $RL2$ which is not populated. To increase the output current, connect an electronic load to VOUT and GND. The output current for the GLF71311T is rated for 2A maximum output continuous current. Please ensure this absolute maximum is not exceeded.
3. Connect the positive and negative terminals of the input power supply to VIN and GND terminals respectively. VIN_Sense and VOUT_Sense can be used for measurement points.
4. Turn on the input power supply.
5. Configure the J1, EN jumper as required. Note - GLF71311T has an internal EN pull-down resistor to ensure the part is in a defined state.

TEST SETUP

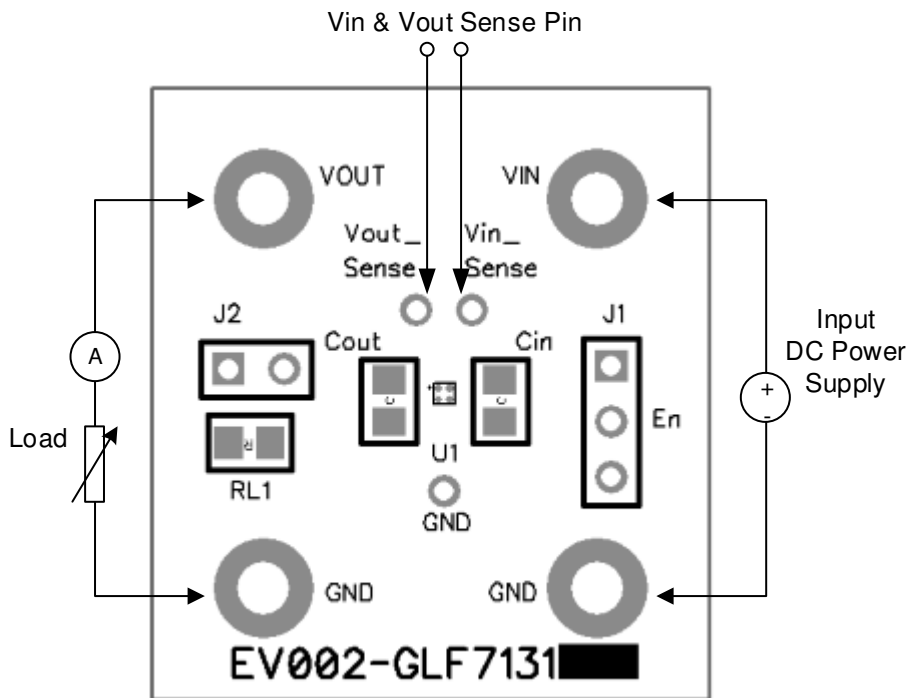

SCHEMATIC

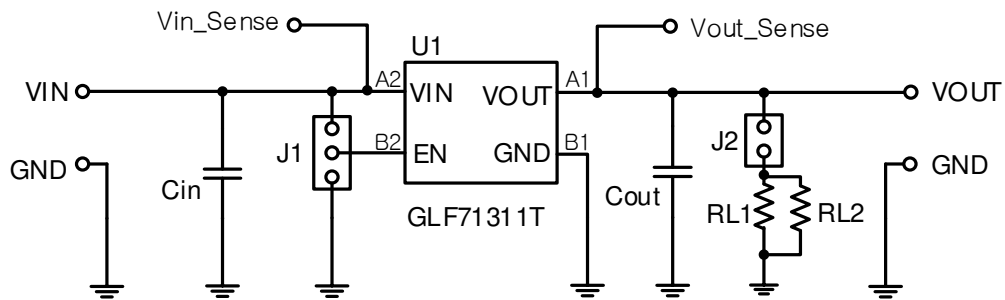

BILL OF MATERIALS

Qty	Reference	Value	Part Description	Manufacturer/Part Number
1	U1	GLF71311T	GLF71311T	GLF Integrated Power
1	Cin	1.0uF	Cap., X7R, 16V, 5% 0805	AVX # 0805YA103JAT2A
1	Cout	0.1uF	Cap., X7R, 16V, 5% 0805	Kemet # C0805C104J4RACTU
1	RL1	500Ω	Load Resistor	Panasonic # ERG-3SJ110A
	RL2	-	Load Resistor	Not populated on the bottom
2	J1-2	Jumper	Jumper	

PRINTED CIRCUIT BOARD LAYOUT

Fig 1. Top Layer

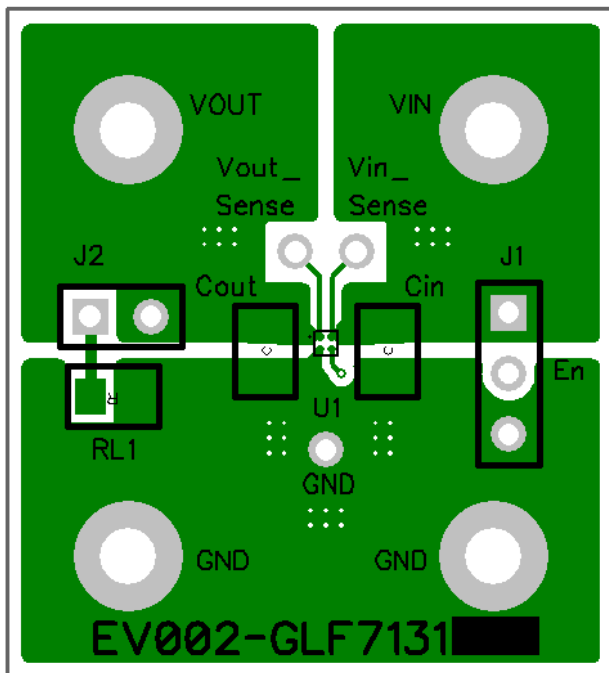
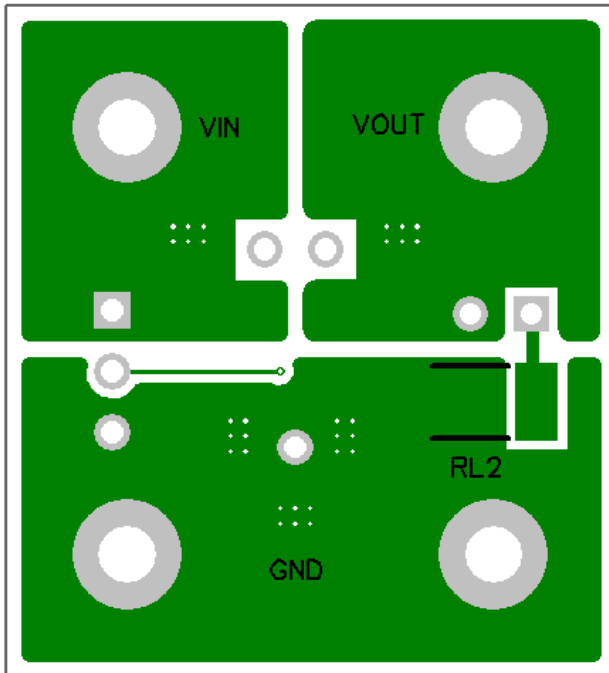

Fig 2. Bottom Layer



NOTICE: The evaluation board provided by GLF Integrated Power is intended for use for ENGINEERING DEVELOPMENT, OR EVALUATION PURPOSES ONLY and is not for any commercial use. The user assumes all responsibility and liability for proper and safe handling of the goods.