

CMX639P6 package discontinued



CMX639 Consumer / Commercial CVSD Digital Voice Codec

D/639/3 February 2005

Provisional Issue

Features

- **Single Chip Full Duplex CVSD codec**
 - Integrated Input and Output Filters
 - Robust Coding for Wireless Links
 - Programmable Sampling Clocks
 - 3 and 4 bit Companding Algorithms
- **Low Power/Small Size for Portable Devices**
 - 1.9mA/2.75mA typ. @ 3.0V/5.0V
 - 3.0V to 5.5V Operation
 - Powersave Mode

Applications

- **Consumer and Business Handheld Devices**
- **Digital Voice Appliances**
 - Spread Spectrum Wireless
 - Cordless Phones
 - Voice Recording and Storage
 - Delay Lines
- **Time Domain Scramblers**
- **Multiplexers and Switches**

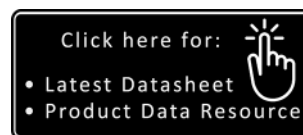
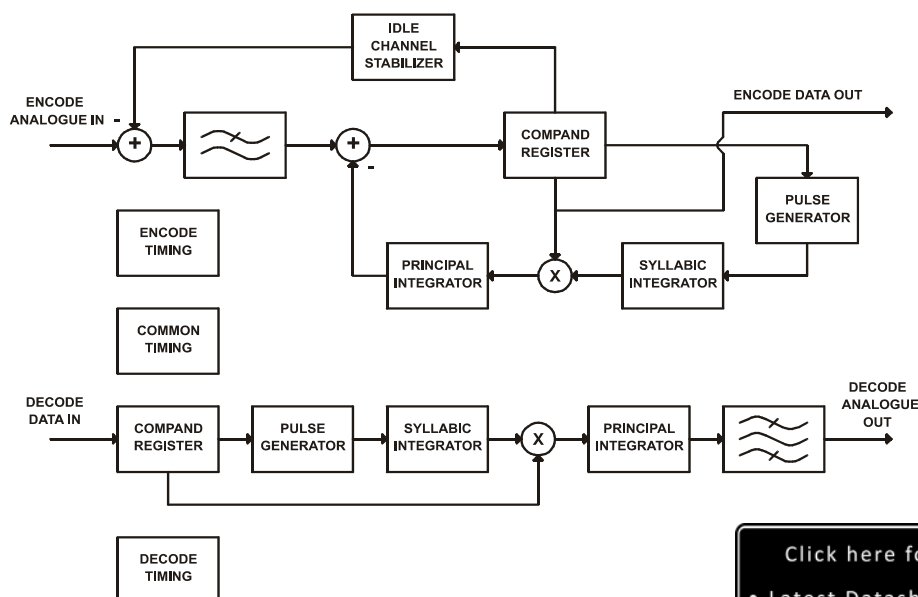

1.1 Brief Description

The CMX639 is a Continuously Variable Slope Delta Modulation (CVSD) full duplex CODEC for use in consumer and commercial digital voice communication systems. With its robust and selectable coding algorithms, low cost, very low power, and small size, the CMX639 is ideal for use in a wide variety of consumer and business digital voice applications. Its completely integrated CODEC simplifies design and eliminates the costs, complexity and risk of external filters and software algorithms.

8kbps to 128kbps data/sampling clock rates are supported both via external clock signals or internally generated, programmable clocks. Internal data/sampling clocks are derived from an on-chip reference oscillator that uses an external clock crystal. An internal data/sampling clock output signal is provided to synchronize external circuits, if desired. Multiplexer applications are also well supported by the encoder output's three-state/high impedance enable feature.

The CMX639 operates from 2.7V to 5.5V supplies and is available in the following packages: 24-pin TSSOP (CMX639E2), 16-pin SOIC (CMX639D4) and 22-pin PDIP (CMX639P6).

CMX639P6 package discontinued

<u>Section</u>	CONTENTS	<u>Page</u>
1.0	Features and Applications	1
1.1	Brief Description	1
1.2	Block Diagram	3
1.3	Signal List	4
1.4	External Components.....	6
1.5	General Description	7
1.6	Application Notes	7
1.7	Performance Specification.....	8
1.7.1	Electrical Performance.....	8
1.7.2	Packaging	15

CMX639P6 package discontinued

1.2 Block Diagram

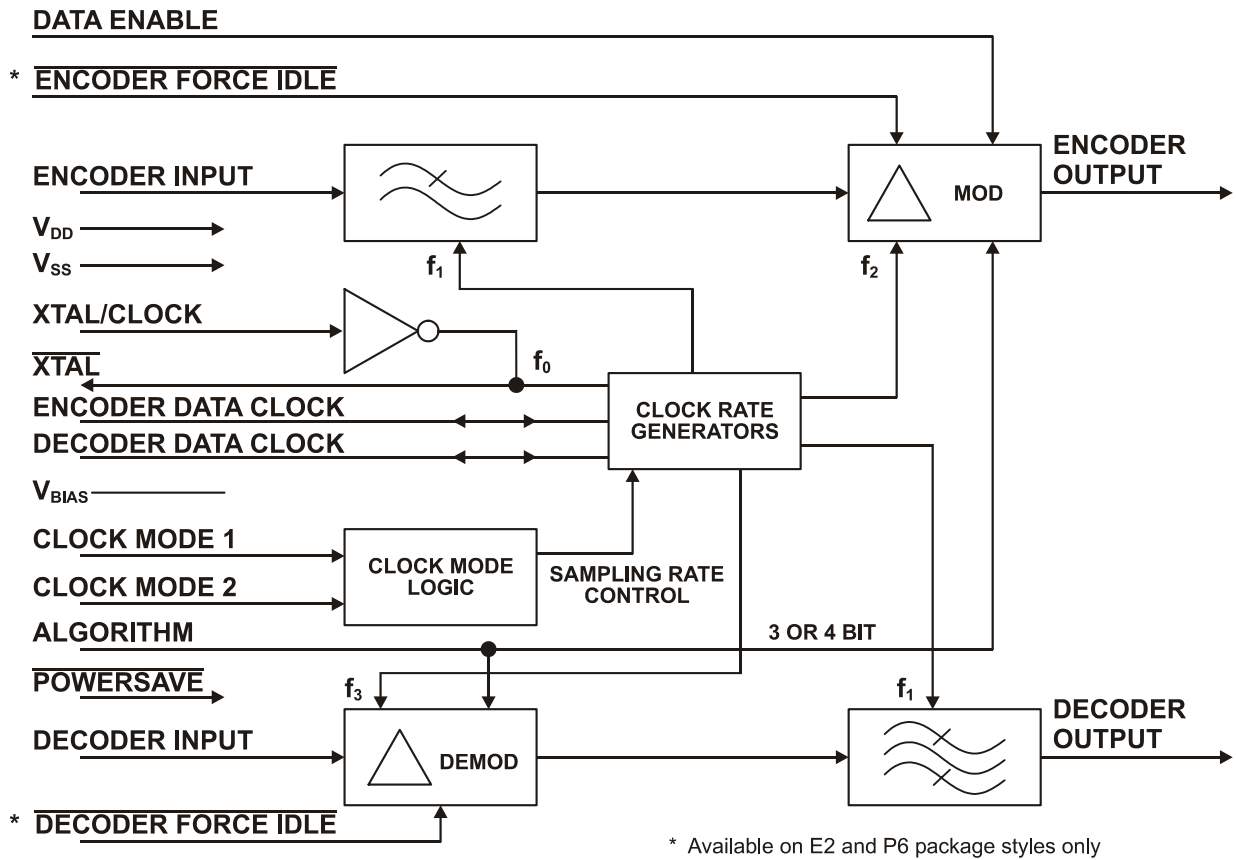

Figure 1 Block Diagram

CMX639P6 package discontinued

1.3 Signal List

P6 22-pin PDIP	E2 24-pin TSSOP	D4 16-pin SOIC	Signal Name	Type	Description
1	1	1	Xtal/Clock	input	Input to the clock oscillator inverter. A 1.024MHz Xtal input or externally derived clock is injected here.
	2		N/C		No Connection
2	3	2	$\overline{\text{Xtal}}$	output	The 1.024 MHz output of the clock oscillator inverter.
3	4		N/C		No Connection
4	5	3	Encoder Data Clock	input/ output	A logic I/O port. External encode clock input or internal data clock output. Clock frequency is dependent upon Clock Mode 1 and 2 inputs and Xtal frequency. Note: No internal pull-up is provided. See Table 3.
5	6	4	Encoder Output	output	The encoder digital output. This is a three-state output whose condition is set by the Data Enable and Powersave inputs. See Table 2.
6	7	Not present	Encoder Force Idle	input	When this pin is at a logical '0' the encoder is forced to an idle state and the encoder digital output is '0101...', a perfect idle pattern. When this pin is a logical '1' the encoder encodes as normal. Internal 1M Ω pull-up.
7	8	5	Data Enable	input	Data is made available at the encoder output pin by control of this input. See Encoder Output pin. Internal 1 M Ω pull-up.
8	9		N/C		No Connection
9	10	6	V _{BIAS}		Normally at V _{DD} /2, this pin should be externally decoupled by capacitor C4. Internally pulled to V _{SS} when Powersave is a logical '0'.
10	11	7	Encoder Input	input	The analog signal input. Internally biased at V _{DD} /2, this input requires an external coupling capacitor. The source impedance driving the coupling capacitor should be less than 1k Ω . A lower driving source impedance will reduce encoder output channel noise levels.
11	12	8	V _{SS}	power	Negative Supply
12	13		N/C		No Connection
13	14	9	Decoder Output	output	The recovered analog signal is output at this pin. It is the buffered output of a lowpass filter and requires external components. During 'Powersave' this output is open circuit.
14	15		N/C		No Connection

CMX639P6 package discontinued

P6 22-pin PDIP	E2 24-pin TSSOP	D4 16-pin SOIC	Signal Name	Type	Description
15	16	10	$\overline{\text{Powersave}}$	Input	A logic '0' at this pin puts most parts of the codec into a quiescent, non-operational state. When at a logical '1', the codec operates normally. Internal 1 M Ω pull-up.
	17		N/C		No Connection
16	18	Not present	$\overline{\text{Decoder Force Idle}}$	input	A logic '0' at this pin gates a '0101...' pattern internally to the decoder so that the Decoder Output goes to $V_{DD}/2$. When this pin is a logical '1' the decoder operates as normal. Internal 1M Ω pull-up.
17	19	11	Decoder Input	input	The received digital signal input. Internal 1 M Ω pull-up.
18	20	12	Decoder Data Clock	input/ output	A logic I/O port. External decode clock input or internal data clock output. Clock frequency is dependent upon Clock Mode 1 and 2 inputs and Xtal frequency. Note: No internal pull-up is provided. See Table 3.
19	21	13	Algorithm	input	A logic '1' at this pin sets this device for a 3-bit companding algorithm. A logical '0' sets a 4-bit companding algorithm. Internal 1 M Ω pull-up.
20	22	14	Clock Mode 2	input	Clock rates refer to $f = 1.024\text{MHz}$ Xtal/Clock input. During internal operation the data clock frequencies are available at these ports for external circuit synchronization. Independent or common data rate inputs to Encode and Decode data clock ports may be employed in the External Clocks mode. Internal 1M Ω pull-ups. See Table 3.
21	23	15	Clock Mode 1	input	
22	24	16	V_{DD}	power	Positive Supply. A single 3.0V to 5.5V supply is required. This pin should be externally decoupled to V_{SS} by capacitor C5.

CMX639P6 package discontinued

1.4 External Components

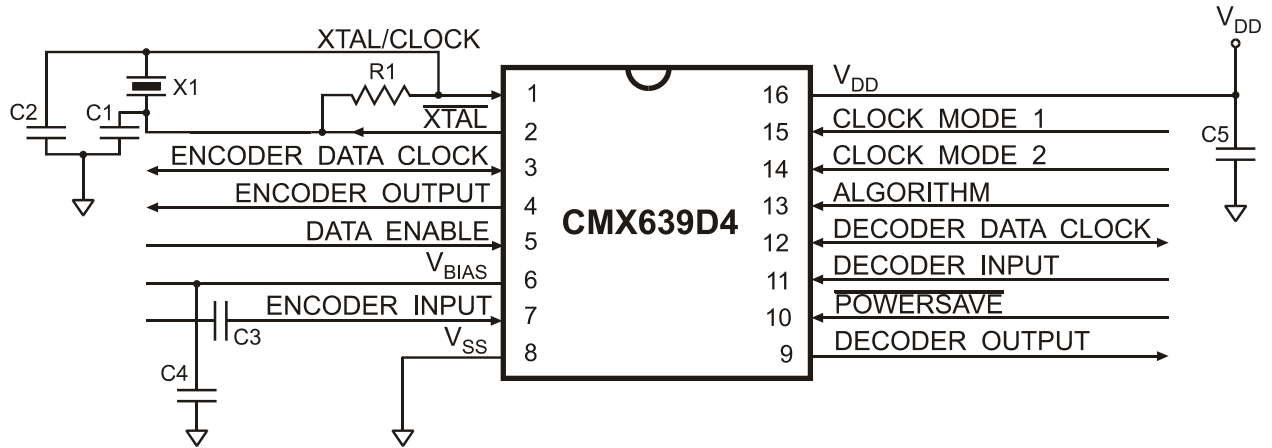

Figure 2 Recommended External Connections

R1	Note 1	1MΩ	±10%	C4	Note 4	1.0μF	±20%
C1	Note 2	33pF	±20%	C5	Note 5	1.0μF	±20%
C2	Note 2	33pF	±20%	X1	Note 6, 7	1.024MHz	
C3	Note 3	1.0μF	±20%				

Table 1 Recommended External Components

Notes:

- Oscillator inverter bias resistor
- Xtal circuit load capacitor
- The drive source impedance connected to the coupling capacitor's input node, rather than the CMX639 ENCODER INPUT pin node, should be less than 1kΩ. Output idle channel noise levels will improve with even lower source impedances driving the coupling capacitor's input node.
- Bias decoupling capacitor
- V_{DD} decoupling capacitor
- A 1.024MHz Xtal/Clock input will yield exactly 16kbps/32kbps/64kbps internally generated data clock rates
- For best results, a crystal oscillator design should drive the clock inverter input with signal levels of at least 40% of V_{DD}, peak to peak. Tuning fork crystals generally cannot meet this requirement. To obtain crystal oscillator design assistance, please consult your crystal manufacturer.

CMX639P6 package discontinued

1.5 General Description

Data Enable	Powersave	Encoder Output
1	1	Enable
0	don't care	High Z (open circuit)
1	0	V _{SS}

Table 2 Encoder Output

Clock Mode 1	Clock Mode 2	Data/Sampling Clock Rate (CLOCK/XTAL = f = 1.024MHz)	Example for f = 1.024MHz
0	0	External Clocks	External Clocks
0	1	Internally generated @ f/16	Internally generated @ 64kbps
1	0	Internally generated @ f/32	Internally generated @ 32kbps
1	1	Internally generated @ f/64	Internally generated @ 16kbps

Table 3 Clock Modes and Pins

1.6 Application Notes

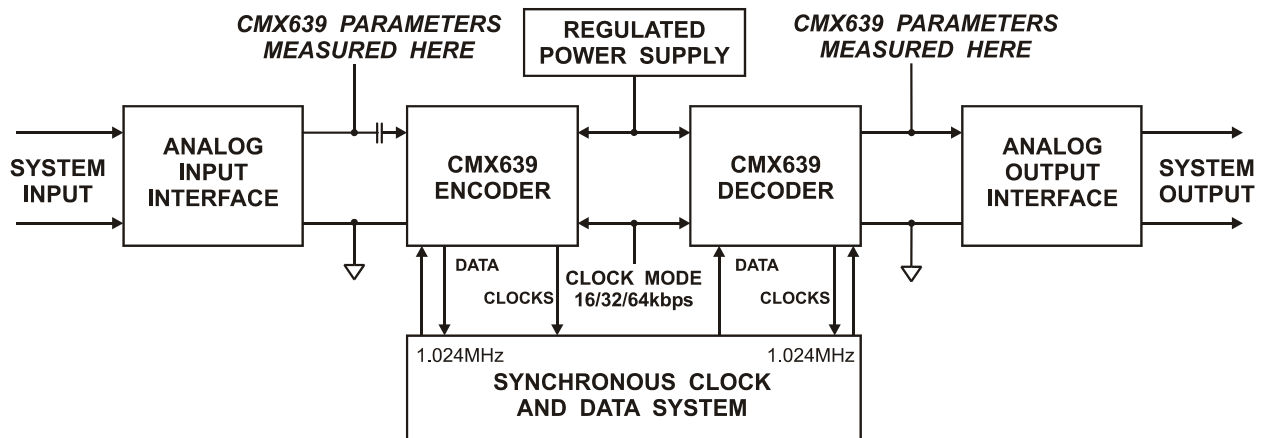

Figure 3 System Configuration using the CMX639

CMX639P6 package discontinued

1.7 Performance Specification

1.7.1 Electrical Performance

1.7.1.1 Absolute Maximum Ratings

Exceeding these maximum ratings can result in damage to the device.

	Min.	Max.	Units
Supply ($V_{DD} - V_{SS}$)	-0.3	7.0	V
Voltage on any pin to V_{SS}	-0.3	$V_{DD} + 0.3$	V
Current into or out of V_{DD} and V_{SS} pins	-30	+30	mA
Current into or out of any other pin	-20	+20	mA

P6 Package	Min.	Max.	Units
Total Allowable Power Dissipation at $T_{amb} = 25^{\circ}\text{C}$		800	mW
... Derating		10	mW/ $^{\circ}\text{C}$
Storage Temperature	-40	+125	$^{\circ}\text{C}$
Operating Temperature	-40	+85	$^{\circ}\text{C}$

E2 Package	Min.	Max.	Units
Total Allowable Power Dissipation at $T_{amb} = 25^{\circ}\text{C}$		300	mW
... Derating		3.0	mW/ $^{\circ}\text{C}$
Storage Temperature	-40	+125	$^{\circ}\text{C}$
Operating Temperature	-40	+85	$^{\circ}\text{C}$

D4 Package	Min.	Max.	Units
Total Allowable Power Dissipation at $T_{amb} = 25^{\circ}\text{C}$		800	mW
... Derating		10	mW/ $^{\circ}\text{C}$
Storage Temperature	-40	+125	$^{\circ}\text{C}$
Operating Temperature	-40	+85	$^{\circ}\text{C}$

1.7.1.2 Operating Limits

Correct operation of the device outside these limits is not implied.

	Notes	Min.	Max.	Units
Supply ($V_{DD} - V_{SS}$)		2.7	5.5	V
Operating Temperature		-40	+85	$^{\circ}\text{C}$
Xtal Frequency		0.500	2.048	MHz

CMX639P6 package discontinued

1.7.1.3 Operating Characteristics

For the following conditions unless otherwise specified:

Xtal Frequency = 1.024 MHz, Sample Clock Rate = 32 kbps, Audio Test Frequency = 820 Hz,
 $V_{DD} = 3.0V$ to $5.5V$, $T_{amb} = -40^{\circ}C$ to $+85^{\circ}C$, Audio Level 0dB ref (0dBm0) = 489mV rms.

Static Values	Notes	Min.	Typ.	Max.	Units
I_{DD} (powersaved)	6		600		μA
I_{DD} (enabled) @ $V_{DD} = 3.0V$	6		1.90		mA
I_{DD} (enabled) @ $V_{DD} = 5.0V$	6		2.75		mA
Input Logic '1'		70% V_{DD}			V
Input Logic '0'				30% V_{DD}	V
Output Logic '1'		80% V_{DD}			V
Output Logic '0'				20% V_{DD}	V
Digital Input Impedance					
Logic I/O pins		1.0			$M\Omega$
Logic Input pins, Pull-up Resistor	1	300			$k\Omega$
Digital Output Impedance				4.0	$k\Omega$
Analog Input Impedance	2		100		$k\Omega$
Analog Output Impedance				800	Ω
Three State Output Leakage			± 4		μA
Insertion Loss	3		0		dB

CMX639P6 package discontinued

Dynamic Values	Notes	Min.	Typ.	Max.	Units
Encoder:					
Analog Signal Input Levels					
V _{DD} = 3.0V	7	-37		6	dB
V _{DD} = 5.0V	7	-33		10	dB
Principal Integrator Frequency			160		Hz
Encoder Passband	4		3240		Hz
Comand Time Constant			5		ms
Decoder:					
Analog Signal Output Levels					
V _{DD} = 3.0V	7	-37		6	dB
V _{DD} = 5.0V	7	-33		10	dB
Decoder Passband	4		3200		Hz
Encoder Decoder (Full Codec):					
Passband	4	300		3400	Hz
Stopband		6		10	kHz
Stopband Attenuation			60		dB
Passband Gain			0		dB
Passband Ripple		-3.0		3.0	dB
Output Noise (Input Short Circuit)	8		-60		dBm0p
Perfect Idle Channel Noise (Encode Forced)	8, 9		-63		dBm0p
Group Delay Distortion	5				
(1000Hz - 2600Hz)				450	μs
(600Hz - 2800Hz)				750	μs
(500Hz - 3000Hz)				1500	μs
Xtal/Clock Frequency	10, 11	0.500	1.024	2.048	MHz

Notes:

1. All logic inputs except Encoder and Decoder Data clocks.
2. The source impedance driving the coupling capacitor should be less than 1kΩ. A lower driving source impedance will reduce encoder output channel noise levels.
3. For an Encoder/Decoder combination.
4. See Figure 5.
5. Group Delay Distortion for the full codec is relative to the delay with an 820Hz, -20dB signal at the encoder input.
6. Not including any current drawn from the device pins by external circuits.
7. Recommended values.
8. dBm0p units are measured after the application of a psophometrically weighted filter that is commonly applied in voice communication applications per CCITT Recommendation G.223.
9. Forced idle encode/decode control not available on D4 (16-pin SOIC) package.

CMX639P6 package discontinued

10. Some applications may benefit from the use of an Xtal/Clock frequency other than 1.024MHz.
Note: Codec time constants and filter response curves are effectively proportional to Xtal/Clock frequency and so will shift with the use of Xtal/Clock frequencies other than 1.024MHz. For example, the specified Encoder Decoder (Full Codec) passband of 300Hz min. to 3400Hz max. for a 1.024MHz Xtal/Clock will shift to 600Hz min. to 6800Hz max. when the device is operated from a 2.048MHz Xtal/Clock. For this reason, all CMX639 codecs involved in the same communications link should usually be operated from the same Xtal/Clock frequency.

Example 1: A design saves the cost of a 1.024MHz Xtal or clock generator by making use of an already existing clock source of a frequency other than 1.024MHz.

Example 2: Best noise performance is achieved when the CMX639 codec data clock is internally generated. If a codec bit rate other than 16kbps, 32kbps or 64kbps is desired then an Xtal/Clock different from 1.024MHz can be used to proportionately shift the available set of internally generated clock rates, as needed.

Example 3: To increase the codec high frequency response and audio bandwidth a faster Xtal/Clock speed can be used. Other designs may prefer the proportionately higher codec bandwidths and data rates that can be supported with faster clock speeds.

11. In general, optimum codec performance is achieved when both encoder and decoder Xtal/Clock signals are synchronized. While this is practical in many telecom applications, it may not be so for others such as wireless data links. The CMX639 decoder can generally deliver best performance when its data clock is recovered/derived from the received data stream and applied as an external data clock to the decoder as per the decoder timing depicted in Figure 4. Nonetheless, some Xtal/Clock frequency and data rate combinations are better served by the use of internal clocks. Experimentation with each specific design may provide the best guidance for making this design choice.

CMX639P6 package discontinued

1.7.1.3 Operating Characteristics (continued)

Timing Diagram

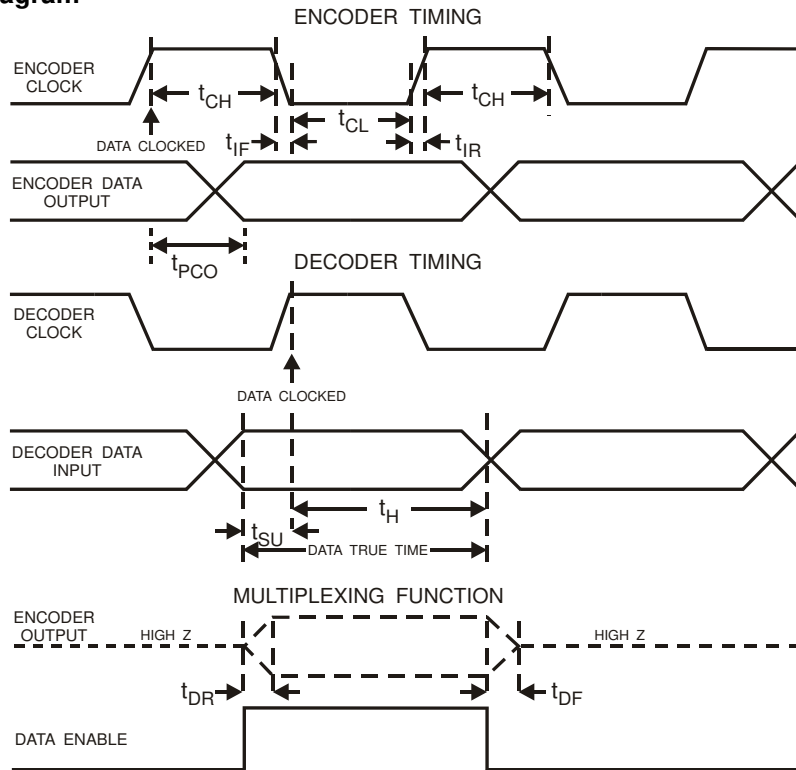

Figure 4 Serial Bus Timing

For the following conditions unless otherwise specified:

Xtal Frequency = 1.024 MHz, V_{DD} = 3.0V to 5.0V, T_{amb} = - 40°C to +85°C.

Serial Bus Timing (ref. Figure 4)	Notes	Min.	Typ.	Max.	Units
t_{CH}	Clock 1 pulse width	1.0			μ s
t_{CL}	Clock 0 pulse width	1.0			μ s
t_{IR}	Clock rise time	0	100		ns
t_{IF}	Clock fall time		100		ns
t_{SU}	Data set-up time			450	ns
t_H	Data hold time	600			ns
$t_{SU} + t_H$	Data true time		1.5		μ s
t_{PCO}	Clock to output delay time		750		ns
t_{DR}	Data rise time		100		ns
t_{DF}	Data fall time		100		ns

CMX639P6 package discontinued

1.7.1.3 Operating Characteristics (continued)

Typical Codec Performance

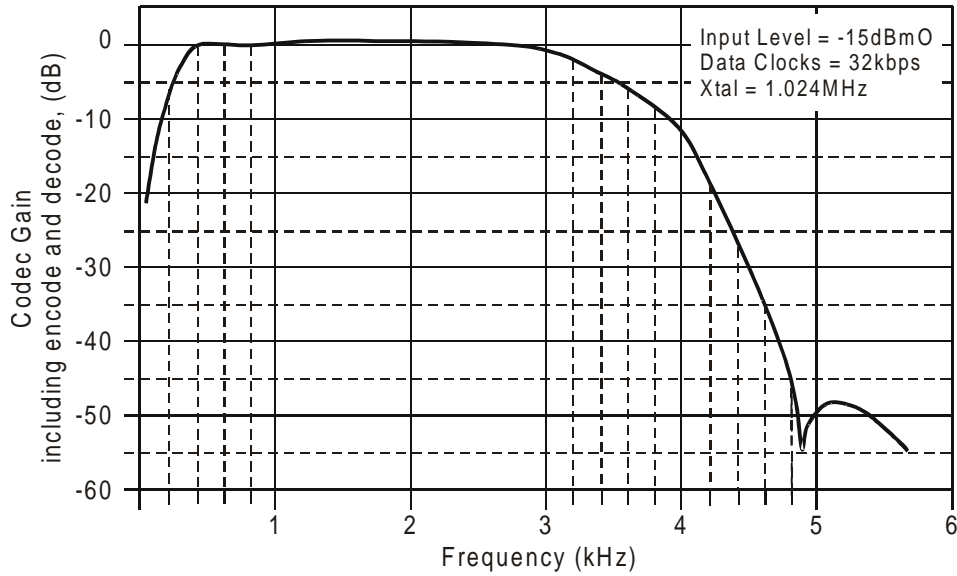

Figure 5 Typical Frequency Response (32kbps)

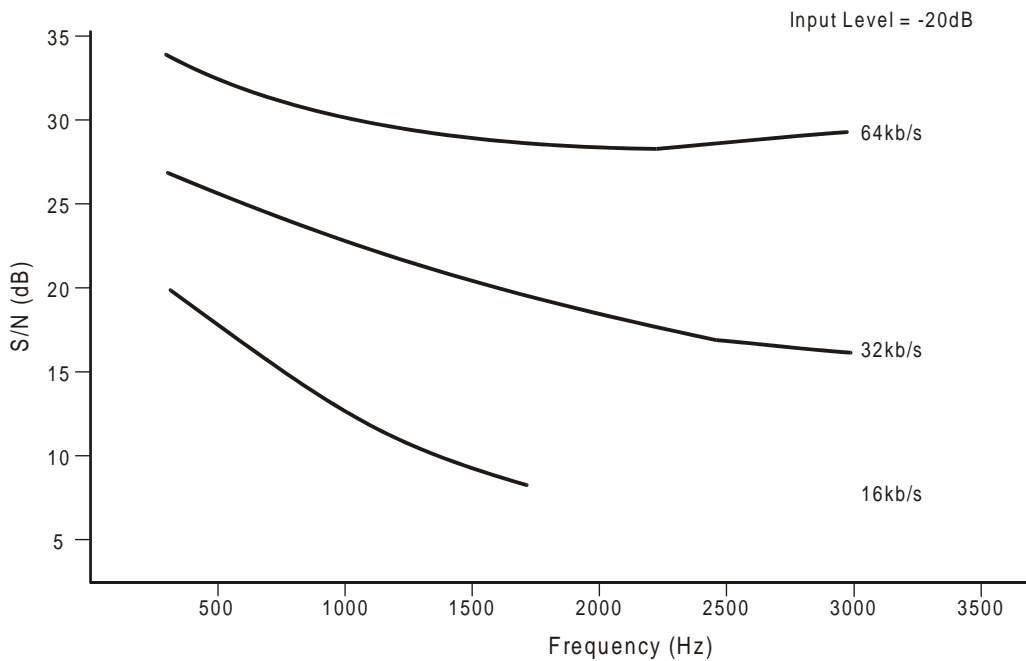

Figure 6 Typical S/N Ratio with Input Frequency

CMX639P6 package discontinued

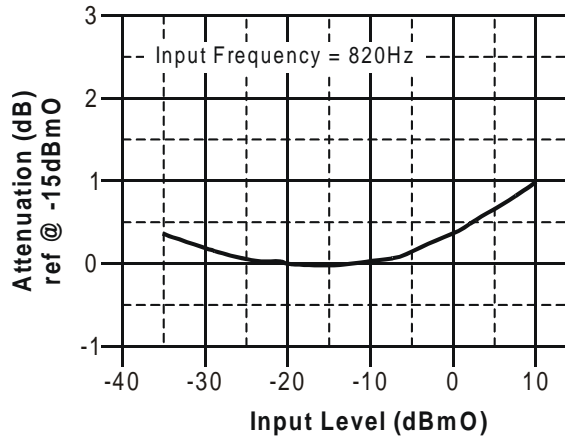

Figure 7 Typical Variation of Gain with Input Level (32kbps)

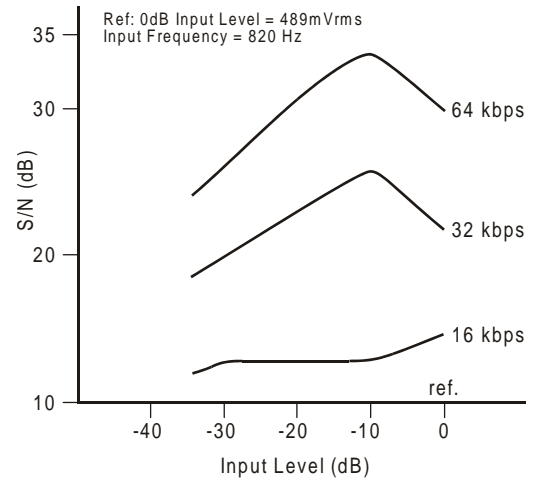

Figure 8 Typical S/N Ratio with Input Level

CMX639P6 package discontinued

1.7.2 Packaging

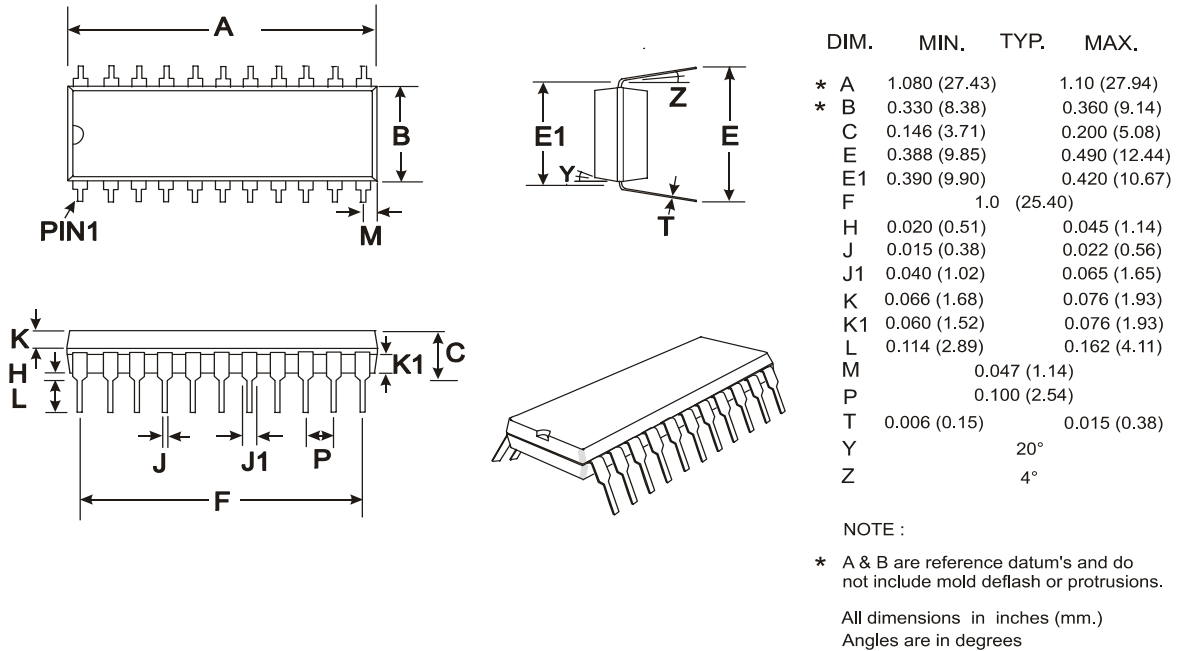

Figure 9 P6 Mechanical Outline: Order as part no. **CMX639P6**

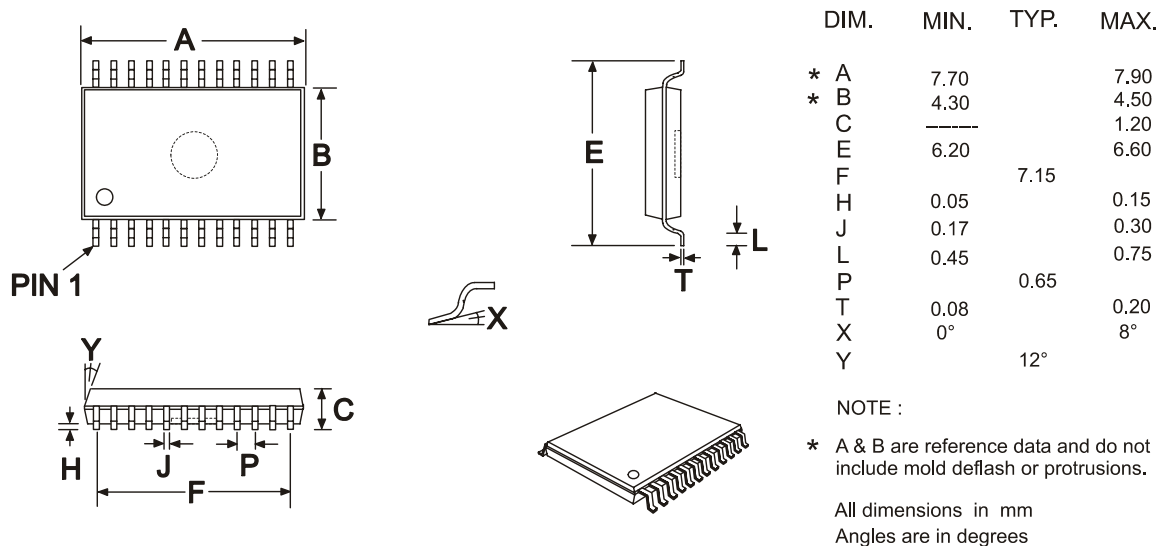
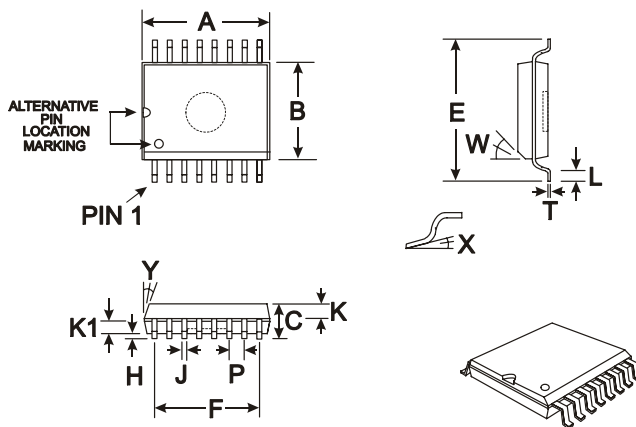

Figure 10 E2 Mechanical Outline: Order as part no. **CMX639E2**

CMX639P6 package discontinued



DIM.	MIN.	TYP.	MAX.
* A	0.395 (10.03)	0.413 (10.49)	
* B	0.286 (7.26)	0.299 (7.59)	
C	0.088 (2.24)	0.105 (2.67)	
E	0.390 (9.90)	0.419 (10.64)	
F		0.350 (8.89)	
H	0.003 (0.08)	0.020 (0.51)	
J	0.013 (0.33)	0.020 (0.51)	
K		0.041 (1.04)	
K1		0.041 (1.04)	
L	0.016 (0.41)	0.050 (1.27)	
P		0.050 (1.27)	
T	0.009 (0.23)	0.0125 (0.32)	
W		45°	
X	0°		10°
Y		7°	

NOTE :

* A & B are reference datum's and do not include mold deflash or protrusions.

All dimensions in inches (mm.)

Angles are in degrees

Co-Planarity of leads within 0.004" (0.1mm)

Figure 11 D4 Mechanical Outline: Order as part no. **CMX639D4**

Handling precautions: This product includes input protection, however, precautions should be taken to prevent device damage from electro-static discharge. CML does not assume any responsibility for the use of any circuitry described. No IPR or circuit patent licences are implied. CML reserves the right at any time without notice to change the said circuitry and this product specification. CML has a policy of testing every product shipped using calibrated test equipment to ensure compliance with this product specification. Specific testing of all circuit parameters is not necessarily performed.

www.cmlmicro.com

 <p>CML Microcircuits (UK) Ltd COMMUNICATION SEMICONDUCTORS</p>	 <p>CML Microcircuits (USA) Inc. COMMUNICATION SEMICONDUCTORS</p>	 <p>CML Microcircuits (Singapore) Pte Ltd COMMUNICATION SEMICONDUCTORS</p>	
<p>Oval Park, Langford, Maldon, Essex, CM9 6WG - England.</p> <p>Tel: +44 (0)1621 875500 Fax: +44 (0)1621 875600</p> <p>Sales: sales@cmlmicro.com</p> <p>Technical Support: techsupport@cmlmicro.com</p>	<p>4800 Bethania Station Road, Winston-Salem, NC 27105 - USA.</p> <p>Tel: +1 336 744 5050, 800 638 5577 Fax: +1 336 744 5054</p> <p>Sales: us.sales@cmlmicro.com</p> <p>Technical Support: us.techsupport@cmlmicro.com</p>	<p>No 2 Kallang Pudding Road, #09 - 05/06 Mactech Industrial Building, Singapore 349307</p> <p>Tel: +65 6745 0426 Fax: +65 6745 2917</p> <p>Sales: sg.sales@cmlmicro.com</p> <p>Technical Support: sg.techsupport@cmlmicro.com</p>	<p>No. 218, Tian Mu Road West, Tower 1, Unit 1008, Shanghai Kerry Everbright City, Zhabei, Shanghai 200070, China.</p> <p>Tel: +86 21 6317 4107 +86 21 6317 8916 Fax: +86 21 6317 0243</p> <p>Sales: cn.sales@cmlmicro.com.cn</p> <p>Technical Support: sg.techsupport@cmlmicro.com</p>