

THIS DRAWING IS UNPUBLISHED. RELEASED FOR PUBLICATION .19
 BY AMP INCORPORATED. ALL RIGHTS RESERVED.

LOC	DIST	REVISIONS					
CM	00	P	LTR	DESCRIPTION	DATE	DWN	APVD
		A		RELEASED PER EC 063B-0318-00	23-JUNE-00	KW	SR

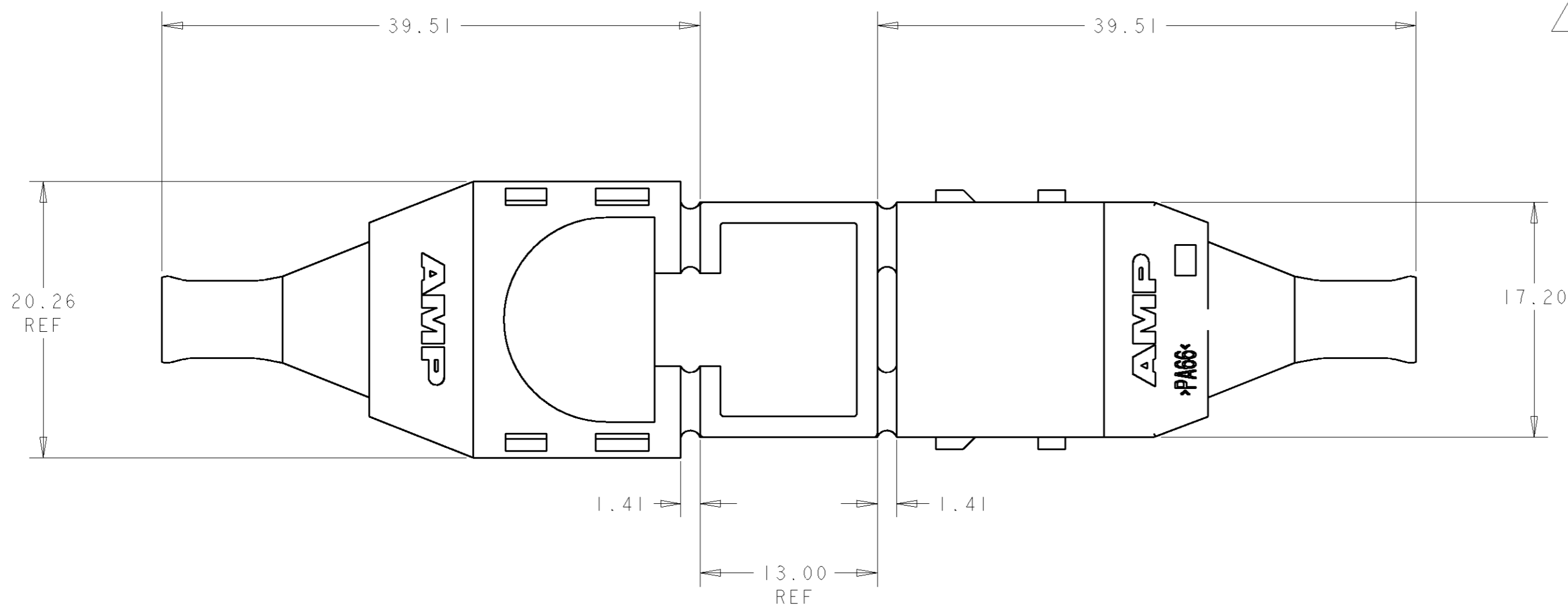

NYLON, UL94V-2, COLOR; NATURAL.

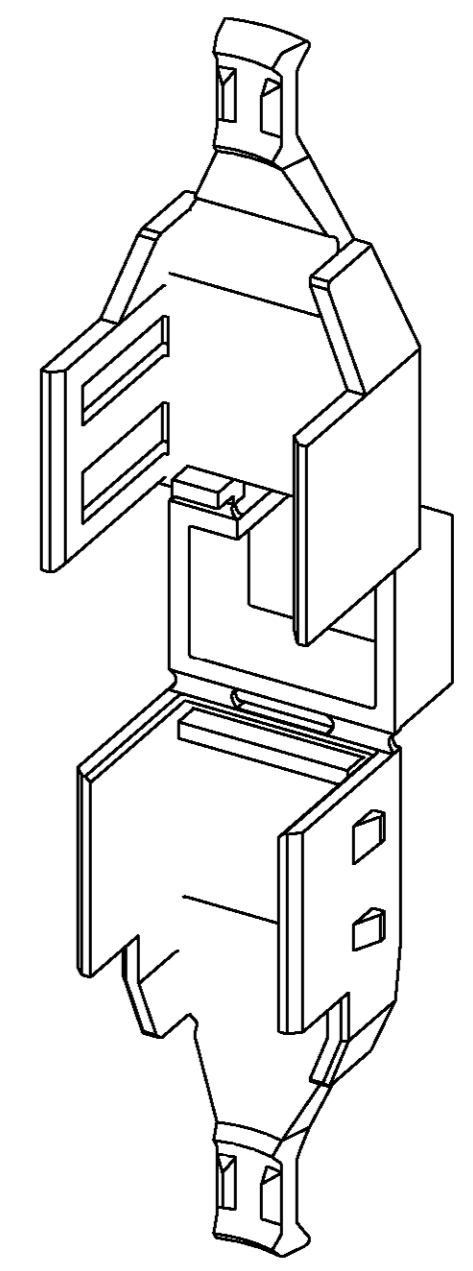

SCALE 2:1

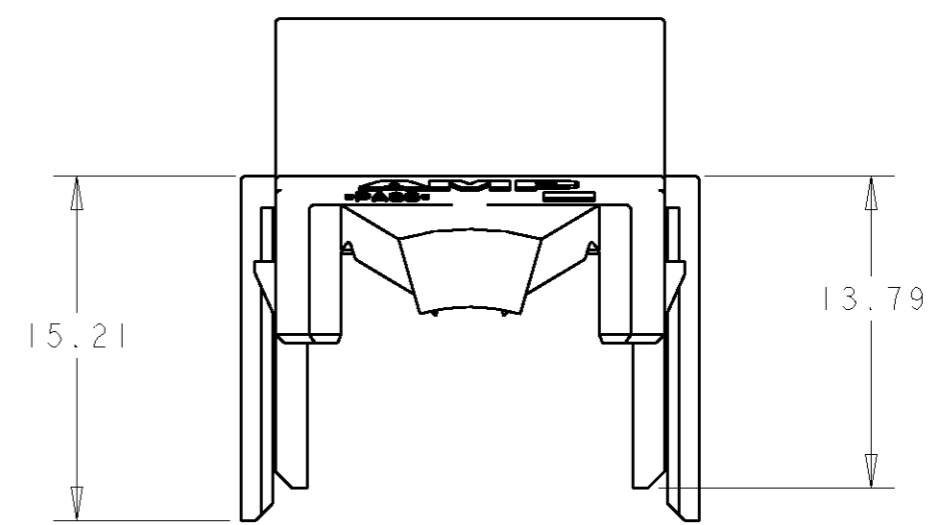
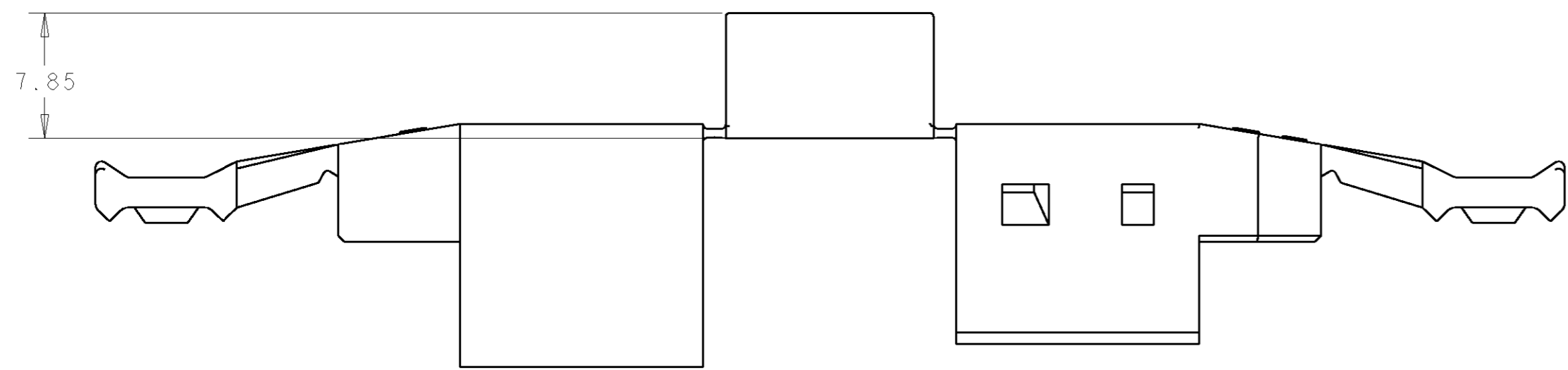

1375618-1
PART NUMBER

THIS DRAWING IS A CONTROLLED DOCUMENT FOR AMP INCORPORATED. IT IS SUBJECT TO CHANGE AND THE CONTROLLING ENGINEERING ORGANIZATION SHOULD BE CONTACTED FOR THE LATEST REVISION.		DWN K. KOEGEL 15FEB100 CHK W. DAVIS 15FEB100 APVD S. RIDGILL 22-MAY-2000	AMP AMP Incorporated Harrisburg, PA 17105-3608
DIMENSIONS: mm	TOLERANCES UNLESS OTHERWISE SPECIFIED: 0 PLC ± 1 PLC ± 2 PLC ±0.13 3 PLC ± 4 PLC ± ANGLES ± FINISH -	PRODUCT SPEC - APPLICATION SPEC - WEIGHT -	NAME DUAC STRAIN RELIEF, 6 POSITION SIZE A2 CAGE CODE 00779 DRAWING NO. C-1375618 RESTRICTED TO - SCALE 3:1 SHEET 1 OF 1 REV A
MATERIAL -		CUSTOMER DRAWING	

METRIC