

Pb THIS PRODUCT MANUFACTURED WITH LEAD-FREE PROCESSING

DESIGNED & DIMENSIONED IN MILLIMETERS [INCHES]

DCH-XX-XX.X-X-XX-X-X-X

DO NOT SCALE FROM THIS PRINT

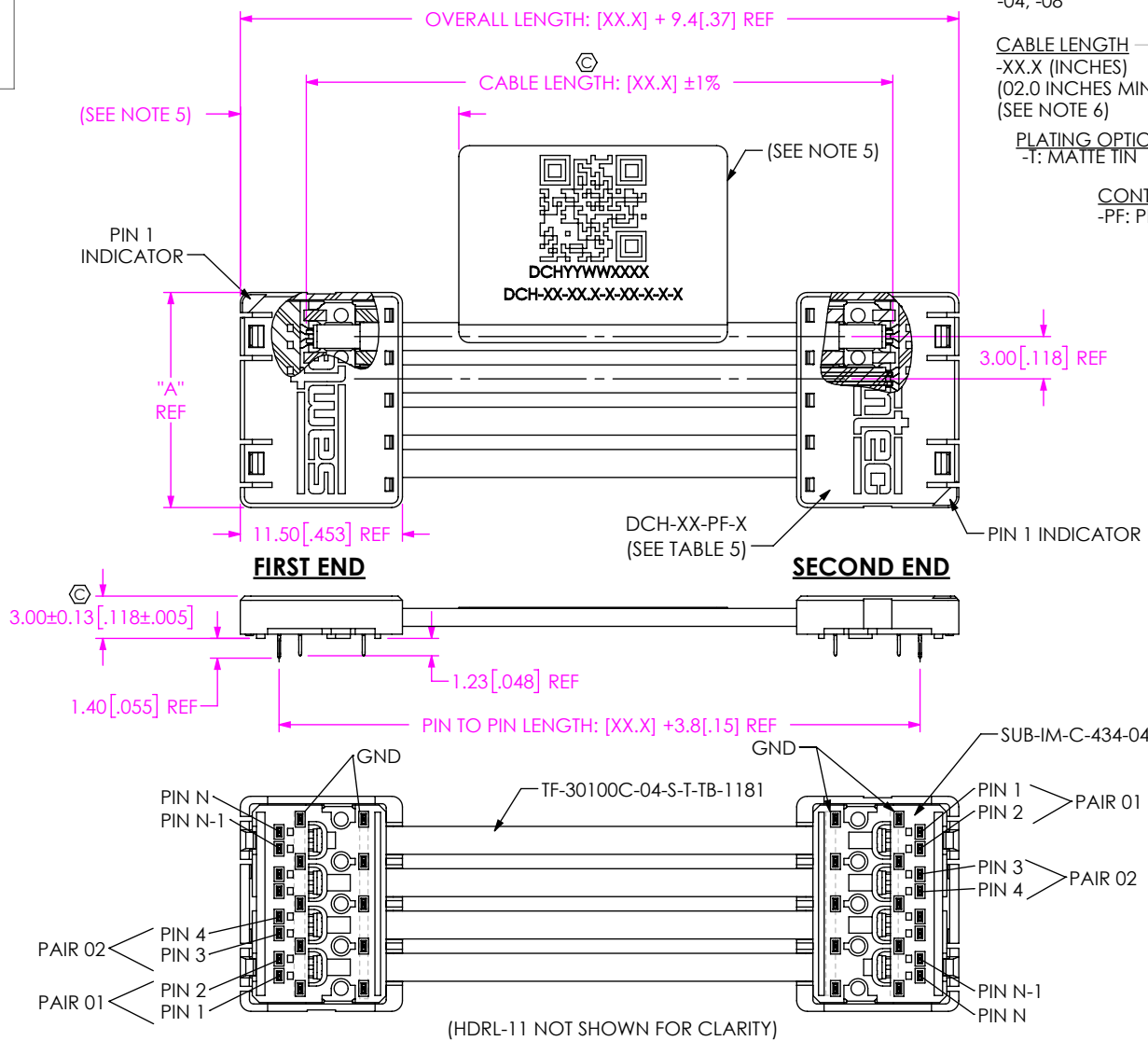

No OF PAIRS
-04, -08

CABLE LENGTH
-XX.X (INCHES)
(02.0 INCHES MINIMUM)
(SEE NOTE 6)

PLATING OPTION
-T: MATTE TIN

CONTACT STYLE
-PF: PRESS FIT

OPTION
-S: STRAIGHT STRAIN RELIEF
-T: THIRTY DEGREE ANGLED STRAIN RELIEF
(LEAVE BLANK FOR NO STRAIN RELIEF, AVAILABLE TO EXISTING CUSTOMERS ONLY)

WIRING OPTION
-1: PIN 1 TO PIN 1
(SEE SHT 2, FIG 3 & SHT 5, TABLE 2)
-4: PIN 1 TO PIN N
(SEE FIG 1 & 2, & SHT 5, TABLE 3)

SECOND END OPTION
-1: DCH

(* = NOT RELEASED FOR PRODUCTION)

PAIRS	"A"	N	N-1
-04	15.25 [.600]	8	7
-08	30.25 [1.191]	16	15

OPTION	PAIRS	
	-04	-08
-(BLANK)	DCH-04-PF-C	DCH-08-PF-C
-S, -T	DCH-04-PF-S	DCH-08-PF-S

FIG 1
DCH-04-XX.X-X-PF-1-4 SHOWN

- NOTES:
1. REPRESENTS A CRITICAL DIMENSION.
 2. ALL ASSEMBLIES TO BE 100% HI-POT TESTED AT 300V.
 3. ALL ASSEMBLIES TO BE 100% ELECTRICALLY TESTED FOR SHORTS AND OPENS.
 4. FOR PACKAGING REQUIREMENTS REFERENCE PACKAGING STANDARDS.
 5. HDRL-11 TO BE CENTERED ON CABLE AS SHOWN. LABEL TO CONTAIN:
LINE 1 - QR CODE "DCH-XX-XX.X-X-XX-X-X-X"
LINE 2 - SERIAL NUMBER "DCHYYWXXXX".
LINE 3 - PART NUMBER "DCH-XX-XX.X-X-XX-X-X-X".
 6. CABLE LENGTHS LONGER THAN 40.00 INCHES ARE NOT SUPPORTED BY S.I. TEST DATA.
 7. MOLDED SURFACES SHALL BE CONSISTENT AND SMOOTH. SURFACES TO BE FREE OF SCRATCHES, NICKS, SINK AREAS, VOIDS OR OTHER BLEMISHES.
 8. REFER TO PREP-SPEC.PDF FOR CABLE PREP DIMENSIONS.
ASSEMBLY USES PREP-SPEC-020-010-120 PREP.

UNLESS OTHERWISE SPECIFIED, DIMENSIONS ARE IN MILLIMETERS.

TOLERANCES ARE:

DECIMALS	ANGLES
X.X: ±0.3 [.01]	2°
X.XX: ±0.13 [.005]	
X.XXX: ±0.051 [.0020]	

PROPRIETARY NOTE

THIS DOCUMENT CONTAINS CONFIDENTIAL AND PROPRIETARY INFORMATION AND ALL DESIGN, MANUFACTURING, REPRODUCTION, USE, PATENT RIGHTS AND SALES RIGHTS ARE EXPRESSLY RESERVED BY SAMTEC, INC. THIS DOCUMENT SHALL NOT BE DISCLOSED, IN WHOLE OR PART, TO ANY UNAUTHORIZED PERSON OR ENTITY NOR REPRODUCED, TRANSFERRED OR INCORPORATED IN ANY OTHER PROJECT IN ANY MANNER WITHOUT THE EXPRESS WRITTEN CONSENT OF SAMTEC, INC.

MATERIAL: DO NOT SCALE DRAWING SHEET SCALE: 2:1

INSULATOR: LCP
TERMINAL: COPPER ALLOY
CABLE INSULATION: THV
DIELECTRIC: FEP
WIRE: SILVER PLATED COPPER
CAP: PBT

F:\DWG\MISC\MKTG\DCH-XX-XX.X-X-XX-X-X-MKT.SLDDRW

520 PARK EAST BLVD, NEW ALBANY, IN 47150
PHONE: 812-944-6733 FAX: 812-948-5047
e-Mail: info@SAMTEC.com code 53322

DESCRIPTION:
DIRECT CONNECT HIGH SPEED CABLE ASM

DWG. NO.
DCH-XX-XX.X-X-XX-X-X-X

BY: D.SCHMELZ 3/21/2016 SHEET 1 OF 6

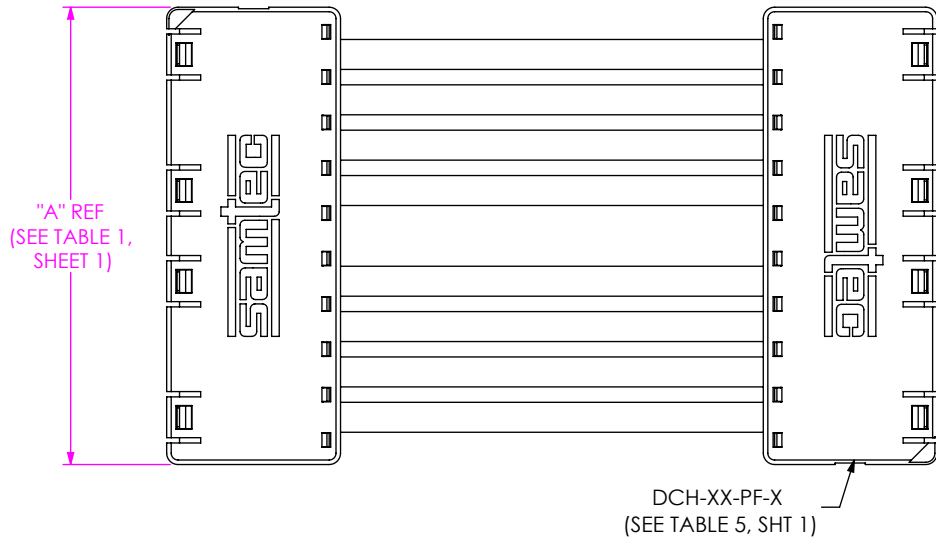

FIRST END

SECOND END

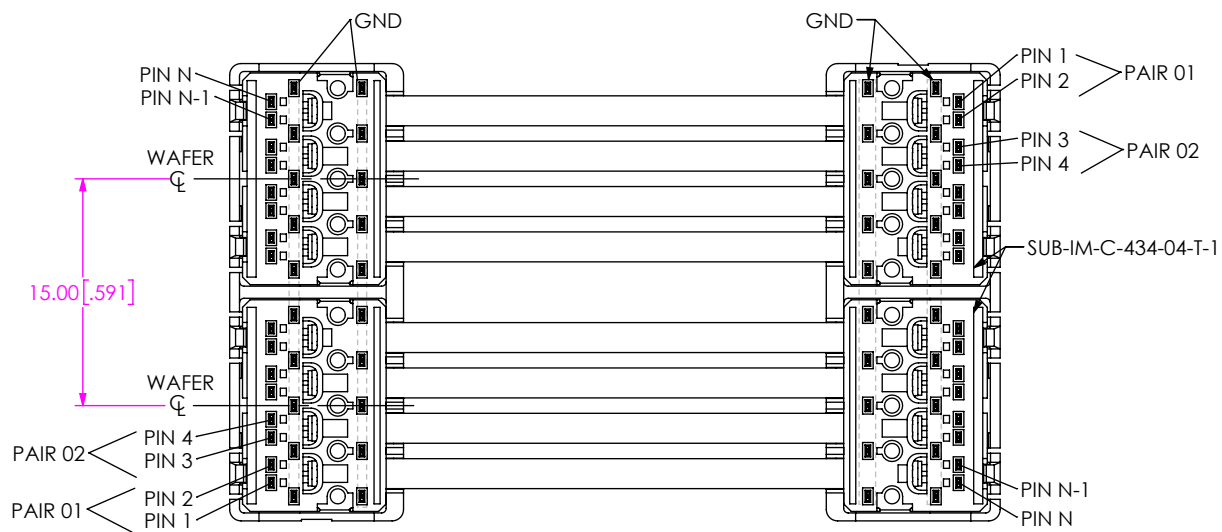
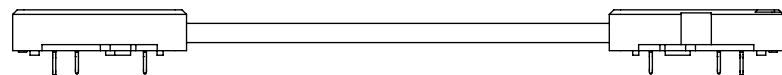
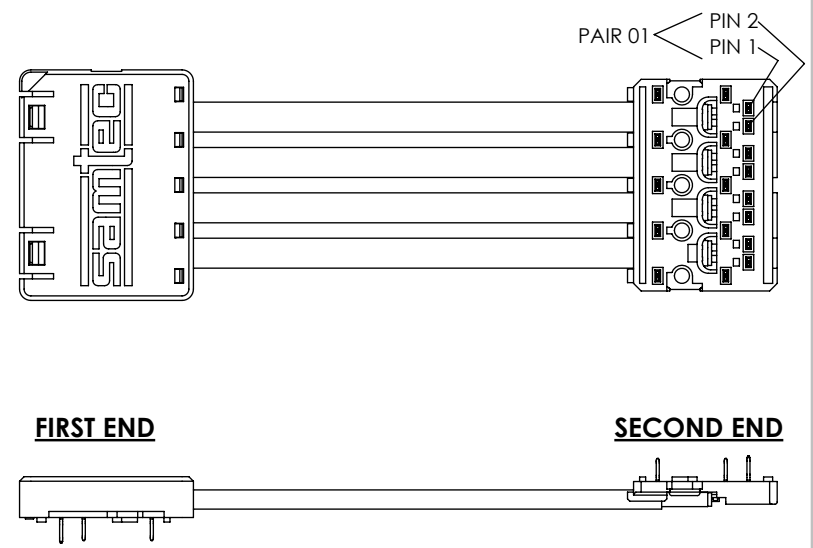

FIG 2

DCH-08-XX.X-X-PF-1-4 SHOWN
(DIFFERENT AS SHOWN, OTHERWISE SAME AS FIG 1)



FIRST END

SECOND END

FIG 3

DCH-04-XX.X-X-PF-1-1 SHOWN
(DIFFERENT AS SHOWN, OTHERWISE SAME AS FIG 1)

PROPRIETARY NOTE
THIS DOCUMENT CONTAINS CONFIDENTIAL AND PROPRIETARY INFORMATION AND ALL DESIGN, MANUFACTURING, REPRODUCTION, USE, PATENT RIGHTS AND SALES RIGHTS ARE EXPRESSLY RESERVED BY SAMTEC, INC. THIS DOCUMENT SHALL NOT BE DISCLOSED, IN WHOLE OR PART, TO ANY UNAUTHORIZED PERSON OR ENTITY NOR REPRODUCED, TRANSFERRED OR INCORPORATED IN ANY OTHER PROJECT IN ANY MANNER WITHOUT THE EXPRESS WRITTEN CONSENT OF SAMTEC, INC.



520 PARK EAST BLVD, NEW ALBANY, IN 47150
PHONE: 812-944-6733 FAX: 812-948-5047
e-Mail info@SAMTEC.com code 55322

DO NOT SCALE DRAWING

SHEET SCALE: 2:1

DESCRIPTION:
DIRECT CONNECT HIGH SPEED CABLE ASM
DWG. NO.

DCH-XX-XX.X-X-XX-X-X-X

BY: D.SCHMELZ 3/21/2016 SHEET 2 OF 6

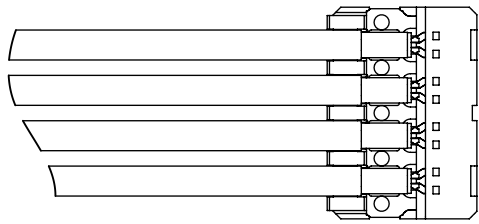

IN-PROCESS TERMINATE CABLE
(SEE SHEET 6 FOR TERMINATION DETAILS)

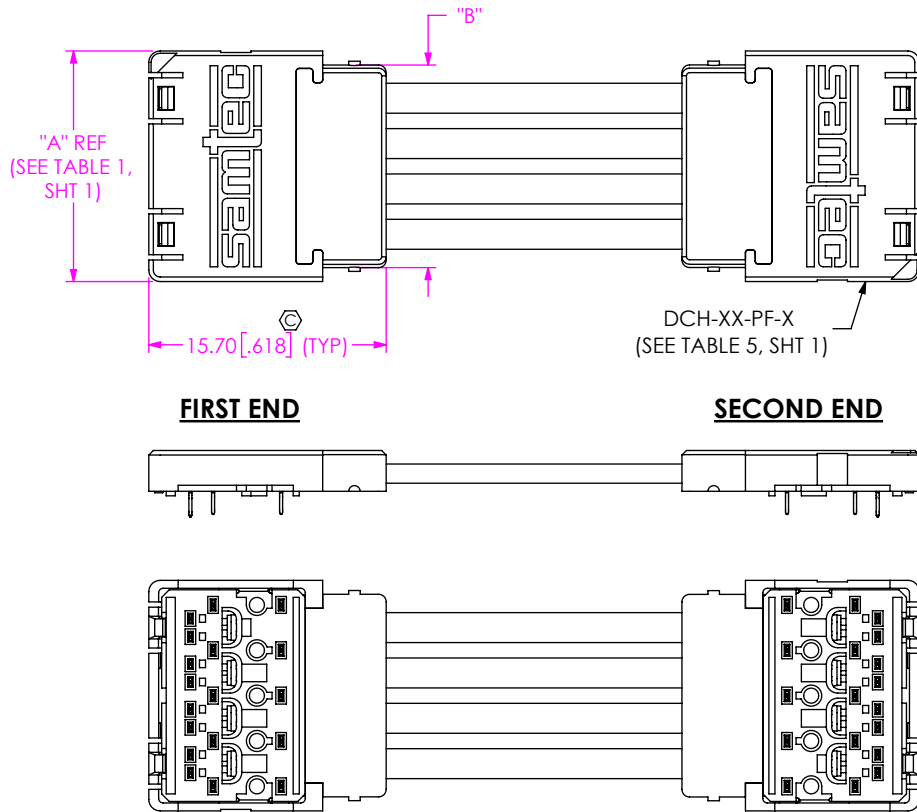

FIG 4
DCH-04-XX.X-X-PF-1-4-S SHOWN
(DIFFERENT AS SHOWN, OTHERWISE SAME AS FIG 1)

TABLE 4	
PAIRS	"B"
-04	13.40 [.528]
-08	28.40 [1.118]

F:\DWG\MISC\MKTG\DCH-XX-XX.X-X-XX-X-X-MKT.SLDDRW

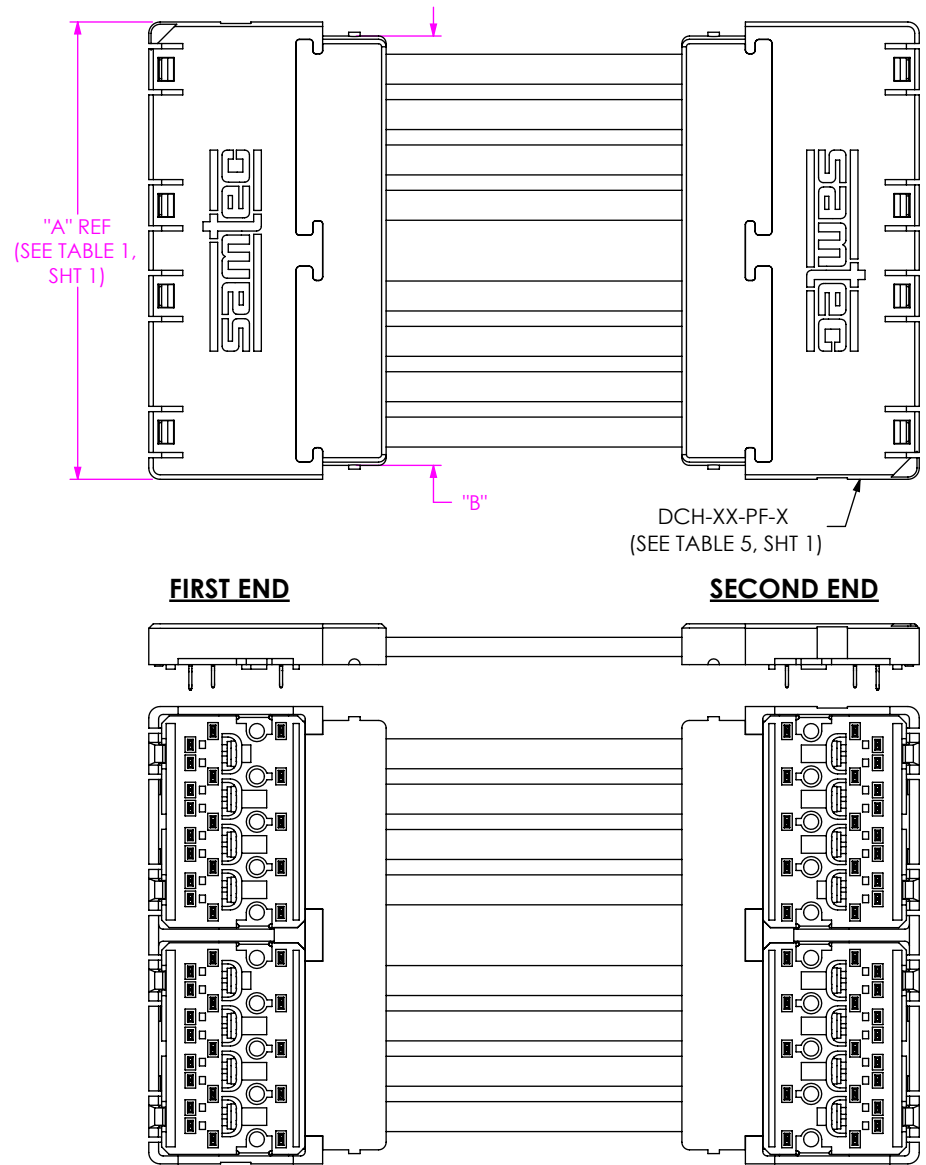

FIG 5
DCH-08-XX.X-X-PF-1-4-S SHOWN
(DIFFERENT AS SHOWN, OTHERWISE SAME AS FIG 2 & 4)

PROPRIETARY NOTE
THIS DOCUMENT CONTAINS CONFIDENTIAL AND PROPRIETARY INFORMATION AND ALL DESIGN, MANUFACTURING, REPRODUCTION, USE, PATENT RIGHTS AND SALES RIGHTS ARE EXPRESSLY RESERVED BY SAMTEC, INC. THIS DOCUMENT SHALL NOT BE DISCLOSED, IN WHOLE OR PART, TO ANY UNAUTHORIZED PERSON OR ENTITY NOR REPRODUCED, TRANSFERRED OR INCORPORATED IN ANY OTHER PROJECT IN ANY MANNER WITHOUT THE EXPRESS WRITTEN CONSENT OF SAMTEC, INC.

DO NOT SCALE DRAWING

SHEET SCALE: 2:1



520 PARK EAST BLVD, NEW ALBANY, IN 47150
PHONE: 812-944-6733 FAX: 812-948-5047
e-Mail info@SAMTEC.com code 55322

DESCRIPTION:
DIRECT CONNECT HIGH SPEED CABLE ASM

DWG. NO.
DCH-XX-XX.X-X-XX-X-X-X

BY: D.SCHMELZ 3/21/2016 SHEET 3 OF 6

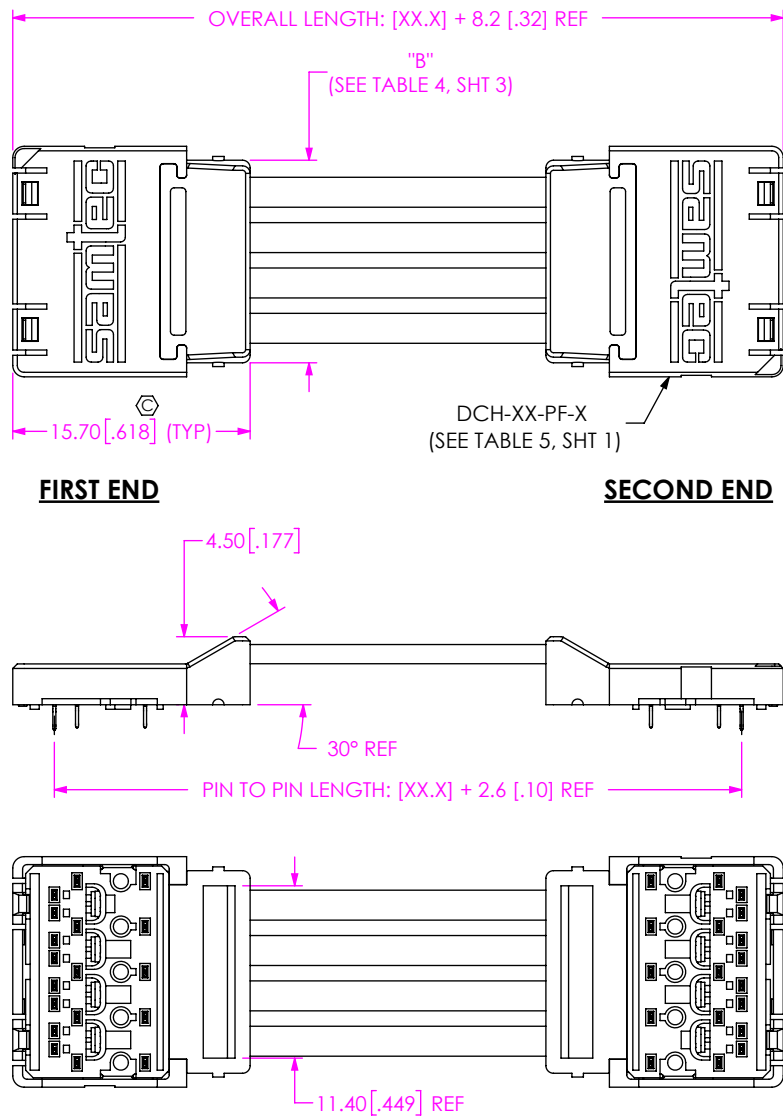

FIG 6
DCH-04-XX.X-X-PF-1-4-T SHOWN
(DIFFERENT AS SHOWN, OTHERWISE SAME AS FIG 1)

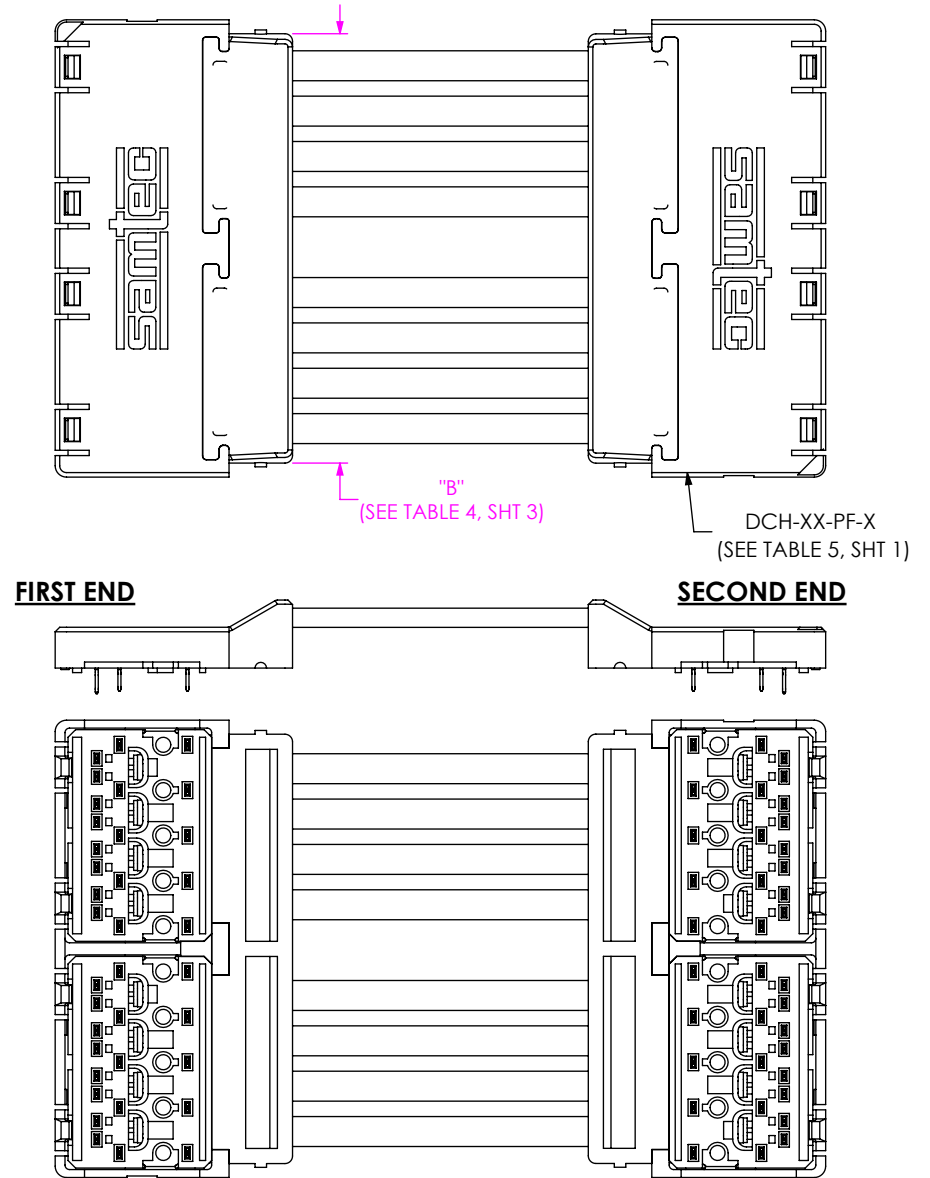

FIG 7
DCH-08-XX.X-X-PF-1-4-T SHOWN
(DIFFERENT AS SHOWN, OTHERWISE SAME AS FIG 2 & 6)

PROPRIETARY NOTE
THIS DOCUMENT CONTAINS CONFIDENTIAL AND PROPRIETARY INFORMATION AND ALL DESIGN, MANUFACTURING, REPRODUCTION, USE, PATENT RIGHTS AND SALES RIGHTS ARE EXPRESSLY RESERVED BY SAMTEC, INC. THIS DOCUMENT SHALL NOT BE DISCLOSED, IN WHOLE OR PART, TO ANY UNAUTHORIZED PERSON OR ENTITY NOR REPRODUCED, TRANSFERRED OR INCORPORATED IN ANY OTHER PROJECT IN ANY MANNER WITHOUT THE EXPRESS WRITTEN CONSENT OF SAMTEC, INC.



520 PARK EAST BLVD, NEW ALBANY, IN 47150
PHONE: 812-944-6733 FAX: 812-948-5047
e-Mail info@SAMTEC.com code 55322

DO NOT SCALE DRAWING

SHEET SCALE: 2:1

DESCRIPTION:
DIRECT CONNECT HIGH SPEED CABLE ASM

DWG. NO.
DCH-XX-XX.X-X-XX-X-X-X

BY: D.SCHMELZ 3/21/2016 SHEET 4 OF 6

TABLE 2 (SECOND END OPTION -1; WIRING OPTION -1)

NO OF PAIRS		SIGNAL MAPPING																	
-04	FIRST END	1	2	3	4	5	6	7	8	NUMBER OF GND PINS: 10									
	SECOND END	PAIR		PAIR		PAIR		PAIR											
-08	FIRST END	1	2	3	4	5	6	7	8	9	10	11	12	13	14	15	16	NUMBER OF GND PINS: 20	
	SECOND END	PAIR		PAIR		PAIR		PAIR		PAIR		PAIR		PAIR		PAIR			
		1	2	3	4	5	6	7	8	9	10	11	12	13	14	15	16		
ALL GROUNDS ARE COMMON AND TIED TO CABLE SHIELD																			

TABLE 3 (SECOND END OPTION -1; WIRING OPTION -4)

NO OF PAIRS		SIGNAL MAPPING																	
-04	FIRST END	1	2	3	4	5	6	7	8	NUMBER OF GND PINS: 10									
	SECOND END	PAIR		PAIR		PAIR		PAIR											
-08	FIRST END	1	2	3	4	5	6	7	8	9	10	11	12	13	14	15	16	NUMBER OF GND PINS: 20	
	SECOND END	PAIR		PAIR		PAIR		PAIR		PAIR		PAIR		PAIR		PAIR			
		8	7	6	5	4	3	2	1										
		16	15	14	13	12	11	10	9	8	7	6	5	4	3	2	1		
ALL GROUNDS ARE COMMON AND TIED TO CABLE SHIELD																			

PACKAGING VIEW

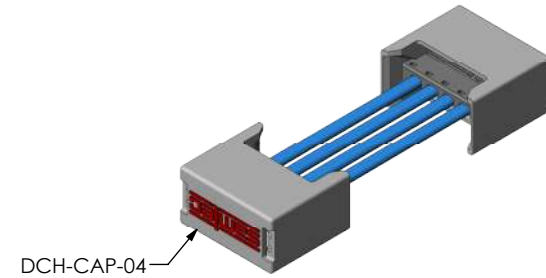

DCH-CAP-04

-04 PAIRS

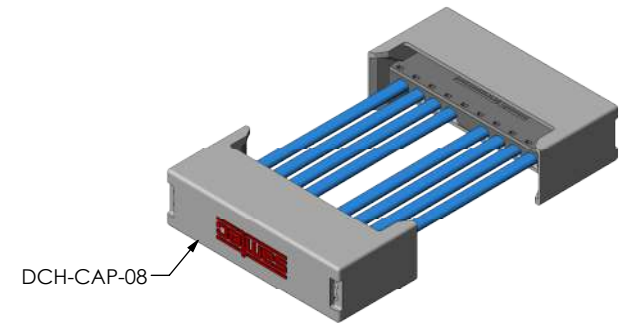

DCH-CAP-08

-08 PAIRS

PROPRIETARY NOTE
 THIS DOCUMENT CONTAINS CONFIDENTIAL AND PROPRIETARY INFORMATION AND ALL DESIGN, MANUFACTURING, REPRODUCTION, USE, PATENT RIGHTS AND SALES RIGHTS ARE EXPRESSLY RESERVED BY SAMTEC, INC. THIS DOCUMENT SHALL NOT BE DISCLOSED, IN WHOLE OR PART, TO ANY UNAUTHORIZED PERSON OR ENTITY NOR REPRODUCED, TRANSFERRED OR INCORPORATED IN ANY OTHER PROJECT IN ANY MANNER WITHOUT THE EXPRESS WRITTEN CONSENT OF SAMTEC, INC.

samtec
 520 PARK EAST BLVD, NEW ALBANY, IN 47150
 PHONE: 812-944-6733 FAX: 812-948-5047
 e-Mail: info@SAMTEC.com code 55322

DO NOT SCALE DRAWING

SHEET SCALE: 2:1

DESCRIPTION:
 DIRECT CONNECT HIGH SPEED CABLE ASM

DWG. NO.
DCH-XX-XX.X-X-XX-X-X-X

BY: D.SCHMELZ 3/21/2016 SHEET 5 OF 6

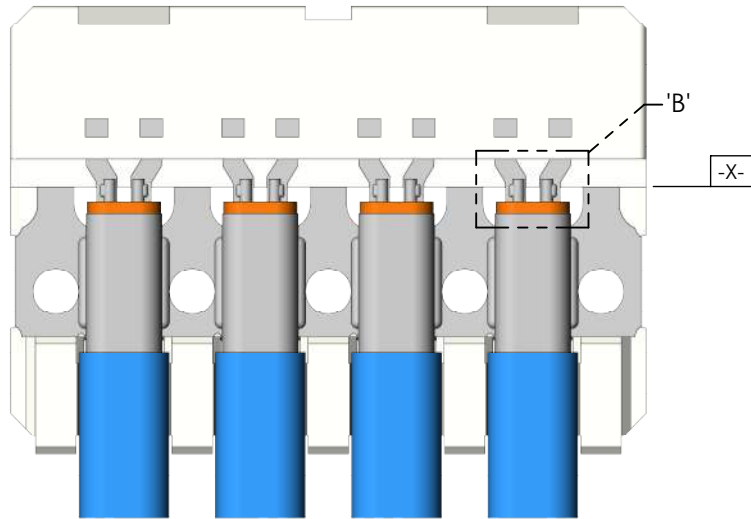

HATBAR IC
ALIGNMENT VIEW

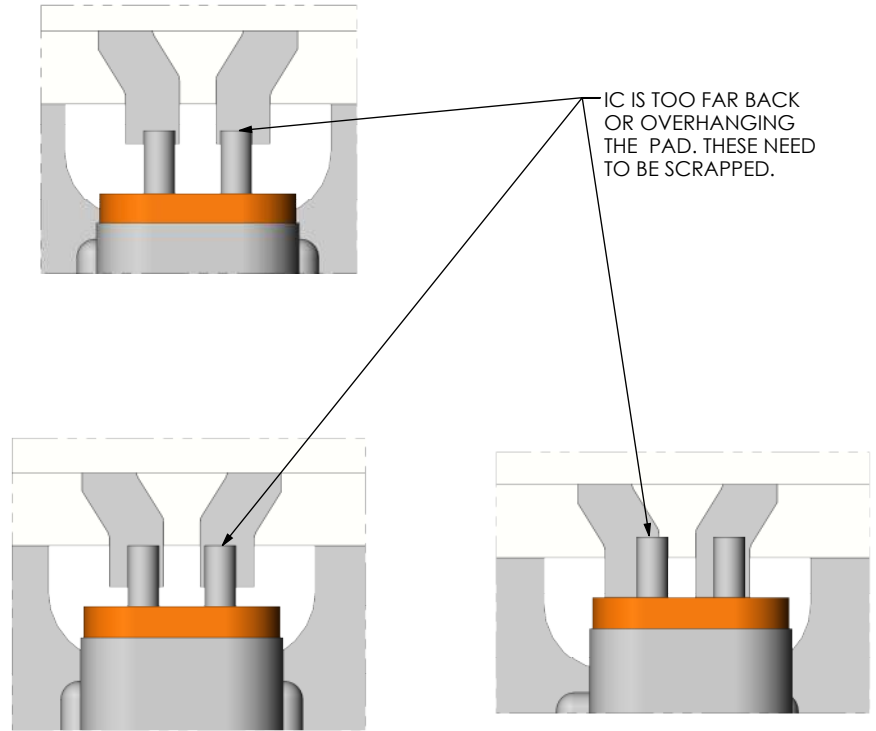

IC IS TOO FAR BACK OR OVERHANGING THE PAD. THESE NEED TO BE SCRAPPED.

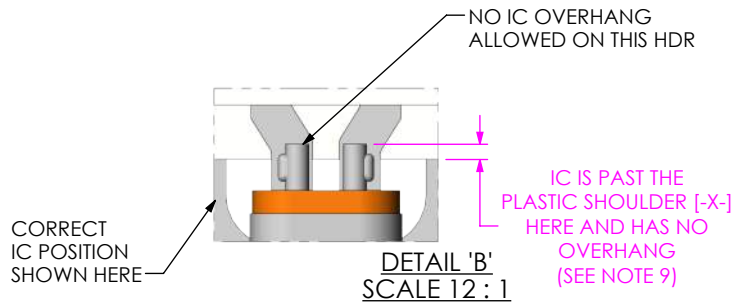

NO IC OVERHANG ALLOWED ON THIS HDR

CORRECT IC POSITION SHOWN HERE

DETAIL 'B'
SCALE 12 : 1

IC IS PAST THE PLASTIC SHOULDER [-X-] HERE AND HAS NO OVERHANG (SEE NOTE 9)

PROPRIETARY NOTE
THIS DOCUMENT CONTAINS CONFIDENTIAL AND PROPRIETARY INFORMATION AND ALL DESIGN, MANUFACTURING, REPRODUCTION, USE, PATENT RIGHTS AND SALES RIGHTS ARE EXPRESSLY RESERVED BY SAMTEC, INC. THIS DOCUMENT SHALL NOT BE DISCLOSED, IN WHOLE OR PART, TO ANY UNAUTHORIZED PERSON OR ENTITY NOR REPRODUCED, TRANSFERRED OR INCORPORATED IN ANY OTHER PROJECT IN ANY MANNER WITHOUT THE EXPRESS WRITTEN CONSENT OF SAMTEC, INC.



520 PARK EAST BLVD, NEW ALBANY, IN 47150
PHONE: 812-944-6733 FAX: 812-948-5047
e-Mail info@SAMTEC.com code 55322

DO NOT SCALE DRAWING

SHEET SCALE: 1:1

DESCRIPTION:
DIRECT CONNECT HIGH SPEED CABLE ASM

DWG. NO.
DCH-XX-XX.X-X-XX-X-X-X

BY: D.SCHMELZ 3/21/2016 SHEET 6 OF 6