

# TYPES SN54LS354, SN54LS355, SN54LS356, SN54LS357, SN74LS354, SN74LS355, SN74LS356, SN74LS357 8-LINE TO 1-LINE DATA SELECTORS/MULTIPLEXERS/REGISTERS

D 2544, JULY 1979—REVISED APRIL 1985

- **Transparent Latches on Data Select Inputs**
- **Choice of Data Registers:**  
Transparent ('LS354, 'LS355)  
Edge-Triggered ('LS356, 'LS357)
- **Choice of Outputs:**  
Three-State ('LS354, 'LS356)  
Open-Collector ('LS355, 'LS357)
- **Complementary Outputs**
- **Easily Expandable**
- **High-Density 20-Pin Package**

## description

These monolithic data selectors/multiplexers contain full on-chip binary decoding to select one of eight data sources. The data-select address is stored in transparent latches that are enabled by a low level on pin 11, SC. On the 'LS354 and 'LS355 a similar enable for data is obtained by a low level on pin 9, DC. The edge-triggered data registers of the 'LS356 and 'LS357 are clocked by a low-to-high transition on pin 9, CLK. Complementary outputs are available in either three-state versions ('LS354 and 'LS356) or open-collector versions ('LS355 and 'LS357).

The SN54LS354 through SN54LS357 are characterized for operation over the full military temperature range of -55°C to 125°C; the SN74LS354 through SN74LS357 are characterized for operation from 0°C to 70°C.

SN54LS354, SN54LS355 ... J PACKAGE  
SN74LS354, SN74LS355 ... DW, J OR N PACKAGE  
(TOP VIEW)

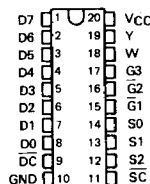

SN54LS354, SN54LS355 ... FK PACKAGE  
SN74LS354, SN74LS355 ... FN PACKAGE  
(TOP VIEW)

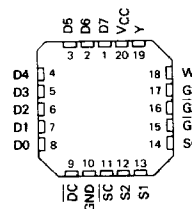

SN54LS356, SN54LS357 ... J PACKAGE  
SN74LS357, SN74LS357 ... DW, J OR N PACKAGE  
(TOP VIEW)

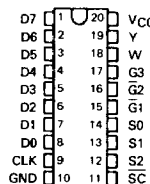

SN54LS356, SN54LS357 ... FK PACKAGE  
SN74LS356, SN74LS357 ... FN PACKAGE  
(TOP VIEW)

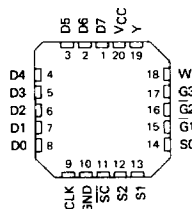

3

TTL DEVICES

## PRODUCTION DATA

This document contains information current as of publication date. Products conform to specifications per the terms of Texas Instruments standard warranty. Production processing does not necessarily include testing of all parameters.

TEXAS  
INSTRUMENTS

POST OFFICE BOX 225012 • DALLAS, TEXAS 75265

3-1001

**TYPES SN54LS354, SN54LS355, SN54LS356, SN54LS357,  
SN74LS354, SN74LS355, SN74LS356, SN74LS357**  
**8-LINE TO 1-LINE DATA SELECTORS/MULTIPLEXERS/REGISTERS**

**FUNCTION TABLE**

SELECT			INPUTS		OUTPUT ENABLES			OUTPUTS	
S2	S1	S0	DATA CONTROL ('LS354, 'LS355)	CLOCK ('LS356, 'LS357)	G1	G2	G3	W	Y
X	X	X	X	X	H	X	X	Z	Z
X	X	X	X	X	X	H	X	Z	Z
X	X	X	X	X	X	X	L	Z	Z
L	L	L	L	L	L	L	H	$\bar{D}0$	$\bar{D}0$
L	L	L	H	H	L	L	H	$\bar{D}0_n$	$\bar{D}0_n$
L	L	H	L	L	L	L	H	$\bar{D}1$	D1
L	L	H	H	H	L	L	H	$\bar{D}1_n$	D1_n
L	H	L	L	L	L	L	H	$\bar{D}2$	D2
L	H	L	H	H	L	L	H	$\bar{D}2_n$	D2_n
L	H	H	L	L	L	L	H	$\bar{D}3$	D3
L	H	H	H	H	L	L	H	$\bar{D}3_n$	D3_n
H	L	L	L	L	L	L	H	$\bar{D}4$	D4
H	L	L	H	H	L	L	H	$\bar{D}4_n$	D4_n
H	L	H	L	L	L	L	H	$\bar{D}5$	D5
H	L	H	H	H	L	L	H	$\bar{D}5_n$	D5_n
H	H	L	L	L	L	L	H	$\bar{D}6$	D6
H	H	L	H	H	L	L	H	$\bar{D}6_n$	D6_n
H	H	H	L	L	L	L	H	$\bar{D}7$	D7
H	H	H	H	H	L	L	H	$\bar{D}7_n$	D7_n

H = high level (steady state)  
 L = low level (steady state)  
 X = irrelevant (any input, including transitions)  
 Z = high-impedance state (off state)  
 = transition from low to high level  
 D0 ... D7 = the level of steady-state inputs at inputs D0 through D7, respectively, at the time of the low-to-high clock transition in the case of 'LS356 and 'LS357  
 D0\_n ... D7\_n = the level of steady state inputs at inputs D0 through D7, respectively, before the most recent low-to-high transition of data control or clock  
 This column shows the input address setup with  $\bar{S}C$  low.

**schematics of inputs and outputs**

**EQUIVALENT OF EACH DATA OR SELECT INPUT**

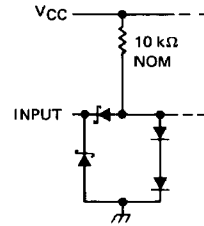

**EQUIVALENT OF ALL OTHER INPUTS**

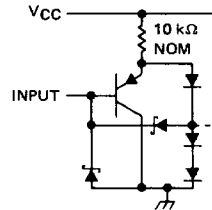

**TYPICAL OF BOTH OUTPUTS ON 'LS354 AND 'LS356**

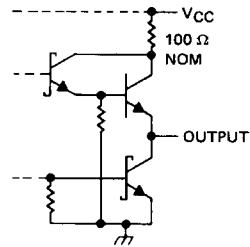

**TYPICAL OF BOTH OUTPUTS ON 'LS355 AND 'LS357**

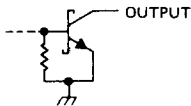

**absolute maximum ratings over operating free-air temperature range (unless otherwise noted)**

Supply voltage (see Note 1)	7 V
Input voltage	7 V
Operating free-air temperature range: SN54LS'	-55° C to 125° C
SN74LS'	0° C to 70° C
Storage temperature range	-65° C to 150° C

NOTE 1: Voltage values are with respect to network ground terminal.

**3**

**TTL DEVICES**

**TYPES SN54LS354, SN54LS355, SN54LS356, SN54LS357,  
SN74LS354, SN74LS355, SN74LS356, SN74LS357**  
**8-LINE TO 1-LINE DATA SELECTORS/MULTIPLEXERS/REGISTERS**

logic symbols

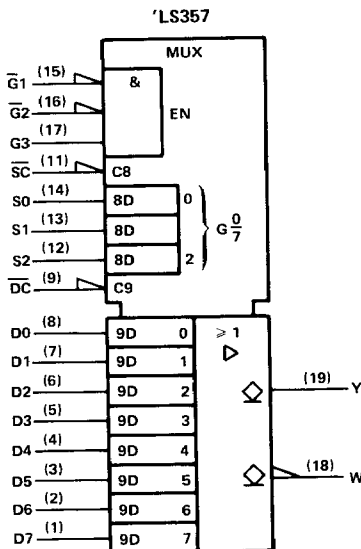
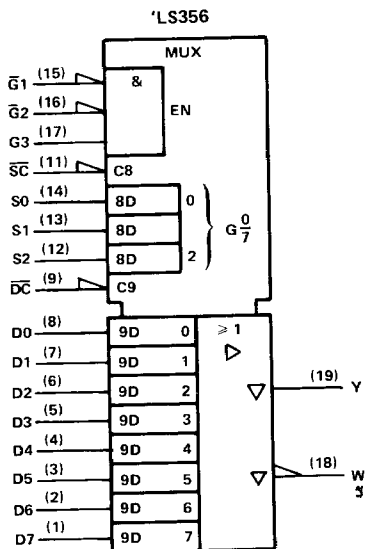
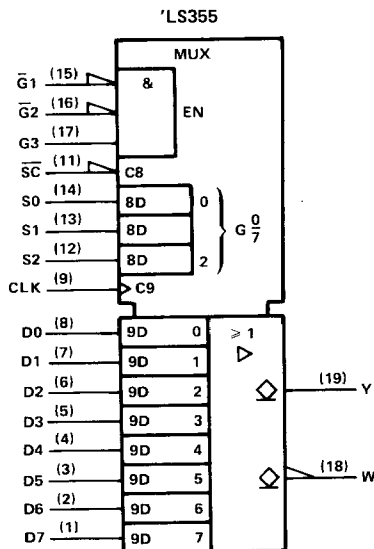
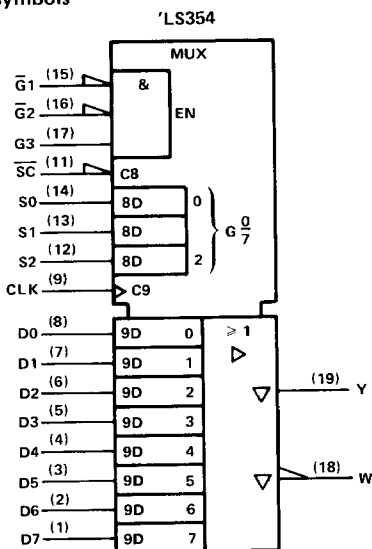

Pin numbers shown on logic notation are for DW, J or N packages.

3

TTL DEVICES

**TEXAS**  
**INSTRUMENTS**

POST OFFICE BOX 225012 • DALLAS, TEXAS 75285

3-1003

**TYPES SN54LS354, SN54LS355, SN74LS354, SN74LS355**  
**8-LINE TO 1-LINE DATA SELECTORS/MULTIPLEXERS/REGISTERS**

logic diagram (positive logic)

'LS354, 'LS355

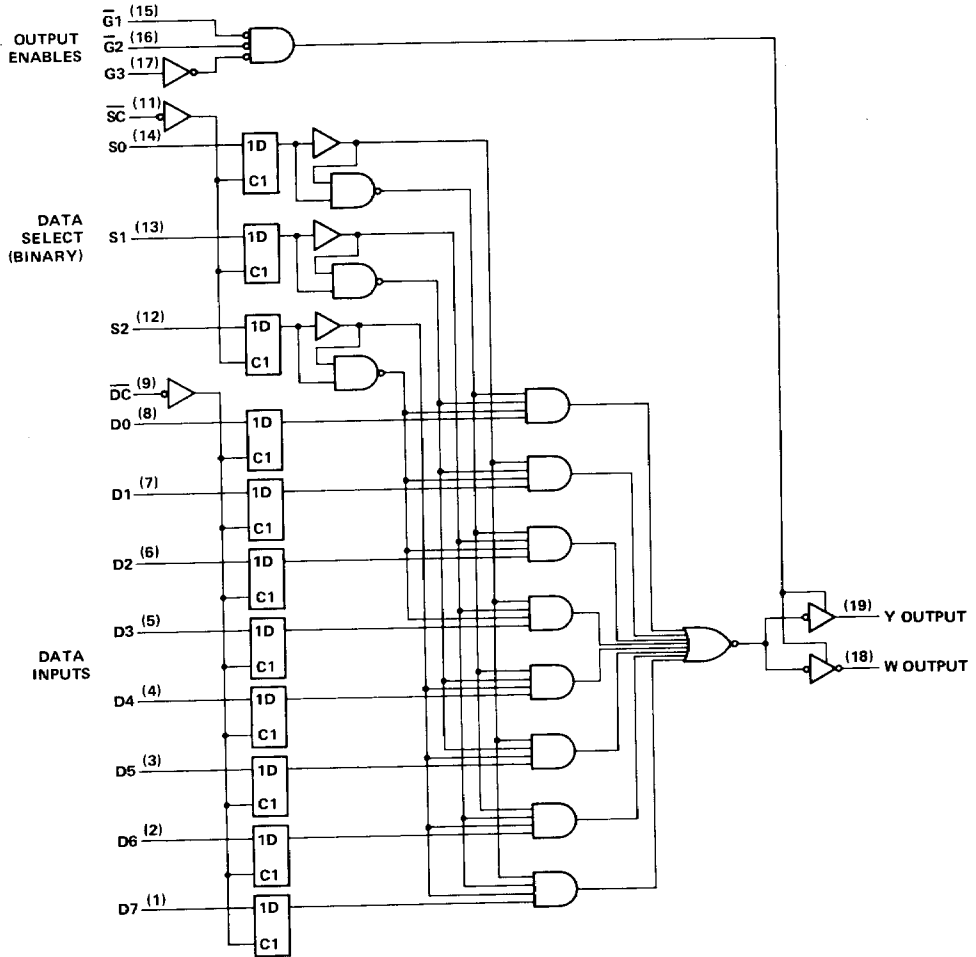

Pin numbers shown on logic notation are for DW, J or N packages.

**3**  
**TTL DEVICES**

# TYPES SN54LS356, SN54LS357, SN74LS356, SN74LS357 8-LINE TO 1-LINE DATA SELECTORS/MULTIPLEXERS/REGISTERS

logic diagram (positive logic)

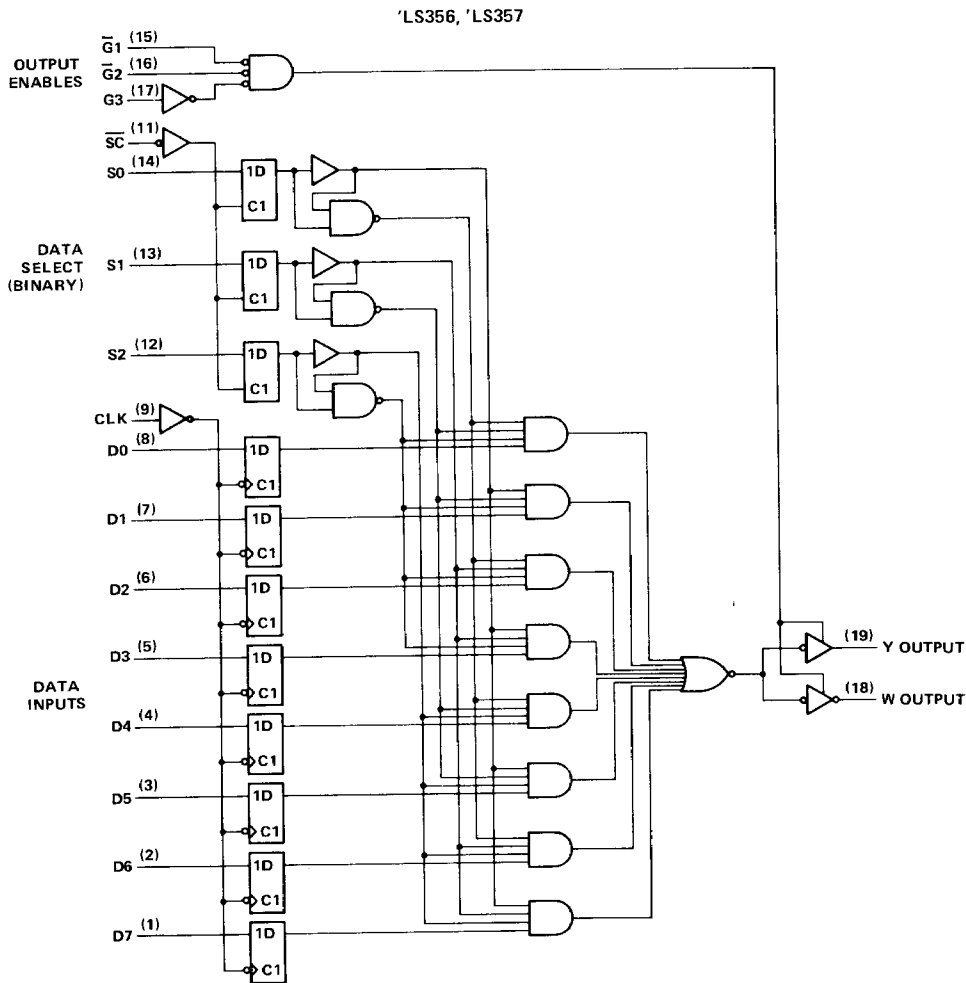

Pin numbers shown on logic notation are for DW, J or N packages.

3

TTL DEVICES

# TYPES SN54LS354, SN54LS356, SN74LS354, SN74LS356

## 8-LINE TO 1-LINE DATA SELECTORS/MULTIPLEXERS/REGISTERS

### WITH 3-STATE OUTPUTS

#### recommended operating conditions

	SN54LS354 SN54LS356			SN74LS354 SN74LS356			UNIT
	MIN	NOM	MAX	MIN	NOM	MAX	
V <sub>CC</sub> Supply voltage	4.5	5	5.5	4.75	5	5.25	V
V <sub>IH</sub> High-level input voltage	2			2			V
V <sub>IL</sub> Low-level input voltage			0.7			0.8	V
I <sub>OH</sub> High-level output current			-1			-2.6	mA
I <sub>OL</sub> Low-level output current			12			24	mA
t <sub>su</sub> Setup times, high-or-low-level data (with respect to $\uparrow$ at pin 9)	'LS354	15		15			ns
	'LS356	15		15			
t <sub>h</sub> Hold times, high-or-low-level data (with respect to $\uparrow$ at pin 9)	'LS354	15		15			ns
	'LS356	0		0			
T <sub>A</sub> Operating free-air temperature	-55		125	0		70	°C

#### electrical characteristics over recommended operating free-air temperature range (unless otherwise noted)

PARAMETER	TEST CONDITIONS†	SN54LS354 SN54LS356		SN74LS354 SN74LS356		UNIT	
		MIN	TYP‡	MAX	MIN		TYP‡
V <sub>IK</sub>	V <sub>CC</sub> = MIN, I <sub>I</sub> = -18 mA			-1.5		-1.5	V
V <sub>OH</sub>	V <sub>CC</sub> = MIN, V <sub>IH</sub> = 2 V, V <sub>IL</sub> = MAX, I <sub>OH</sub> = MAX	2.4			2.4		V
V <sub>OL</sub>	V <sub>CC</sub> = MIN, V <sub>IH</sub> = 2 V, V <sub>IL</sub> = MAX	I <sub>OL</sub> = 12 mA	0.25	0.4	0.25	0.4	V
		I <sub>OL</sub> = 24 mA			0.35	0.5	
I <sub>OZ</sub>	V <sub>CC</sub> = MAX	V <sub>O</sub> = 2.7 V		20		20	μA
		V <sub>O</sub> = 0.4 V		-20		-20	
I <sub>I</sub>	V <sub>CC</sub> = MAX, V <sub>I</sub> = 7 V			0.1		0.1	mA
I <sub>IH</sub>	V <sub>CC</sub> = MAX, V <sub>I</sub> = 2.7 V			20		20	μA
I <sub>IL</sub>	DC or CLK, $\bar{G}1, \bar{G}2, \bar{G}3$ All others	V <sub>CC</sub> = MAX, V <sub>I</sub> = 0.4 V		-0.2		-0.2	mA
				-0.4		-0.4	
I <sub>OS</sub> §	V <sub>CC</sub> = MAX	-30		-130	-30	-130	mA
I <sub>CC</sub>	V <sub>CC</sub> = MAX, See Note 2		29	46	29	46	mA

† For conditions shown as MIN or MAX, use the appropriate values specified under recommended operating conditions.

‡ All typical values are at V<sub>CC</sub> = 5 V, T<sub>A</sub> = 25°C.

§ Not more than one output should be shorted at a time, and duration of the short-circuit should not exceed one second.

NOTE 2: I<sub>CC</sub> is measured with the inputs grounded and the outputs open.

3 TTL DEVICES

# TYPES SN54LS354, SN54LS356, SN74LS354, SN74LS356

## 8-LINE TO 1-LINE DATA SELECTORS/MULTIPLEXERS/REGISTERS WITH 3-STATE OUTPUTS

switching characteristics,  $V_{CC} = 5\text{ V}$ ,  $T_A = 25^\circ\text{C}$ ,  $R_L = 667\ \Omega$

PARAMETER	FROM (INPUT)	TO (OUTPUT)	TEST CONDITIONS	'LS354		'LS356		UNIT				
				MIN	TYP	MAX	MIN		TYP	MAX		
$t_{PLH}$	D0-D7	Y	$C_L = 45\text{ pF}$ , See Note 3	24		36		ns				
$t_{PHL}$				23		35						
$t_{PLH}$		W		18		27		ns				
$t_{PHL}$				29		44						
$t_{PLH}$	$\overline{DC}$ or CLK	Y		28		42	18	27	ns			
$t_{PHL}$				26		39	33	50				
$t_{PLH}$		W		22		33	24	36	ns			
$t_{PHL}$				33		50	18	27				
$t_{PLH}$	S0, S1 S2	Y		29		44	30	45	ns			
$t_{PHL}$				24		45	28	48				
$t_{PLH}$		W		28		42	36	54	ns			
$t_{PHL}$				34		51	30	45				
$t_{PLH}$	$\overline{SC}$	Y		34		51	36	54	ns			
$t_{PHL}$				31		47	40	60				
$t_{PLH}$		W		27		41	32	48	ns			
$t_{PHL}$				40		60	36	54				
$t_{PZH}$	$\overline{G1}, \overline{G2}$	Y	$C_L = 5\text{ pF}$ , See Note 3	14		27	14	25	ns			
$t_{PZL}$				18		27	17	25				
$t_{PHZ}$				15		25	16	24				
$t_{PLZ}$				15		25	16	24				
$t_{PZH}$				W	$C_L = 45\text{ pF}$ , See Note 3	12		24		14	23	ns
$t_{PZL}$						16		24		16	23	
$t_{PHZ}$		15				25	16	23				
$t_{PLZ}$		15				25	16	23				
$t_{PZH}$		Y	$C_L = 45\text{ pF}$ , See Note 3			15		29	15	27	ns	
$t_{PZL}$						19		29	18	27		
$t_{PHZ}$				15		25	16	25				
$t_{PLZ}$				15		25	16	25				
$t_{PZH}$	W			$C_L = 45\text{ pF}$ , See Note 3	13		25	14	25	ns		
$t_{PZL}$					17		25	16	25			
$t_{PHZ}$		15			25	16	25					
$t_{PLZ}$		15			25	16	25					

NOTE 3: See General Information Section for load circuits and voltage waveforms.

3

TTL DEVICES

**TYPES SN54LS355, SN54LS357, SN74LS355, SN74LS357**  
**8-LINE TO 1-LINE DATA SELECTORS/MULTIPLEXERS/REGISTERS**  
**WITH OPEN-COLLECTOR OUTPUTS**

**recommended operating conditions**

		SN54LS355 SN54LS357			SN74LS355 SN74LS357			UNIT
		MIN	NOM	MAX	MIN	NOM	MAX	
V <sub>CC</sub>	Supply voltage	4.5	5	5.5	4.75	5	5.25	V
V <sub>IH</sub>	High-level input voltage	2			2			V
V <sub>IL</sub>	Low-level input voltage				0.7			V
V <sub>OH</sub>	High-level output voltage				5.5			V
I <sub>OL</sub>	Low-level output current				12			mA
t <sub>su</sub>	Setup times, high-or-low-level data, (with respect to t <sub>f</sub> at pin 9)	'LS355	15		15			ns
		'LS357	15		15			
t <sub>h</sub>	Hold times, high-or low-level data (with respect to t <sub>f</sub> at pin 9)	'LS355	15		15			ns
		'LS357	0		0			
T <sub>A</sub>	Operating free-air temperature	- 55		125		0		70 °C

**electrical characteristics over recommended operating free-air temperature range (unless otherwise noted)**

PARAMETER	TEST CONDITIONS†	SN54LS355 SN54LS357			SN74LS355 SN74LS357			UNIT
		MIN	TYP‡	MAX	MIN	TYP‡	MAX	
V <sub>IK</sub>	V <sub>CC</sub> = MIN, I <sub>I</sub> = - 18 mA	- 1.5			- 1.5			V
I <sub>OH</sub>	V <sub>CC</sub> = MIN, V <sub>IH</sub> = 2 V, V <sub>OH</sub> = 5.5 V, V <sub>IL</sub> = MAX	0.1			0.1			mA
V <sub>OL</sub>	V <sub>CC</sub> = MIN, V <sub>IH</sub> = 2 V, V <sub>IL</sub> = MAX	I <sub>OL</sub> = 12 mA		0.25	0.4	0.25	0.4	V
		I <sub>OL</sub> = 24 mA				0.35	0.5	
I <sub>I</sub>	V <sub>CC</sub> = MAX, V <sub>I</sub> = 7 V	0.1			0.1			mA
I <sub>IH</sub>	V <sub>CC</sub> = MAX, V <sub>I</sub> = 2.7 V	20			20			µA
I <sub>IL</sub>	DC or CLK, G1, G2, G3	V <sub>CC</sub> = MAX, V <sub>I</sub> = 0.4 V		- 0.2		- 0.2		mA
	All others			- 0.4		- 0.4		
I <sub>CC</sub>	V <sub>CC</sub> = MAX, See Note 2	29	46	29	46	mA		

† For conditions shown as MIN or MAX, use the appropriate value specified under recommended operating conditions for the applicable type.

‡ All typical values are at V<sub>CC</sub> = 5 V, T<sub>A</sub> = 25°C.

NOTE 2: I<sub>CC</sub> is measured with the inputs grounded and the outputs open.

**3**  
**TTL DEVICES**



**TYPES SN54LS355, SN54LS357, SN74LS355, SN74LS357**  
**8-LINE TO 1-LINE DATA SELECTORS/MULTIPLEXERS/REGISTERS**  
**WITH OPEN-COLLECTOR OUTPUTS**

switching characteristics,  $V_{CC} = 5\text{ V}$ ,  $T_A = 25^\circ\text{C}$ ,  $R_L = 667\ \Omega$

PARAMETER <sup>1</sup>	FROM (INPUT)	TO (OUTPUT)	TEST CONDITIONS	'LS355			'LS357			UNIT
				MIN	TYP	MAX	MIN	TYP	MAX	
$t_{PLH}$	D0-D7	Y	$C_L = 45\ \text{pF}$ , See Note 3	34		41				ns
$t_{PHL}$				26		39				
$t_{PLH}$		W		30		45				ns
$t_{PHL}$				33		50				
$t_{PLH}$	$\overline{DC}$ or CLK	Y		38		57	27	41		ns
$t_{PHL}$				31		47	34	51		
$t_{PLH}$		W		33		50	32	48		ns
$t_{PHL}$				39		59	23	35		
$t_{PLH}$	S0, S1, S2	Y		39		59	38	57		ns
$t_{PHL}$				36		49	40	60		
$t_{PLH}$		W		32		48	38	57		ns
$t_{PHL}$				39		58	35	53		
$t_{PLH}$	$\overline{SC}$	Y		45		68	44	66		ns
$t_{PHL}$				42		63	41	62		
$t_{PLH}$		W		44		66	41	62		ns
$t_{PHL}$				45		68	41	62		
$t_{PHL}$	$\overline{G1}, \overline{G2}$	Y	21		32	18	27		ns	
$t_{PHL}$			22		33	18	27			
$t_{PLH}$		W	18		27	20	30		ns	
$t_{PHL}$			19		29	21	32			
$t_{PLH}$	G3	Y	24		36	24	36		ns	
$t_{PHL}$			25		40	24	36			
$t_{PLH}$		W	19		31	19	31		ns	
$t_{PHL}$			19		29	19	29			

NOTE 3: See General Information Section for load circuits and voltage waveforms.

**3**  
TTL DEVICES