



Specification For Approval

Customer : _____
Description : _____ EC FAN _____
Customer Part No. : _____ N/A _____ Rev : _____
Delta Model No. : _____ GTW012FU804 _____ Rev : 01 _____
Safety Model No. : _____
Sample Issue No. : _____
Sample Issue Date : _____ 12/05/2016 _____

Please send one copy of this specification back after you signed approval for production pre-arrangement

Approved by : _____

Date : _____

Electronically Commutated (EC) Fan

Axial Fan

120 x 120 x 38 mm



DELTA ELECTRONICS, INC.
 No.252, Shangying Road, Guishan
 Industrial Zone, Taoyuan City, 33341,
 Taiwan
 TEL: +886-3-359-1968
 FAX: +886-3-359-1991
www.deltaww.com



Technical features

Input Side	
Nominal Voltage	1~ 220Vac 50/60Hz
Input Source	1~ 100Vac - 240Vac
Power @ Free air	11 W
Power @ Max. load	11 W
Output Side	
Speed (RPM)	4200
Qmax. (CMH / CFM)	246 / 145
Pmax. (Pa / inAq)	112 / 0.45
Noise (dB-A) @ Qmax	54.9 (Max 58.9)
Functions	
INPUT PWM FOR SPEED CONTROL	
ROTATION DETECT (RD) SIGNAL OUTPUT	

Physical	
Rotation Direction	CCW, seen on rotor
Material (Impeller / Frame)	Plastic / Plastic
Bearing system	Ball bearings
Weight (kg)	0.36
Electrical leads	Lead Wire
Environmental	
Operating temperature range	-20 ~ +70 °C
Storage temperature range	-30 ~ +85 °C
Safety	
Safety	UL, cUL, TUV
IP Level	IP54
EMC	N/A
Protection class	II
Insulation class	A
Leakage current	<= 3.5 mA
Motor protection	Over temperature protected
Life expectancy	60,000 hrs at 40 °C / 15 ~ 65 %RH

NOTE : Delta reserves the right to change specifications and other product information without prior notice.

P & Q curves

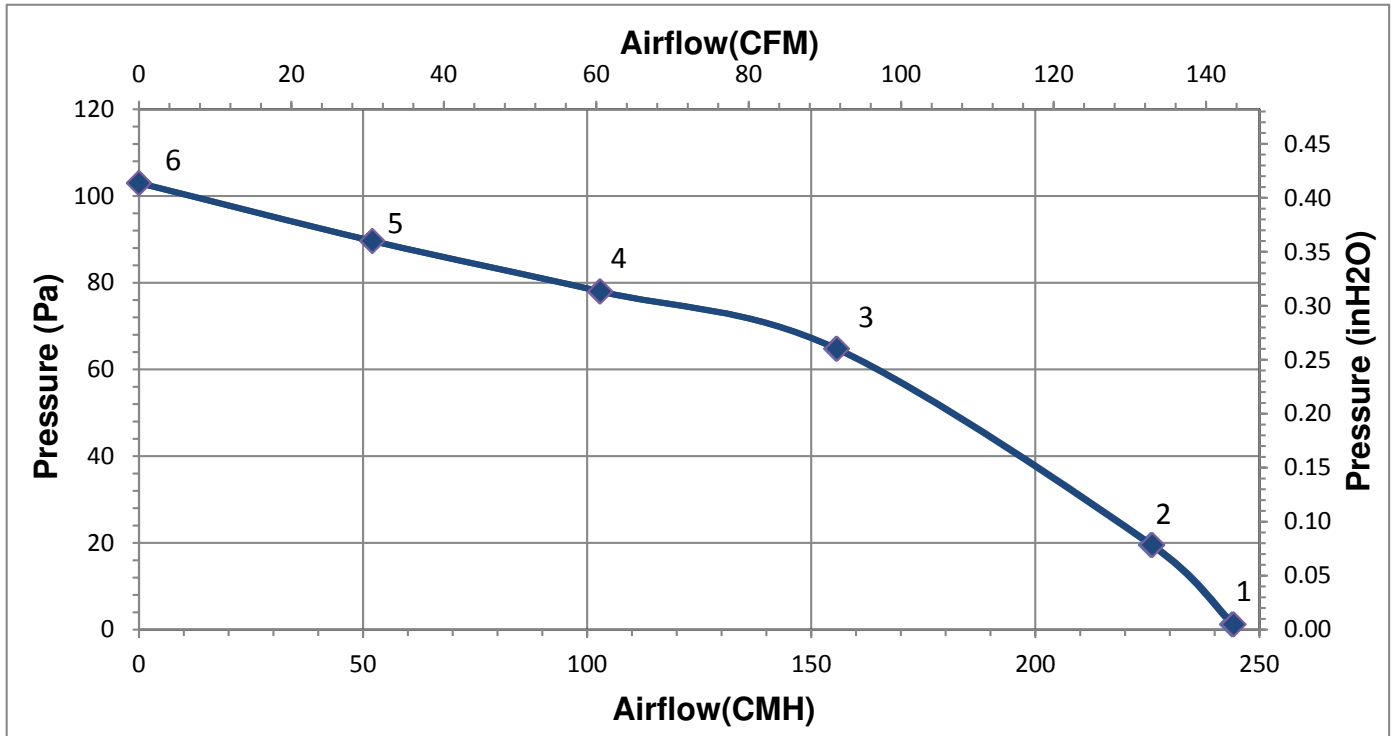

Measure data:

	P [Pa]	Q [CMH]	N [R.P.M.]	P1 [W]	I [A]	Lp [dB(A)]
1	0.0	243.9	4224	10.43	0.09	54.9
2	19.5	225.8	4074	10.37	0.09	
3	64.8	155.5	3808	10.0	0.08	
4	78.0	60.5	3847	10.0	0.08	
5	89.6	30.6	3816	10.0	0.08	
6	103.0	0.0	3330	9.4	0.08	

Test Condition:

- Input Voltage: Nominal Voltage
- Temperature : Room Temperature
- Humidity : 65%RH
- Measured without Fan guard
- Noise (Lp) is measured at a distance of one meter from the outlet side.

Dimension drawing

Label :

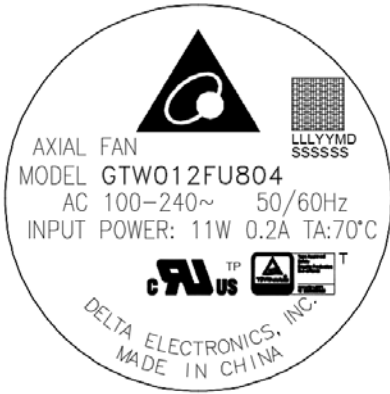

Fan :

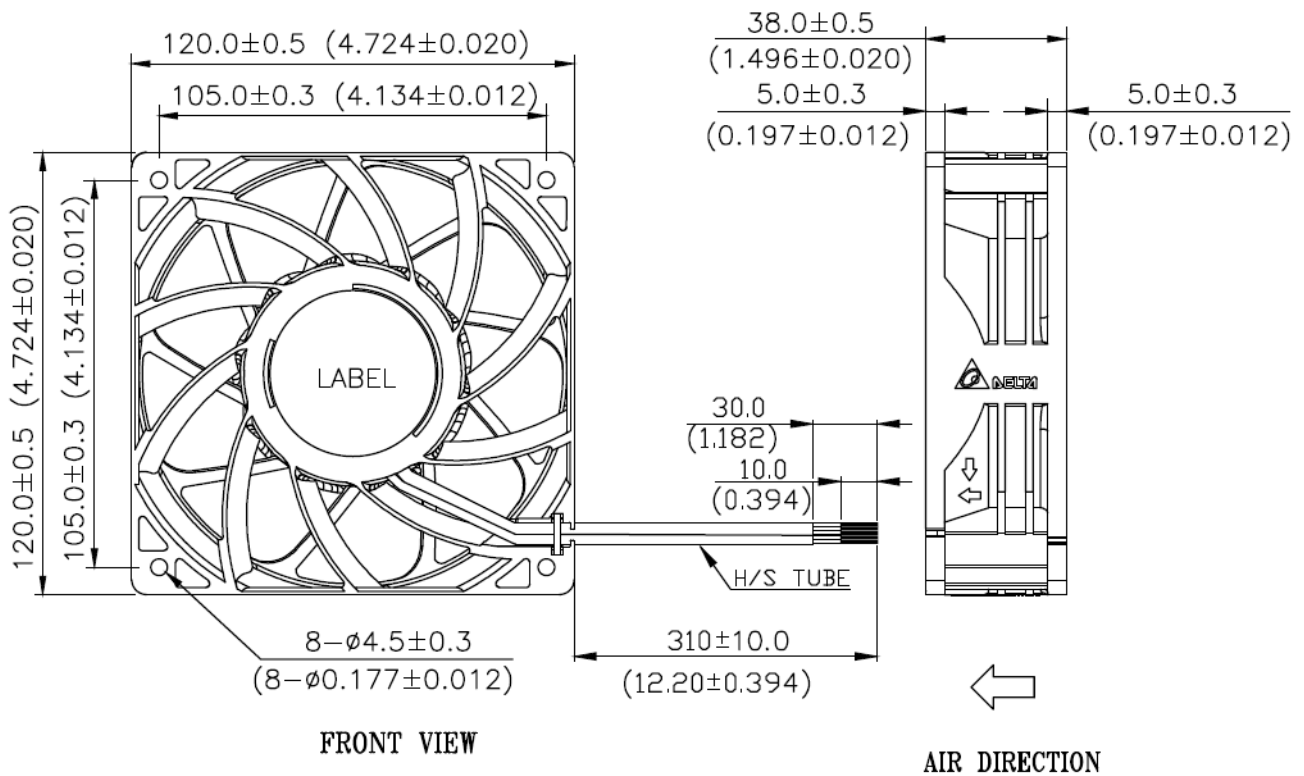

UNIT: mm [INCH]

Note:

1. CABLE DIAMETER: $\phi 1.9 \sim \phi 3.0$ mm
2. THIS PRODUCT IS RoHS COMPLIANT.

Lead wire connection:

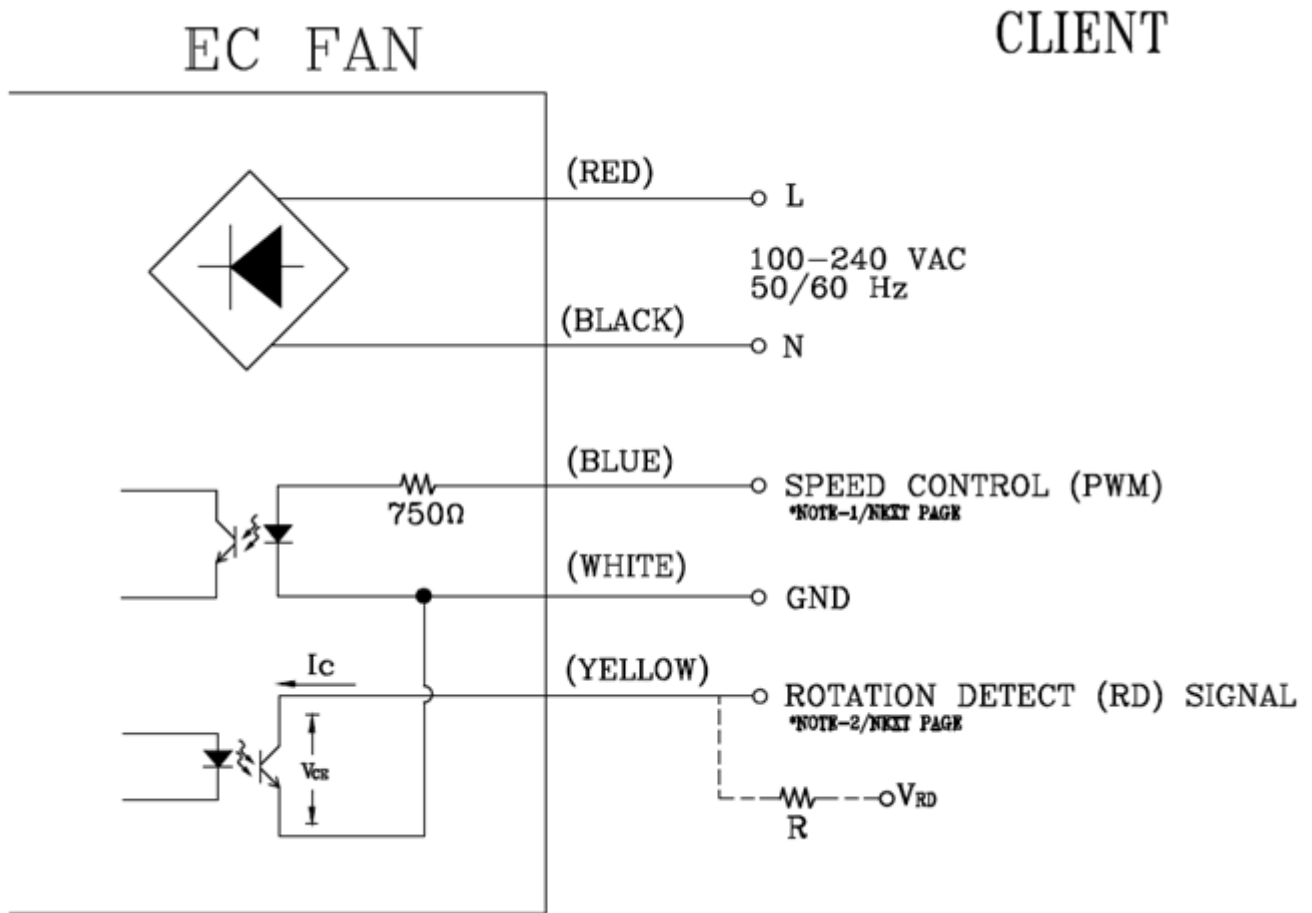

FUNCTION CONTROL:

*NOTE-1: PWM SPEED CONTROL SIGNAL

- THE AMPLITUDE VOLTAGE SHALL BE MAX. 12.5VDC. (25K Hz)

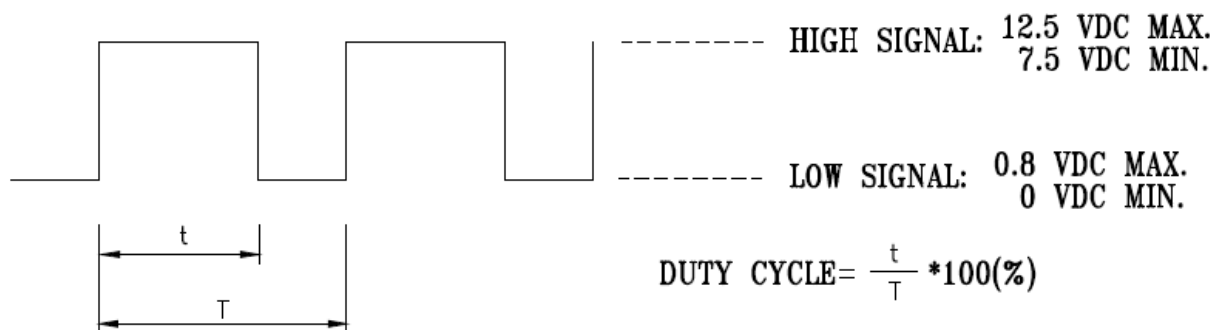

- THE SPEED COMPARISON WITH CONTROL LEVEL (FREE AIR):

PWM DUTY	SPEED R.P.M. (REF.)	POWER (W)
100%	4200 ± 10%	11.0
0%	0	0.01

- WITH CONTROL SIGNAL LEAD DISCONNECTED, THE FAN WILL STOP SPIN.

- AT 25K Hz 30% DUTY CYCLE, THE FAN WILL BE ABLE TO START FROM A DEAD STOP.

*NOTE-2: ROTATION DETECT (RD) SIGNAL

$V_{CE}(\text{sat}) = 0.5V \text{ MAX.}$

$V_{RD} = 27.6V \text{ MAX.}$

$I_C = 5mA \text{ MAX.}$

$R \geq V_{RD}/I_C$

ROTATION DETECT WAVEFORM:

