



**HS Compact
Handheld Transmitter
Data Guide**

Wireless made simple[®]

Warning: Some customers may want Linx radio frequency (“RF”) products to control machinery or devices remotely, including machinery or devices that can cause death, bodily injuries, and/or property damage if improperly or inadvertently triggered, particularly in industrial settings or other applications implicating life-safety concerns (“Life and Property Safety Situations”).

NO OEM LINX REMOTE CONTROL OR FUNCTION MODULE SHOULD EVER BE USED IN LIFE AND PROPERTY SAFETY SITUATIONS. No OEM Linx Remote Control or Function Module should be modified for Life and Property Safety Situations. Such modification cannot provide sufficient safety and will void the product’s regulatory certification and warranty.

Customers may use our (non-Function) Modules, Antenna and Connectors as part of other systems in Life Safety Situations, but only with necessary and industry appropriate redundancies and in compliance with applicable safety standards, including without limitation, ANSI and NFPA standards. It is solely the responsibility of any Linx customer who uses one or more of these products to incorporate appropriate redundancies and safety standards for the Life and Property Safety Situation application.

Do not use this or any Linx product to trigger an action directly from the data line or RSSI lines without a protocol or encoder/decoder to validate the data. Without validation, any signal from another unrelated transmitter in the environment received by the module could inadvertently trigger the action.

All RF products are susceptible to RF interference that can prevent communication. RF products without frequency agility or hopping implemented are more subject to interference. This module does have a frequency hopping protocol built in, but the developer should still be aware of the risk of interference.

Do not use any Linx product over the limits in this data guide. Excessive voltage or extended operation at the maximum voltage could cause product failure. Exceeding the reflow temperature profile could cause product failure which is not immediately evident.

Do not make any physical or electrical modifications to any Linx product. This will void the warranty and regulatory and UL certifications and may cause product failure which is not immediately evident.

Table of Contents

- 1 [Description](#)
- 1 [Features](#)
- 1 [Applications](#)
- 2 [Ordering Information](#)
- 2 [Electrical Specifications](#)
- 3 [Theory of Operation](#)
- 4 [Security Overview](#)
- 6 [Typical System Setup](#)
- 7 [Using the Optional Keypad Pin](#)
- 8 [Contention Considerations](#)
- 8 [Battery Replacement](#)
- 8 [OTX-***-HH-CP8-HS Button Assignments](#)
- 9 [Assembly Diagram](#)
- 10 [Typical Applications](#)
- 12 [Labeling / Instruction Requirements](#)
- 13 [Master Development System](#)
- 15 [Resources](#)

HS Compact Handheld Transmitter

Data Guide



Description

The Linx OTX-***-HH-CP8-HS Compact Handheld Transmitter is ideal for general-purpose remote control and command applications which require high security. This unit has been pre-certified for FCC Part 15, Industry Canada, and European CE (433MHz only) compliance, reducing costs and time to market. Available in 315, 418 (standard), or 433.92MHz, this small remote has a transmission range of up to 750 feet (230m) when combined with an LR or LT Series module. It can be configured with 1 to 8 buttons and the keypad and labeling can be customized. Security is dramatically enhanced by the on-board HS Series encoder, which uses Cipherlinx™ technology, a high-security encryption algorithm and wireless protocol. When paired with an HS Series decoder, transmitter identity can be determined and button permissions established. The unit uses a single 3V CR2032 lithium button cell.

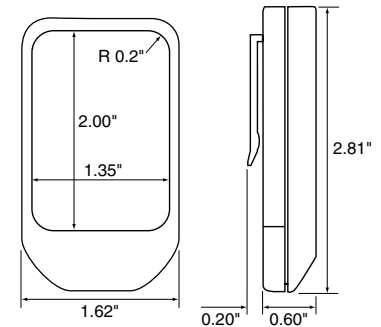

Figure 1: Package Dimensions



Figure 2: With a one-time NRE and minimum order, Linx can configure the keypad and label areas to meet your specific requirements.

Features

- FCC, Canada and CE pre-certified
- High security
- 1 to 8 buttons
- Small package
- Customizable keypad

Applications

- General remote control
- Keyless entry
- Garage / gate openers
- Lighting control
- Call systems
- Home / industrial automation
- Wire elimination

Ordering Information

Ordering Information	
Part Number	Description
OTX-***-HH-CP8-HS-xxx	HS Compact Handheld Transmitter
MDEV-***-HH-CP8-HS	HS Compact Transmitter Master Development System

*** = 315, 418 (Standard) or 433.92MHz
xxx = Custom color, leave blank for black

Figure 3: Ordering Information

Electrical Specifications

Electrical Specifications						
Parameter	Designation	Min.	Typ.	Max.	Units	Notes
Power Supply						
Operating Voltage	V_{CC}	2.1	3.0	3.6	VDC	
Supply Current	I_{CC}		3.4		mA	
Power-Down Current	I_{PDN}		5.0		nA	1
Transmitter Section						
Transmit Frequency Range	F_c					
OTX-315-HH-LR8-HS			315		MHz	
OTX-418-HH-LR8-HS			418		MHz	
OTX-433-HH-LR8-HS			433.92		MHz	
Center Frequency Accuracy		-50		+50	kHz	
Environmental						
Operating Temperature Range		-40		+85	°C	1

1. Characterized, but not tested

Figure 4: Electrical Specifications

Theory of Operation

The OTX-***-HH-CP8-HS Compact Handheld Transmitter combines an LR Series transmitter and an antenna with an on-board HS Series encoder to form a highly reliable and secure RF remote-control transmitter. The LR Series transmitter is a low-cost, high-performance synthesized OOK transmitter. Its synthesized architecture delivers outstanding stability and frequency accuracy, while minimizing the effects of antenna port loading and mismatching. This reduces or eliminates frequency pulling, bit contraction, and other negative effects that are common to SAW-based transmitter architectures, providing a significantly higher level of performance and reliability.

When a button is pressed on the transmitter, power is applied to the internal circuitry and the encoder is enabled. The encoder then detects the logic states of the button data lines. These states are formatted into an encrypted message that is output to the transmitter module. This cycle continues until the button is released. The encoder data is used to modulate the transmitter, which conveys the data into free space through the antenna. Once data is received, a decoder IC is used to decrypt the transmitter's commands. If decryption is successful, the decoder's outputs are set to replicate the transmitter's button states. These outputs can then be used to activate external circuitry required by the application.

The transmitter is compatible with the LT and LR product families. For applications where range is critical, the LR Series receiver is the best choice due to its outstanding sensitivity. When the transmitter is combined with an LR Series receiver and an HS Series decoder, ranges of up to 750 feet (230m) are possible. Applications operating over shorter distances also benefit from the increased link reliability and superior noise immunity provided by the LR Series receiver.

Security Overview

The HS Compact Handheld transmitter uses the HS Series encoder, which is based on CipherLinx™ technology. CipherLinx™ is a high-security encryption algorithm and wireless protocol designed for remote control and remote keyless entry applications. It provides a much greater level of security and many more features than older technologies on the market, such as fixed address or “rolling code” systems. Additionally, the CipherLinx™ protocol is much more advanced than the simple PWM method employed by many systems. By utilizing an advanced serial protocol, CipherLinx™ is able to offer superior noise immunity, greater range, and greater link reliability, all of which are key factors in a wireless system.

CipherLinx™ never sends or accepts the same data twice, never loses sync, and changes codes with every packet, not just every button press. The encryption that is used in CipherLinx™ is based on the Skipjack cipher developed by the U.S. National Security Agency (NSA), and is widely considered one of the most secure ciphers available. The CipherLinx™ algorithm has been evaluated by Independent Security Evaluators (ISE), a company that has testified before Congress as experts on electronic security. They concluded that “In short, the CipherLinx™ protocol in the HS Series is well-designed and is an excellent choice for applications requiring a secure unidirectional link.”

In addition to this high level of security, CipherLinx™ also offers a number of features that are unique among remote control products. These include a large number of data lines, internal key generation, “button level” control permissions, an optional encoder PIN, as well as the ability for the decoder to identify the originating encoder.

CipherLinx™ is based on the NSA-designed cipher Skipjack. Skipjack is a block cipher that has 80-bit keys and 64-bit data blocks. Since each packet is longer than 64 bits, Skipjack must be employed in an encryption mode. The particular encryption mode chosen for CipherLinx™ is based on the CMC encryption mode, so that the resulting cipher is a special kind of function known as a “strong PRP” (sPRP). The encryption mode uses several invocations of Skipjack to encrypt the 128 bits in each message. The definition of these terms is quite involved, but more details can be found in ISE’s evaluation report at www.linxtechnologies.com.

The HS Series uses a 40-bit counter to change the appearance of each message. This large counter value and the timing associated with the protocol ensure that the same message is never sent twice and prevents the encoder from ever losing sync with the decoder.

The user generates the key with the decoder through multiple button presses. This ensures that the key is random and chosen from among all 2^{80} possible keys. Since all of the keys are created by the user and are internal to the part, there is no list of numbers or seed values anywhere that could be accessed to compromise the system.

The user or manufacturer may also set “button level” Control Permissions. Control Permissions determine how the decoder responds to the reception of a valid command, either allowing the activation of an individual data line or not. The decoder is programmed with the permission settings during set-up, and those permissions are retained in the decoder’s non-volatile memory.

Typical System Setup

The HS Series Compact Handheld Transmitter is intended to make user setup straightforward while ensuring the highest possible security. This inherent ease of use can be illustrated by a typical user setup. The Typical Applications section of the HS Series Decoder Data Guide shows the circuit schematics on which the receiver examples are based.

1. Create an exchange a key from a decoder to the transmitter.

The handheld transmitter includes an on-board infrared receiver designed to optically receive the decoder's key transmission. Sending the key in this manner preserves security while avoiding the need for a hardware connection.

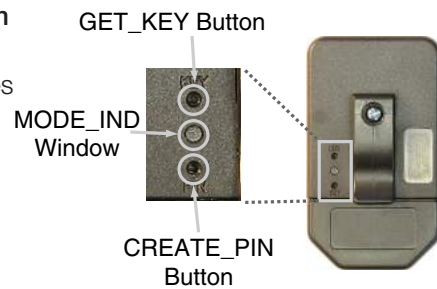

Figure 5: Button Access Holes

The high security key is created and exchanged by placing the decoder in the Create Key Mode. The decoder's MODE_IND LED lights to indicate that the decoder has entered Create Key Mode. The decoder's CREATE_KEY button is then pressed ten times to create the key. After the tenth press, the MODE_IND LED turns off and the decoder outputs the key via a 900nm infrared diode on the KEY_OUT line. A paper clip is used to press the GET_KEY button on the back of the transmitter. Hold the back of the transmitter near the decoder's infrared diode within twenty seconds. Once the key has been transferred, the MODE_IND LEDs on both the transmitter and decoder illuminate to indicate success.

2. Establish Control Permissions

Next, the user defines which buttons on the transmitter should be acknowledged by the decoder. The HS Series Control Permissions allow each transmitter in a system to activate different data lines. This is especially useful in applications where differing user access or activation capabilities are desired.

Consider this example: a three-door garage houses Dad's Corvette, Mom's Mercedes, and Son's Yugo. With most competitive products, any keyfob could open any garage door as long as the addresses match. In an HS-based system, the keyfobs could easily be configured

to open only certain doors (guess which one Son gets to open!). Setting the control permissions is intuitive. The user presses the decoder's LEARN button. The decoder's MODE_IND LED starts flashing and the user simply presses the handheld transmitter buttons that should be recognized. Control Permissions are stored when the LEARN button is pressed again or automatically after seventeen seconds.

There are other powerful options, such as programming a user PIN or copying a decoder, but these two steps are all that is required for a typical setup.

Using the Optional Keypad Pin

For higher security applications, the HS Series encoder has the option to set a Personal Identification Number (PIN) to control access to the encoder. This PIN is a four-button combination of the eight buttons which must be entered before the transmitter will send any commands. It needs to be re-entered after fifteen minutes of inactivity. If no PIN is created, then the transmitter activates as soon as a button is pressed.

Creation of a Keypad PIN

1. Use a paper clip to press the CREATE_PIN button on the back of the transmitter. The MODE_IND LED begins flashing until either a PIN is successfully entered or fifteen seconds has passed.
2. To enter the PIN, press a sequence of any four buttons. The MODE_IND stops flashing and the PIN is created.
3. To cancel Create PIN Mode prior to the fourth entry, either wait for the fifteen second timeout to pass or press the CREATE_PIN button. The MODE_IND LED stops flashing and no PIN is created.
4. If a new KEY is created, the PIN is automatically erased.

Using the PIN

1. The PIN is entered by pressing each button until all four entries have been made. There is a maximum two-second time limit between entries, after which the PIN must be re-entered in its entirety.
2. Once the PIN is successfully entered, the transmitter is operational unless it is inactive for fifteen minutes, in which case the PIN must be re-entered.

Contention Considerations

It is important to understand that only one transmitter at a time can be activated within a reception area. While the transmitted signal consists of encoded digital data, only one carrier of any particular frequency can occupy airspace without contention at any given time. If two transmitters are activated in the same area at the same time, then the signals will interfere with each other and the decoder will not see a valid transmission, so it will not take any action.

Battery Replacement

The remote unit utilizes a standard CR2032 lithium button cell. In normal use, it provides 1 to 2 years of operation. To replace the battery, remove the access cover by pressing firmly on the label area and sliding it off. Once the unit is open, remove the battery by sliding it from beneath the holder. Replace it with the same type of battery while observing the polarity shown in Figure 6.

There may be the risk of explosion if the battery is replaced by the wrong type.

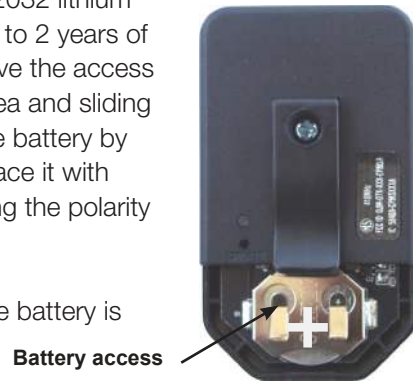

Figure 6: Battery Access

OTX-***-HH-CP8-HS Button Assignments

Figure 7 illustrates the relationship between the button locations and encoder data lines.

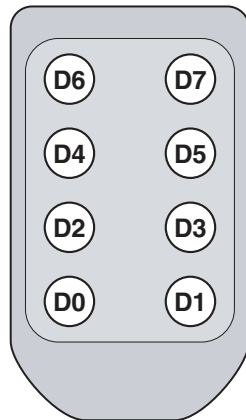

Figure 7: OTX-***-HH-CP8-HS Button Assignments

Assembly Diagram

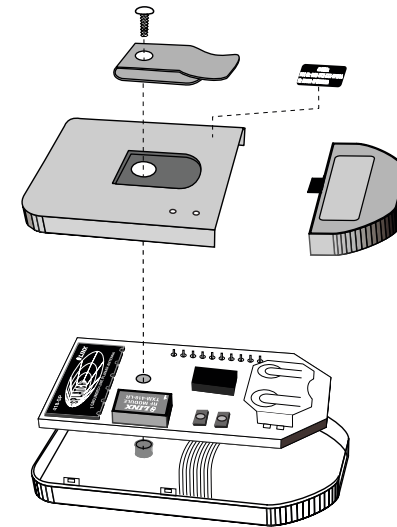

Figure 8: OTX-***-HH-CP8-HS Assembly

Typical Applications

The signal sent by the HS Compact Handheld Transmitter can be received by the LR Series receiver module or the LT Series transceiver module. The outstanding sensitivity of the LR Series receiver offers the best range when used with a Linx OEM transmitter. The receiver module is then connected directly to an HS Series decoder, which decrypts the transmitted signal.



Figure 9: Receiver and Decoder

When a button is pressed on the transmitter, a corresponding line on the decoder goes high. This is then connected to external circuitry to perform whatever function is required by the application.

The transmitter and decoder must be synchronized before they can work together. This is done by creating a new encryption key in the decoder, then transferring it to the transmitter as previously described.

Figure 10 shows a schematic for a typical receiver application. The handheld transmitter is set to 4,800bps, so the decoder's SEL_BAUD line needs to be tied low.

The decoder has several unique features, such as Send Copy, and TX_ID.

As the name suggests, "Send Copy" allows the users and associated Control Permissions of one HS Series decoder to be transferred to another. This is useful if the same users and permissions are desired at multiple locations, such as the front door and back door of a building. Please see the HS Series Decoder Data Guide for more information on this feature.

The TX_ID line outputs a number associated with the originating transmitter / encoder. Linx Application Note AN-00156 shows how to use this feature.

Data guides for the LR Series receiver, the HS encoder, and the HS decoder can be found on the Linx Technologies website at www.linxtechnologies.com.

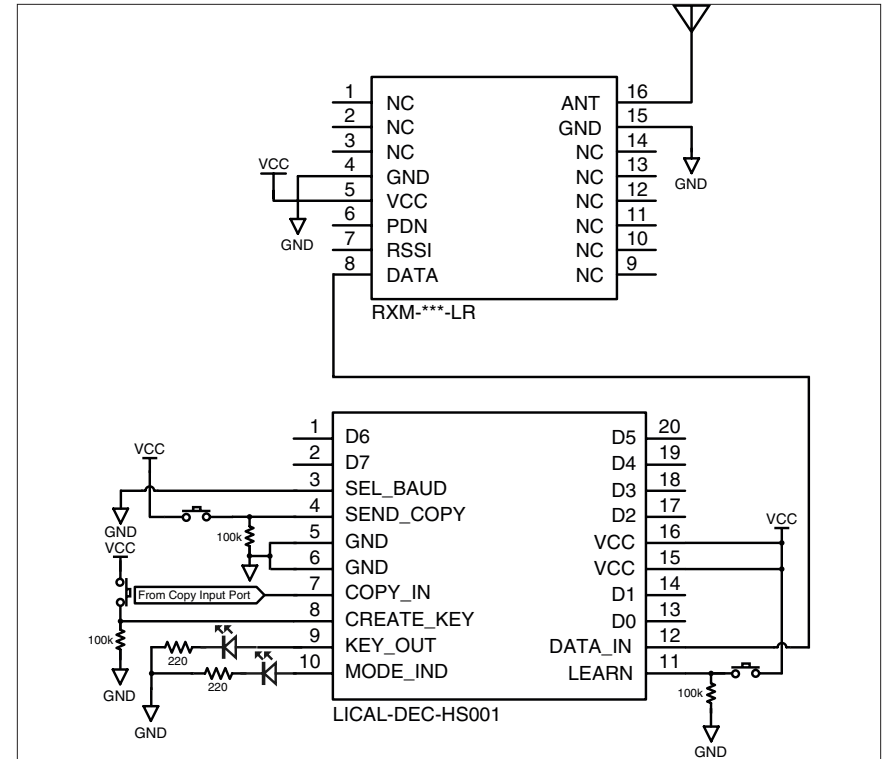

Figure 10: LR Receiver and HS Decoder Schematic

Labeling / Instruction Requirements

The transmitter has been pre-certified for FCC Part 15 and Industry Canada license-exempt RSS standards for an intentional radiator. The 433.92MHz version has also been tested for CE compliance for use in the European Union. The 315MHz and 418MHz versions are not legal for use in Europe. It has already been labeled in accordance with FCC, Industry Canada and CE regulations. No further labeling of the unit is needed; however, it is necessary to include the following statement in the end product's instruction manual or insert card. EU does not require a statement.

INSTRUCTION TO THE USER

This device complies with Part 15 of the FCC Rules and Industry Canada license-exempt RSS standard(s). Operation of this device is subject to the following two conditions:

1. This device may not cause harmful interference, and
2. This device must accept any interference received, including interference that may cause undesired operation.

This equipment has been tested and found to comply with the limits for a Class B digital device, pursuant to Part 15 of the FCC Rules. These limits are designed to provide reasonable protection against harmful interference in a residential installation. This equipment generates, uses and can radiate radio frequency energy and, if not installed and used in accordance with the instructions, may cause harmful interference to radio communications. However, there is no guarantee that interference will not occur in a particular installation. If this equipment does cause harmful interference to radio or television reception, which can be determined by turning the equipment off and on, the user is encouraged to try to correct the interference by one or more of the following measures:

- Reorient or relocate the receiving antenna.
- Increase the separation between the equipment and receiver.
- Connect the equipment into an outlet on a circuit different from that to which the receiver is connected.
- Consult the dealer or an experienced radio / TV technician for help.

The user is cautioned that changes and modifications made to the equipment without the approval of manufacturer could void the user's authority to operate this equipment.

Le présent appareil est conforme aux CNR d'Industrie Canada applicables aux appareils radioexempts de licence. L'exploitation est autorisée aux deux conditions suivantes : (1) l'appareil ne doit pas produire de brouillage, et (2) l'utilisateur de l'appareil doit accepter tout brouillage radioélectrique subi, même si le brouillage est susceptible d'en compromettre le fonctionnement.

Master Development System

The Master Development System gives a designer all the tools necessary to incorporate the HS Compact Handheld transmitter, LR Series receiver, and HS Series decoder into a product. The Master Development System serves several important functions. It allows the performance and features of the transmitter, LR Series and HS Series to be quickly evaluated. It shows how to design with the receiver and decoder and how to interface with other components. It also demonstrates the overall system function, making it easy to design the initial system design. It allows for additional circuitry to be placed directly on the board so that it can act as the first prototype of the product. All of the signals are available on a wire-wrap header for easy connection to external circuitry.



Figure 11: OTX-***-HH-CP8-HS Master Development System

When the decoder board is plugged into a USB port on a PC, the kit can be used to activate the features in the included software. When a data line goes high on the decoder, a microcontroller sends a command to the computer via a Linx USB interface module to control functions in the software. Please see the documentation included with the Development System for details.



Figure 12: The HS Series Master Development System

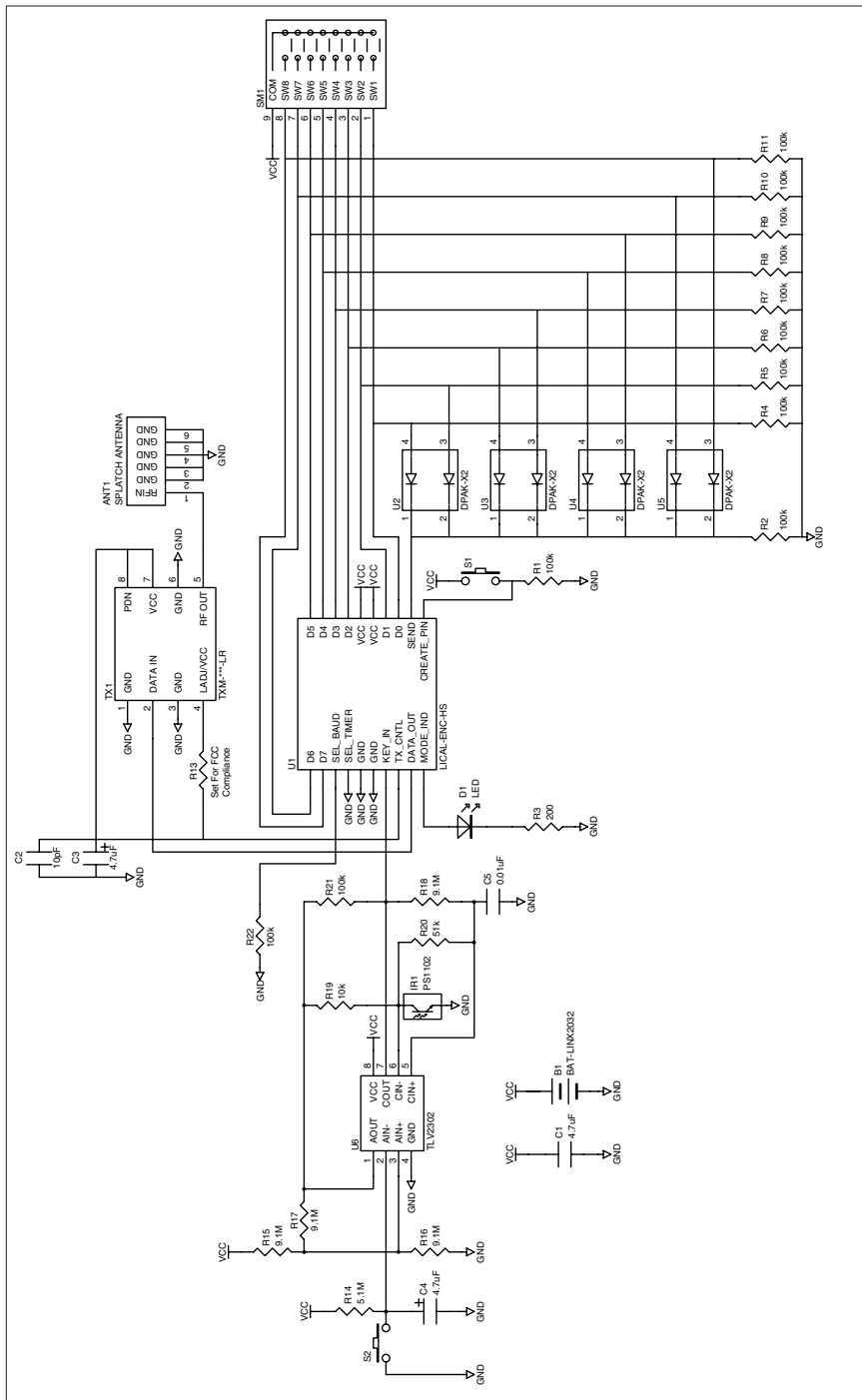

Figure 13: OTX-***-HH-CP8-HS Schematic Diagram

Resources

Support

For technical support, product documentation, application notes, regulatory guidelines and software updates, visit www.linxtechnologies.com

RF Design Services

For customers who need help implementing Linx modules, Linx offers design services including board layout assistance, programming, certification advice and packaging design. For more complex RF solutions, Apex Wireless, a division of Linx Technologies, creates optimized designs with RF components and firmware selected for the customer's application. Call +1 800 736 6677 (+1 541 471 6256 if outside the United States) for more information.

Antenna Factor Antennas

Linx's Antenna Factor division has the industry's broadest selection of antennas for a wide variety of applications. For customers with specialized needs, custom antennas and design services are available along with simulations of antenna performance to speed development. Learn more at www.linxtechnologies.com.





Linx Technologies
159 Ort Lane
Merlin, OR, US 97532

Phone: +1 541 471 6256
Fax: +1 541 471 6251
www.linxtechnologies.com

Disclaimer

Linx Technologies is continually striving to improve the quality and function of its products. For this reason, we reserve the right to make changes to our products without notice. The information contained in this Data Guide is believed to be accurate as of the time of publication. Specifications are based on representative lot samples. Values may vary from lot-to-lot and are not guaranteed. "Typical" parameters can and do vary over lots and application. Linx Technologies makes no guarantee, warranty, or representation regarding the suitability of any product for use in any specific application. It is Customer's responsibility to verify the suitability of the part for the intended application. At Customer's request, Linx Technologies may provide advice and assistance in designing systems and remote control devices that employ Linx Technologies RF products, but responsibility for the ultimate design and use of any such systems and devices remains entirely with Customer and/or user of the RF products.

LINX TECHNOLOGIES DISCLAIMS ANY AND ALL WARRANTIES OF MERCHANTABILITY AND FITNESS FOR A PARTICULAR PURPOSE. IN NO EVENT SHALL LINX TECHNOLOGIES BE LIABLE FOR ANY CUSTOMER'S OR USER'S INCIDENTAL OR CONSEQUENTIAL DAMAGES ARISING OUT OF OR RELATED TO THE DESIGN OR USE OF A REMOTE CONTROL SYSTEM OR DEVICE EMPLOYING LINX TECHNOLOGIES RF PRODUCTS OR FOR ANY OTHER BREACH OF CONTRACT BY LINX TECHNOLOGIES. CUSTOMER AND/OR USER ASSUME ALL RISKS OF DEATH, BODILY INJURIES, OR PROPERTY DAMAGE ARISING OUT OF OR RELATED TO THE USE OF LINX TECHNOLOGIES RF PRODUCTS, INCLUDING WITH RESPECT TO ANY SERVICES PROVIDED BY LINX RELATED TO THE USE OF LINX TECHNOLOGIES RF PRODUCTS. LINX TECHNOLOGIES SHALL NOT BE LIABLE UNDER ANY CIRCUMSTANCES FOR A CUSTOMER'S, USER'S, OR OTHER PERSON'S DEATH, BODILY INJURY, OR PROPERTY DAMAGE ARISING OUT OF OR RELATED TO THE DESIGN OR USE OF A REMOTE CONTROL SYSTEM OR DEVICE EMPLOYING LINX TECHNOLOGIES RF PRODUCTS.

The limitations on Linx Technologies' liability are applicable to any and all claims or theories of recovery asserted by Customer, including, without limitation, breach of contract, breach of warranty, strict liability, or negligence. Customer assumes all liability (including, without limitation, liability for injury to person or property, economic loss, or business interruption) for all claims, including claims from third parties, arising from the use of the Products. Under no conditions will Linx Technologies be responsible for losses arising from the use or failure of the device in any application, other than the repair, replacement, or refund limited to the original product purchase price. Devices described in this publication may contain proprietary, patented, or copyrighted techniques, components, or materials.