

REV	DATE	DESCRIPTION	APPROVAL	REF:
0	23-JUN-99	ORIGINAL RELEASE		EC9925-02
A	7-MAR-03	REMOVE: *PLASTIC OR ABS UL94V-0* FROM NOTE.		

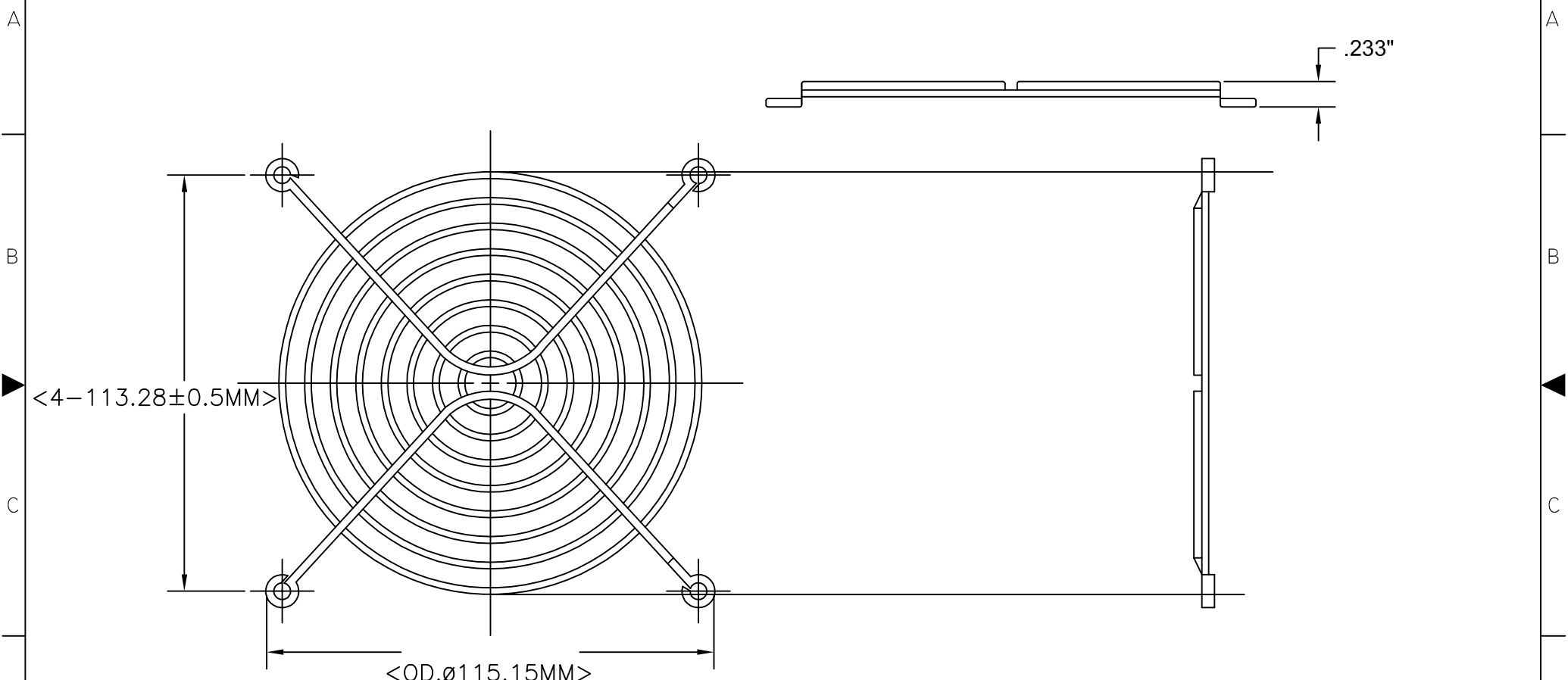

MAT'L:  
 WIRE, STEEL C1008 ELECTROPLATED BRIGHT NICKEL CHROME, CLEAR ZINC, ELECTRO  
 DEPOSIT. PLATING THICKNESS = .0005" MIN.

WELD JOINTS TO WITHSTAND MIN. 70LBS. SEPARATION FORCE TO MEET UL/CSA  
 STANDARDS. CONFORMS TO U.L.Ø1/4" PLUG GAGE TEST

UNLESS NOTED:  
 TOLERANCES SHALL BE  
 .X = 0.300  
 .XX = 0.150  
 .XXX = 0.075  
 ANGULAR = 0.200

THIS DRAWING IS THE PROPERTY OF  
 SANYO DENKI AMERICA, INC. AND SHALL  
 BE DEEMED AS PROPRIETARY  
 INFORMATION. USE OF ANY INFORMATION  
 CONTAINED HEREIN SHALL BE PROHIBITED  
 WITHOUT WRITTEN PERMISSION OF SANYO  
 DENKI AMERICA, INC.

<b>SANYO DENKI AMERICA</b>	
<b>TORRANCE, CALIFORNIA</b>	
DWG NO: KM-127	
SCALE: NONE	REV: A
DRAWN BY: <del>TY</del>	DATE: 17-MAR-03
APPROVED: TY	DATE: 17-MAR-03
APPROVED:	DATE: