

MS2207

**RF & MICROWAVE TRANSISTORS
L-BAND AVIONICS APPLICATIONS**

Features

- 1090 MHz
- 50 VOLTS
- 15:1 VSWR CAPABILITY
- INPUT / OUTPUT MATCHING
- P_{OUT} = 400 WATTS
- G_P = 8.0 dB MINIMUM
- COMMON BASE CONFIGURATION

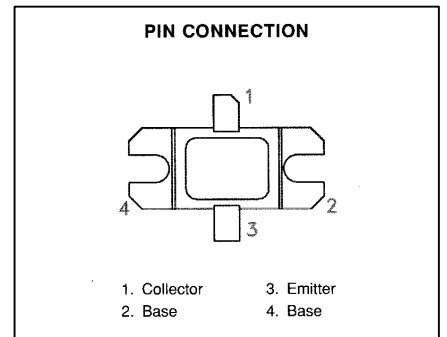
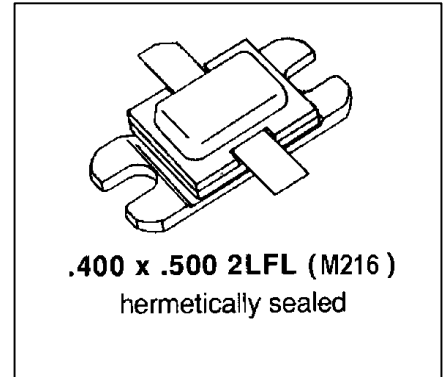

DESCRIPTION:

The MS2207 is a high power NPN bipolar transistor specifically designed for TCAS and Mode-S driver applications. This device is designed for operation under moderate pulse width and duty cycle pulse conditions and is capable of withstanding 15:1 output VSWR at rated conditions.

ABSOLUTE MAXIMUM RATINGS (T_{case} = 25°C)

Symbol	Parameter	Value	Unit
P _{DISS}	Power Dissipation	880	W
I _C	Device Current	24	A
V _{CC}	Collector Supply Voltage	55	V
T _J	Junction Temperature	250	°C
T _{STG}	Storage Temperature	-65 to +200	°C

Thermal Data

R _{TH(J-C)}	Junction-case Thermal Resistance	0.17	°C/W
----------------------	----------------------------------	------	------

ELECTRICAL SPECIFICATIONS (T_{case} = 25 °C)
STATIC

Symbol	Test Conditions		Value			Unit
			Min.	Typ.	Max.	
BV_{CBO}	I_C = 50 mA	I_E = 0 mA	65	---	---	V
BV_{EBO}	I_E = 15 mA	I_C = 0 mA	3.5	---	---	V
BV_{CER}	I_C = 50 mA	R_{BE} = 10Ω	65	---	---	V
I_{CES}	V_{BE} = 50 V	V_{CE} = 0 V	---	---	30	mA
h_{FE}	V_{CE} = 5 V	I_C = 5 A	10	---	---	---

DYNAMIC

Symbol	Test Conditions			Value			Unit
				Min.	Typ.	Max.	
P_{OUT}	f = 1090 MHz	P_{IN} = 63W	V_{CC} = 50V	400	---	---	W
η_C	f = 1090 MHz	P_{IN} = 63W	V_{CC} = 50V	45	---	---	%
G_p	f = 1090 MHz	P_{IN} = 63W	V_{CC} = 50V	8.0	---	---	dB

Conditions: Pulse Width = 32μS Duty Cycle = 2%

IMPEDANCE DATA

FREQ	Z _{IN} (Ω)	Z _{CL} (Ω)
1025 MHz	2.4 + j 3.2	1.4 - j 2.2
1090 MHz	3.8 + j 2.5	1.6 - j 1.6
1150 MHz	2.3 + j 1.3	1.2 - j 1.1

P_{IN} = 63 W

V_{CC} = 50 V

TYPICAL PERFORMANCE

**TYPICAL NARROWBAND
POWER AMPLIFIER**

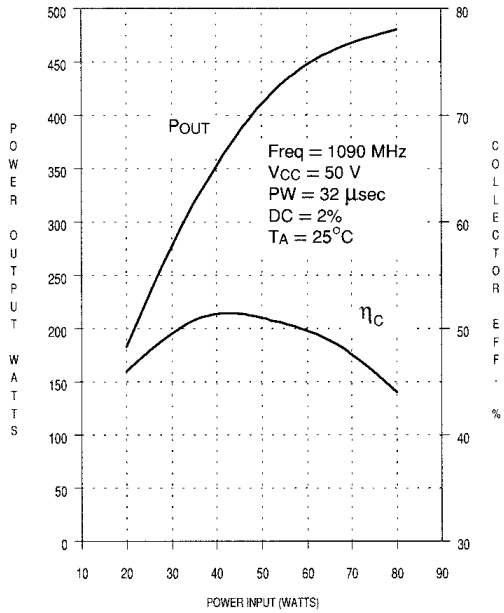

**TYPICAL RELATIVE OUTPUT
POWER & COLLECTOR EFFICIENCY
vs COLLECTOR VOLTAGE**

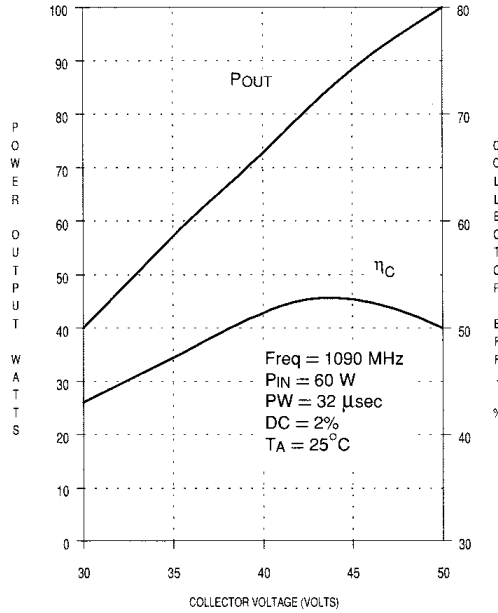

MAXIMUM THERMAL RESISTANCE vs PULSE WIDTH & DUTY CYCLE

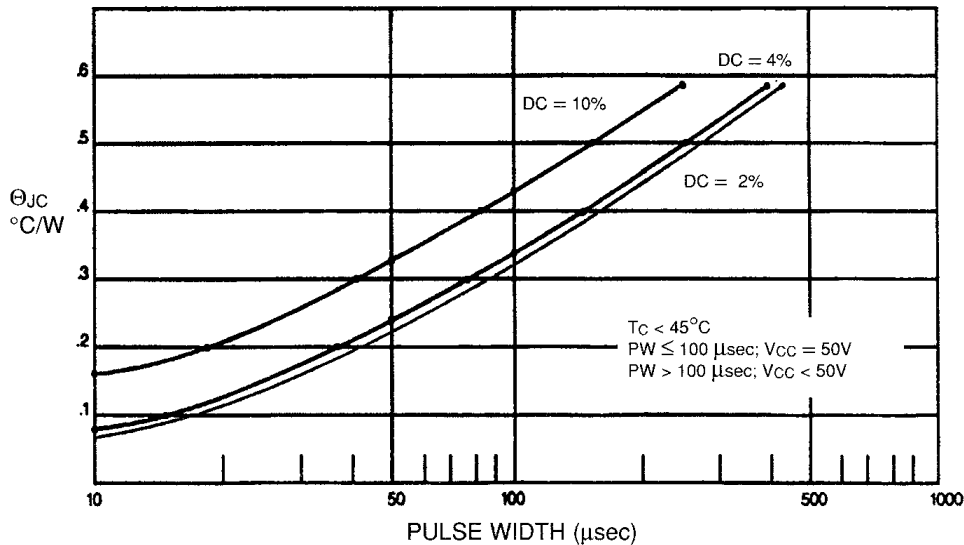

MS2207

TEST CIRCUIT

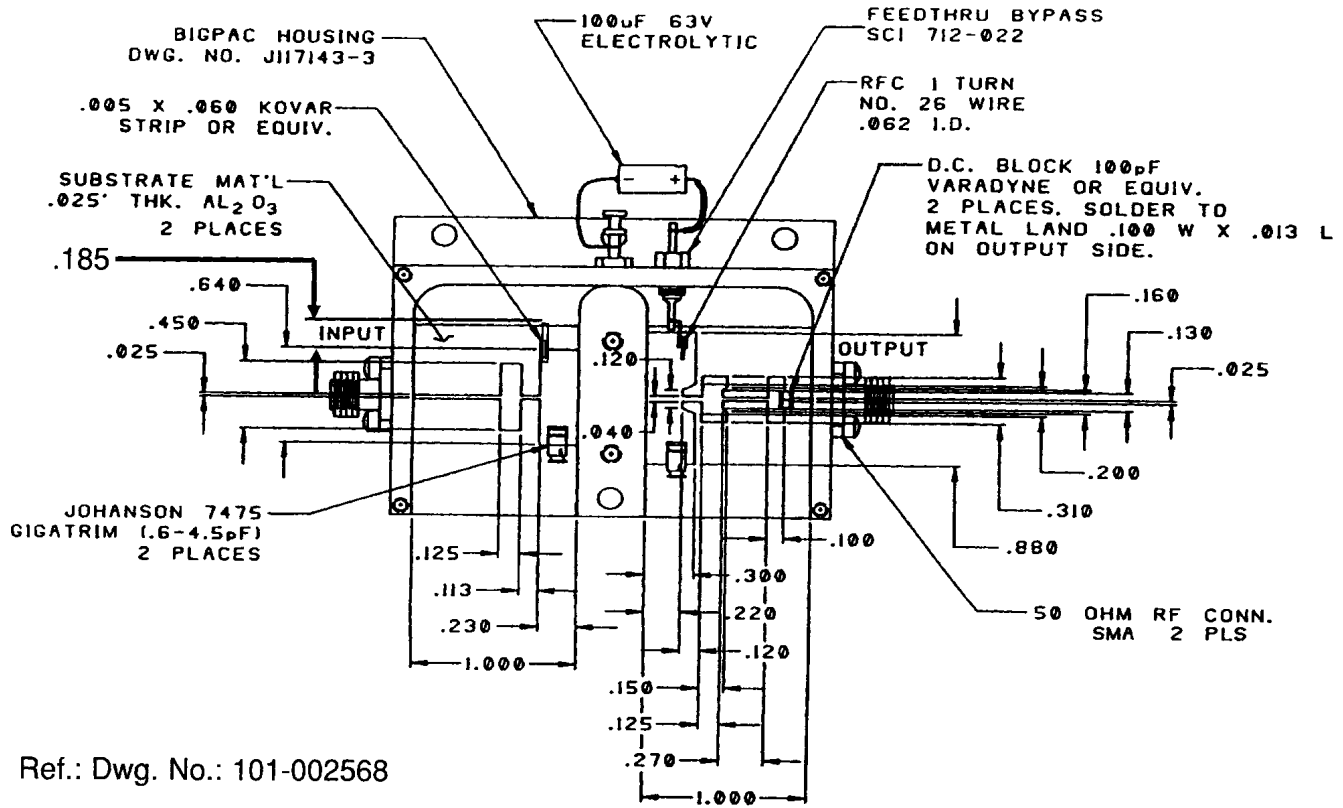

Ref.: Dwg. No.: 101-002568

PACKAGE MECHANICAL DATA

PACKAGE STYLE M216

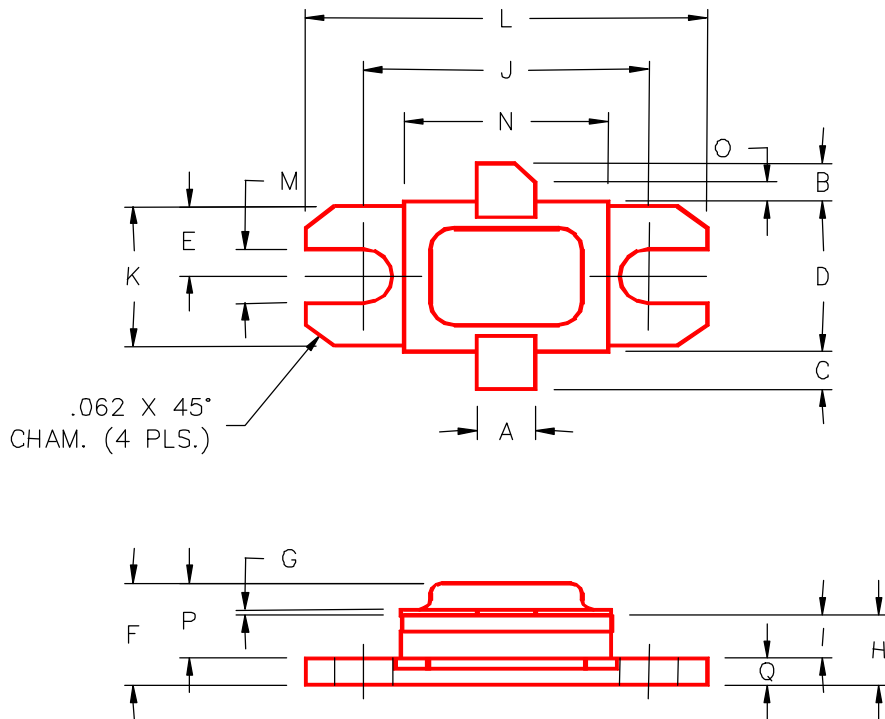

	MINIMUM INCHES/MM	MAXIMUM INCHES/MM		MINIMUM INCHES/MM	MAXIMUM INCHES/MM
A	.140/3,56		J	.700/17,78	
B	.110/2,80		K	.386/9,80	
C	.110/2,80		L	.900/22,86	
D	.395/10,03	.407/10,34	M	.120/3,05	
E	.193/4,90		N	.500/12,70	
F		.230/5,84	O	.050/1,27	
G	.003/0,08	.006/0,15	P		.170/4,32
H	.118/3,00	.131/3,33	Q	.062/1,58	
I	.063/1,60				