

MATERIAL AND FINISH

Insulator: Polycarbonate or Thermoplastic, black, UL-94V-0 rated.
Solder Terminals: Brass, Tin plated.

ELECTRICAL SPECIFICATIONS:

Rated current: 10A
Rated voltage: 250VAC



Rated current: 20A
Rated voltage: 250VAC



No of Port	L	E	F
2	51.2	48.0	48.3
3	75.4	72.0	72.2
4	99.6	96.0	96.2
5	123.2	120.0	120.3
6	147.2	144.0	144.4
7	171.2	168.0	168.4

ORDERING CODE:

44R02- 131 - 1 2

1) NO OF PORT (SEE CHART ABOVE)

2) PANEL THICKNESS

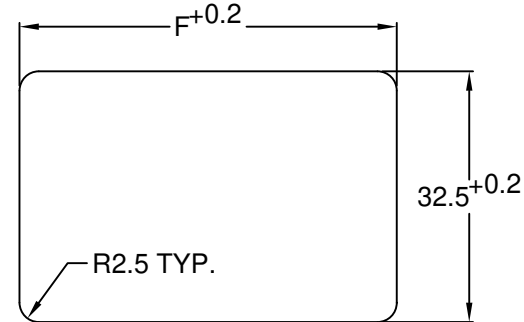
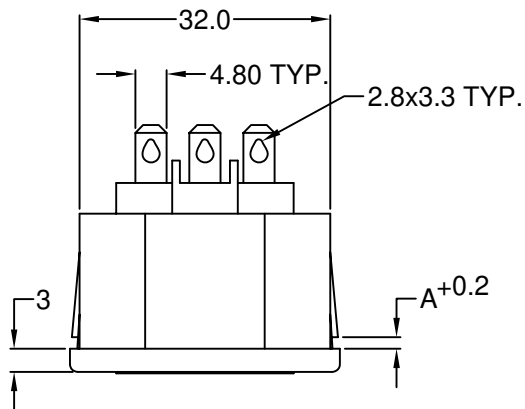

RECOMMENDED PANEL CUTOUT

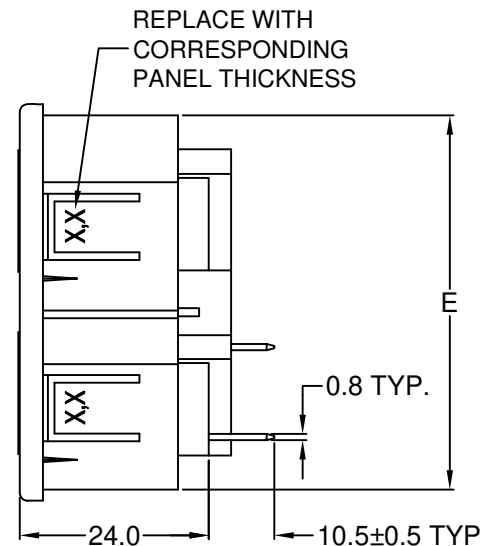
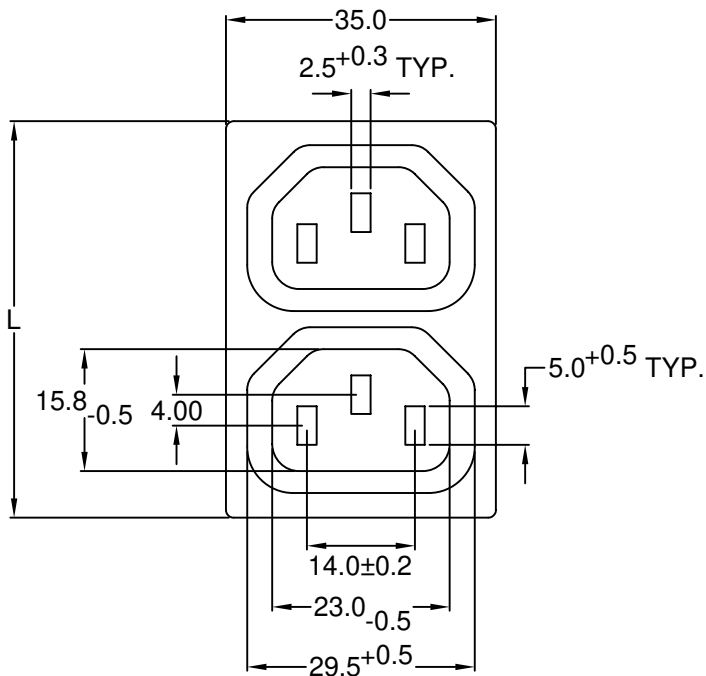

REV	DATE	CHANGE	CHNG CHECK APPR		
			CHNG	CHK	APPR
A	2/28/03	CHNG UL RATING TO 20A	PB	TD	PB
B	5/14/04	REV'D DIM L, E, F	TD	PB	PB
C	1/24/05	CHNG DIM E & F FOR 3 & 4 PORTS	PB	DF	PB
D	1/30/08	ADD 1.0mm PANEL THICKNESS	PB		

P/N	A	MAX. PANEL THICKNESS
44R02-X131-100	1.0	1.0
44R02-X131-150	1.5	1.5
44R02-X131-250	2.5	2.5

ADDITIONAL PANEL THICKNESS AVAILABLE ON REQUEST

TOLERANCE UNLESS OTHERWISE SPECIFIED
 X ± 1
 X.X ± 0.4
 X.XX ± 0.20

DRAWN BY	DT	DATE:	1/15/03
CHECK BY	PB	DATE:	1/15/03
APPR BY		DATE:	

RoHS COMPLIANT

Power Dynamics, Inc.
 Phone: 973 560-0019 Whippary, New Jersey Fax: 973 560-0076

PART: IEC 60320 C13 STRIP APPL. OUTLET;
 SNAP-IN, 4.8 Q.C. TERMINAL

44R02-X131-XXX

PART #: 44R02-X131-XXX SHEET 1 of 1

SIZE: A ALL DIMENSIONS FOR REFERENCE ONLY
 SCALE: NTS DIMENSIONS ARE IN MILLIMETERS REV: D