

GENERAL DESCRIPTION

The SP6699 is an inductor-based DC/DC converter designed to drive up to six white LEDs in series for LCD modules and keypad backlighting functions.

Only one feedback resistor is needed to control the LED current and obtain the desired brightness. A 1.2MHz constant frequency PWM control scheme is used, enabling the usage of small external components. A typical application needs a 1mm tall inductor and a 0.22 μ F output capacitor. Additionally, the boost circuit Schottky diode is integrated, further reducing the overall foot print.

A logic controlled enable pin allows this device to be placed in a low current consumption mode of a few microamps. Furthermore, the SP6699 is equipped with an over voltage output protection circuit which clamps the output voltage to 30 volts when any LED fails or in other abnormal conditions.

The SP6699 is offered in a small lead free, RoHS compliant 6-pin SOT23 package.

APPLICATIONS

- **LCD Modules**
- **Keypad Backlighting**
- **Digital Cameras**
- **GPS Receivers**
- **Portable Media Players**

FEATURES

- **High Output Voltage: Up to 30V**
 - Drives 2 to 6 LEDs @ 20mA
 - High Efficiency up to 84%
- **Integrated Schottky Diode**
- **Fast 1.2MHz Switching Frequency**
- **200mV Feedback Voltage**
- **PWM Dimming Capability up to 2KHz**
- **Over Output Voltage Protection**
- **Internal Soft Start Circuit**
- **Small SOT23-6 Package**

TYPICAL APPLICATION DIAGRAM

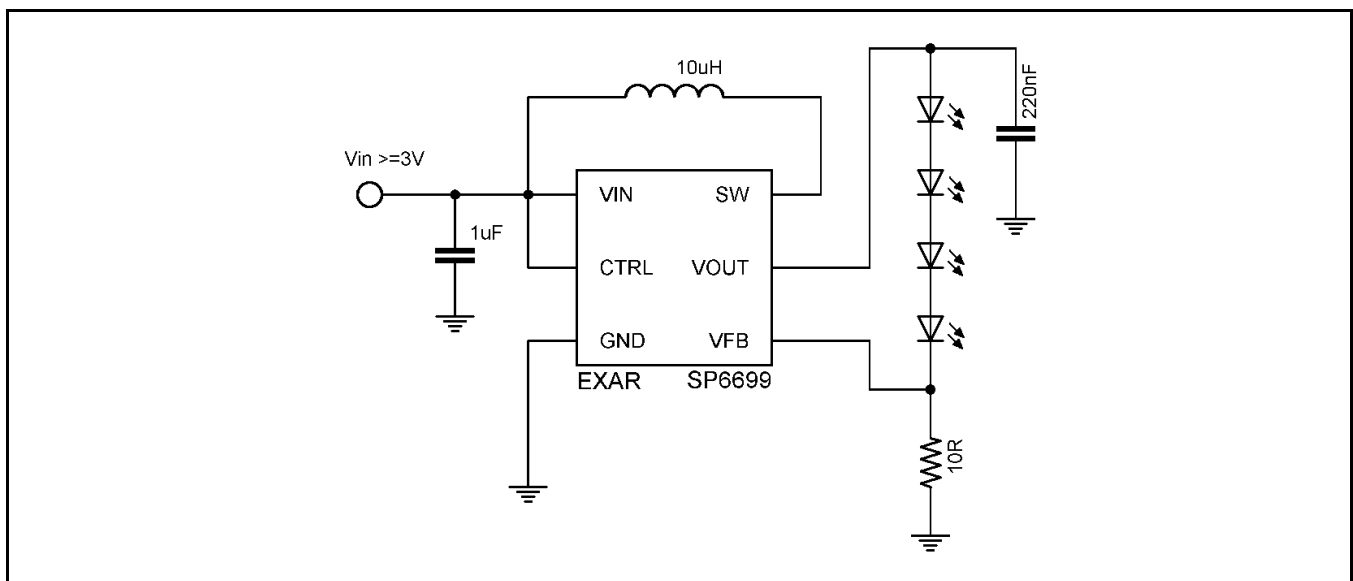

Fig. 1: SP6699 Application Diagram

ABSOLUTE MAXIMUM RATINGS

These are stress ratings only and functional operation of the device at these ratings or any other above those indicated in the operation sections of the specifications below is not implied. Exposure to absolute maximum rating conditions for extended periods of time may affect reliability.

| | |
|---|----------------|
| Input Voltage V_{IN} | 20V |
| SW Voltage..... | 38V |
| FB Voltage..... | 20V |
| CTRL Voltage | 20V |
| Operating Junction Temperature..... | 150°C |
| Storage Temp. Range T_{STG} | -65°C to 150°C |
| Lead Temperature (sold. 10s) T_{LEAD} | 260°C |
| ESD Ratings – Human Body Model..... | 2000V |
| ESD Ratings – Machine Model | 250V |
| Moisture Sensitivity Level (MSL)..... | 3 |

OPERATING RATINGS

| | |
|--|---------------|
| Input Voltage Range V_{IN} | 2.7V to 16V |
| Operating Temperature Range..... | -40°C to 85°C |
| CTRL Voltage V_{CTRL} | 16V |
| Thermal Resistance (Junction to Ambient) $R_{\theta JA}$ | 265°C/W |
| Thermal Resistance (Junction to case) $R_{\theta JC}$ | 60°C/W |

ELECTRICAL SPECIFICATIONS

Specifications with standard type are for an Operating Junction Temperature of $T_A = 25^\circ\text{C}$ only; limits applying over the full Operating Junction Temperature range are denoted by a “•”. Minimum and Maximum limits are guaranteed through test, design, or statistical correlation. Typical values represent the most likely parametric norm at $T_A = 25^\circ\text{C}$, and are provided for reference purposes only. Unless otherwise indicated, $V_{IN} = 3\text{V}$, $V_{CTRL} = 3\text{V}$, $T_A = 25^\circ\text{C}$.

| Parameter | Min. | Typ. | Max. | Units | Conditions |
|--|------|------|------|---------------|-----------------------------------|
| Operating Voltage | 2.5 | | 16 | V | |
| Feedback Voltage V_{FB} | 188 | 200 | 212 | mV | • $I_{OUT}=20\text{mA}$, 4 LEDs |
| FB Pin Bias Current I_{FB} | | 35 | 100 | nA | |
| Supply Current I_{CC} | 1.5 | 2.5 | 3.2 | mA | $V_{FB} = V_{IN}$, not switching |
| Supply Current I_Q | 2.0 | 4.0 | 6.0 | μA | $V_{CTRL} = 0\text{V}$ |
| Switching Frequency f | 0.9 | 1.2 | 1.5 | MHz | |
| Maximum Duty Cycle D_{MAX} | 90 | 93 | | % | |
| Switch Current Limit I_{LIMIT} | | 550 | | mA | $T_A=25^\circ\text{C}$, $D=40\%$ |
| | | 550 | | mA | $T_A=25^\circ\text{C}$, $D=80\%$ |
| Switch V_{CE} Saturation Voltage V_{CESAT} | | 360 | | mV | $I_{SW}=250\text{mA}$ |
| Switch Leakage Current | | 0.01 | 5 | μA | $V_{SW}=5\text{V}$ |
| CTRL Pin Voltage V_{CTRL} - High | 1.8 | | | V | |
| CTRL Pin Voltage V_{CTRL} - Low | | | 0.5 | V | |
| CTRL Bias Current I_{CTRL} | | 100 | | μA | |
| Schottky Forward Drop V_{DROP} | | 0.7 | | V | $I_D=150\text{mA}$ |
| OVP Trip Point | | 30 | | V | |
| Schottky Leakage Current | | 0.1 | 4 | μA | $V_R=23\text{V}$ |
| | | | 150 | μA | $V_R=27\text{V}$ |
| Soft Start Time t | | 300 | | μs | |

BLOCK DIAGRAM

Fig. 2: SP6699 Block Diagram

PIN ASSIGNMENT

Fig. 3: SP6699 Pin Assignment

PIN DESCRIPTION

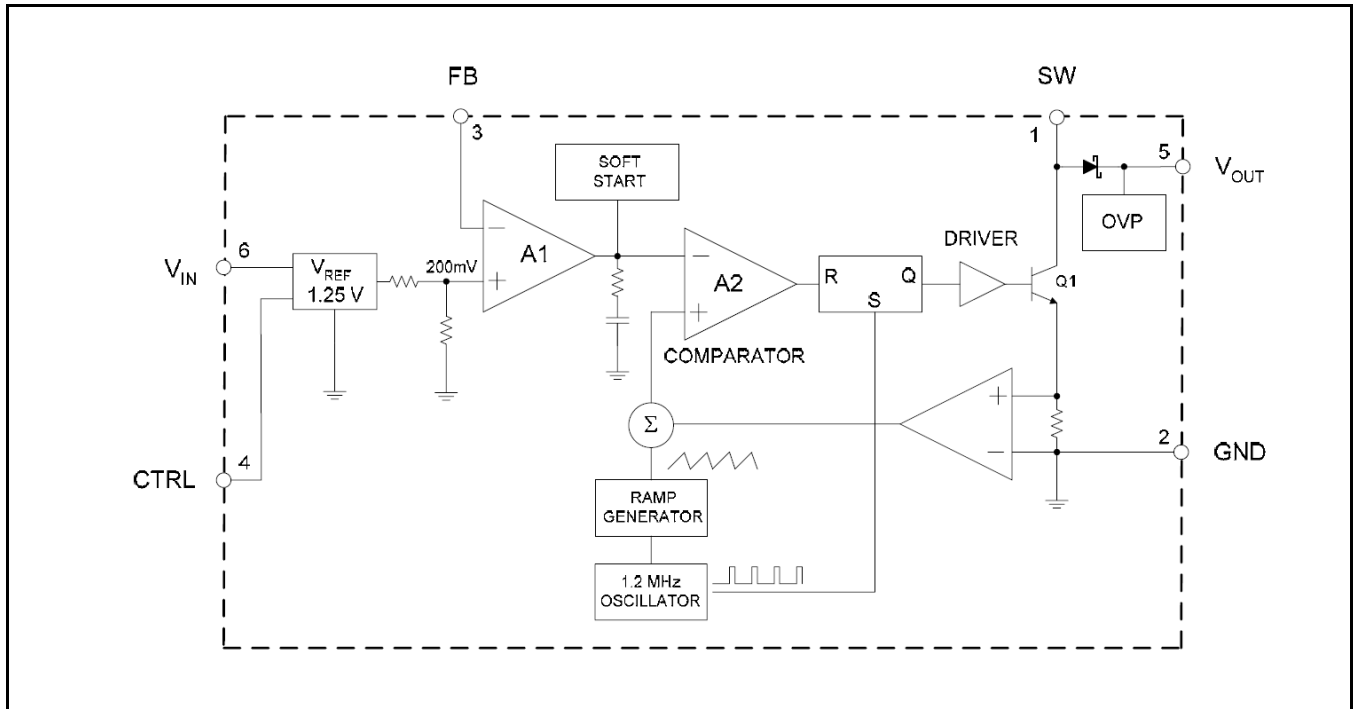
| Name | Pin Number | Description |
|------|------------|---|
| SW | 1 | Switch pin. Connect external inductor |
| GND | 2 | Ground signal pin |
| FB | 3 | Voltage Feedback. Reference voltage is 200mV |
| CTRL | 4 | Shutdown and dimming pin. Connect to 1.8V or higher to enable device; Connect to 0.5V or less to disable device; Connect to a PWM signal of 2kHz or less to achieve LEDs brightness dimming |
| VOUT | 5 | Output pin. Connected to the cathode of the internal Schottky diode. |
| VIN | 6 | Input supply pin. Must be locally bypassed. |

ORDERING INFORMATION⁽¹⁾

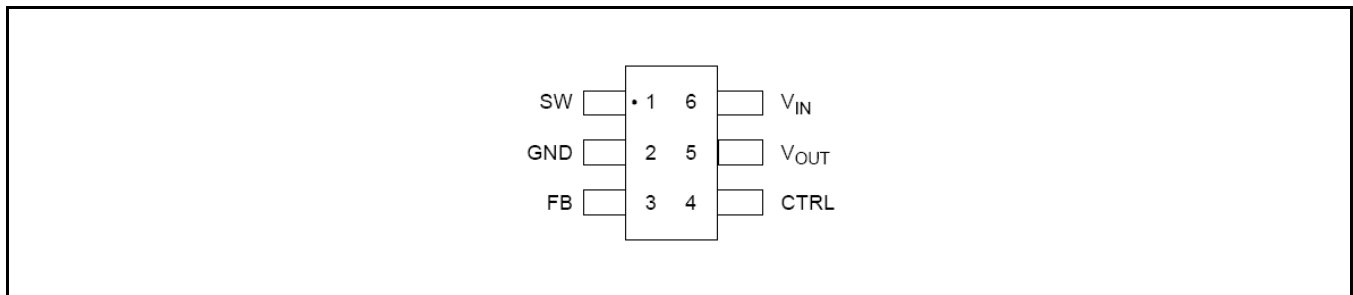
| Part Number | Temperature Range | Package | Packing Method | Lead Free ⁽²⁾ |
|---------------|--------------------------------|----------|----------------|--------------------------|
| SP6699EK-L/TR | -40°C ≤ T _A ≤ +85°C | SOT-23-6 | Tape & Reel | Yes |
| SP6699EB | SP6699 Evaluation Board | | | |

Notes:

1. Refer to www.maxlinear.com/SP6699 for most up-to-date Ordering Information.
2. Visit www.maxlinear.com for additional information on Environmental Rating.

Note that the SP6699 series is packaged in Tape and Reel with a reverse part orientation as per the following diagram

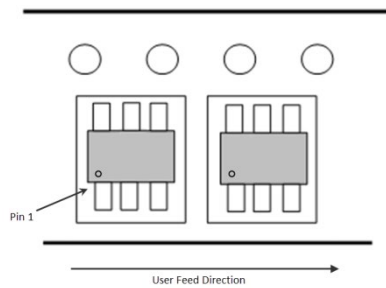

TYPICAL PERFORMANCE CHARACTERISTICS

All data taken at $V_{IN} = 3.6V$, $EN = V_{IN}$, $R_{SET} = 24k\Omega$, $T_A = 25^\circ C$, unless otherwise specified - Schematic and BOM from Application Information section of this datasheet.

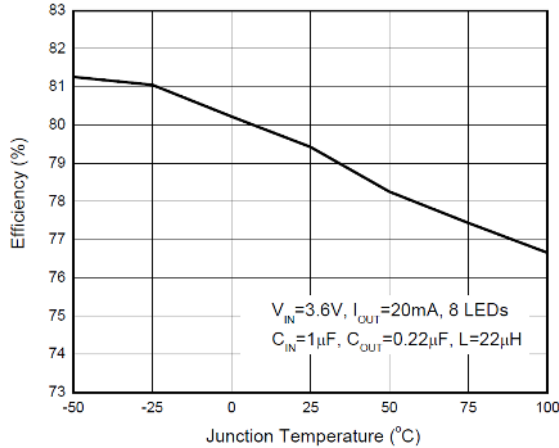

Fig. 4: Efficiency vs. Junction Temperature

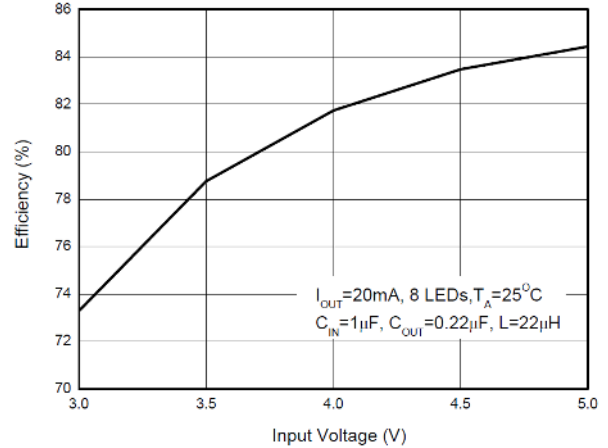

Fig. 5: Efficiency vs. Input Voltage

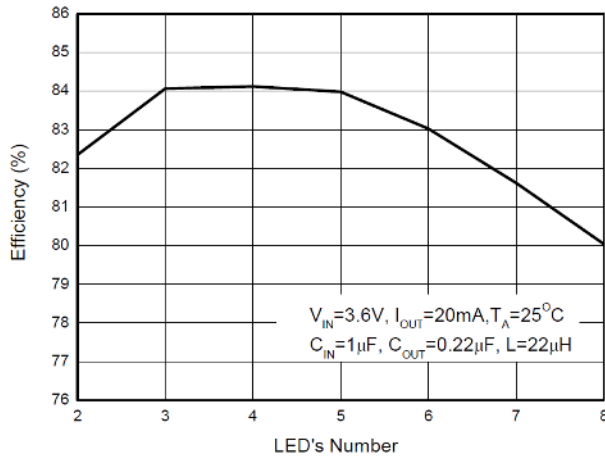

Fig. 6: Efficiency vs. Number of LEDs

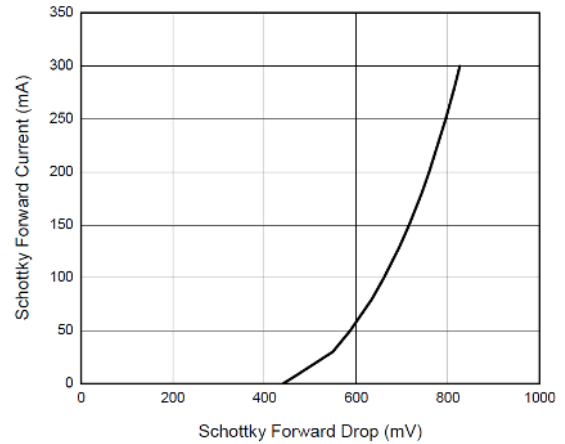

Fig. 7: Schottky Forward Current vs Schottky Forward Drop

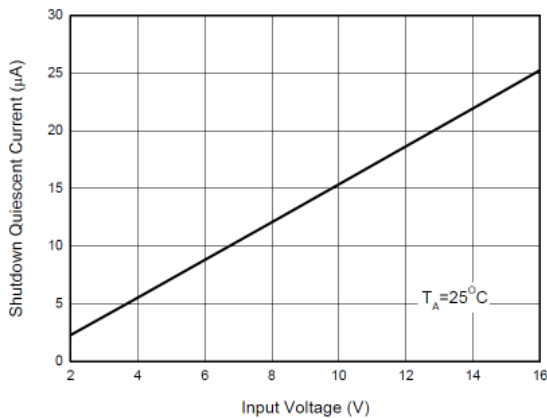

Fig. 8: Shutdown Quiescent Current vs Input Voltage

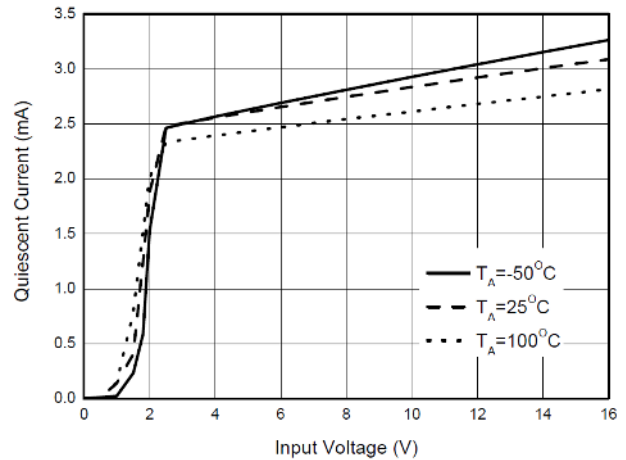

Fig. 9: Supply Current vs Input Voltage

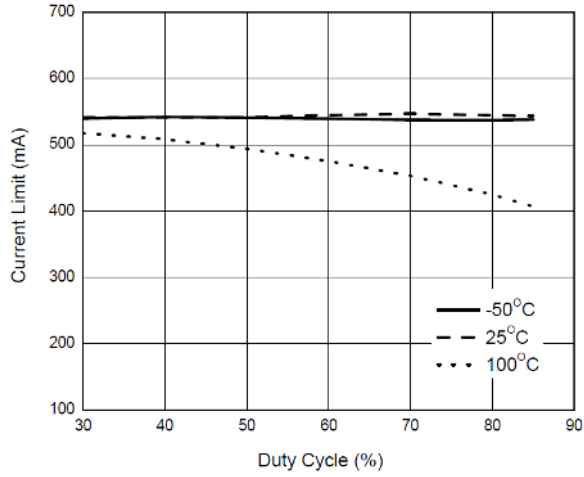

Fig. 10: Current Limit vs. Duty Cycle

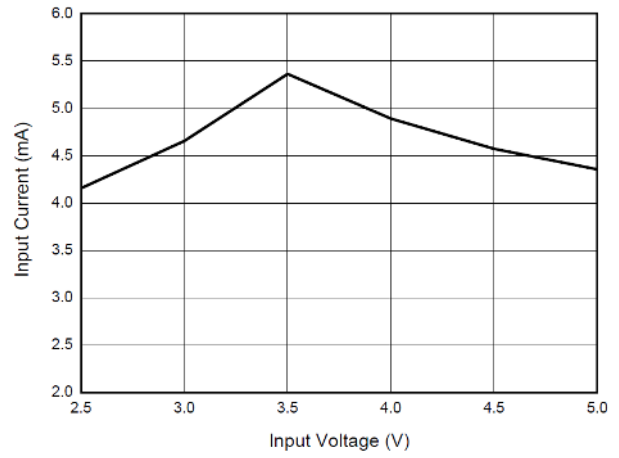

Fig. 11: Input Current in Output Open Circuit vs Input Voltage

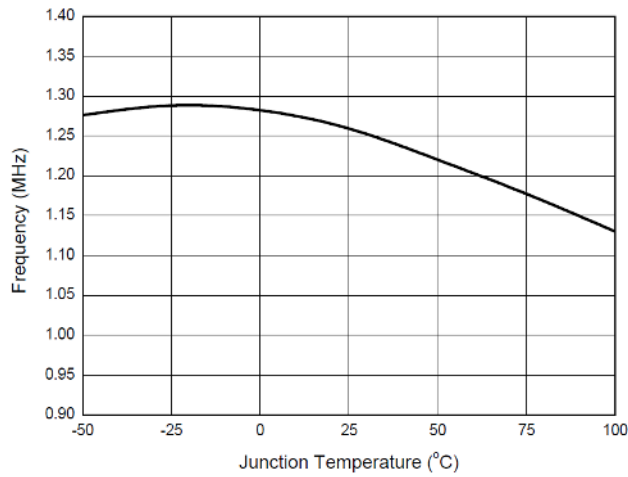

Fig. 12: Switching Frequency vs Junction Temperature

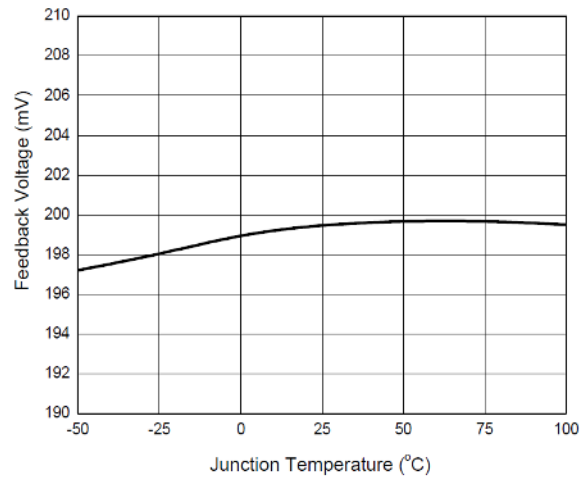

Fig. 13: Feedback Voltage vs Junction Temperature

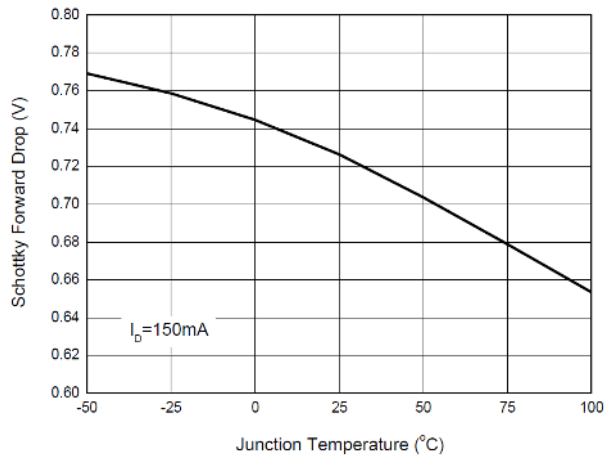

Fig. 14: Schottky Forward Drop vs Junction Temperature

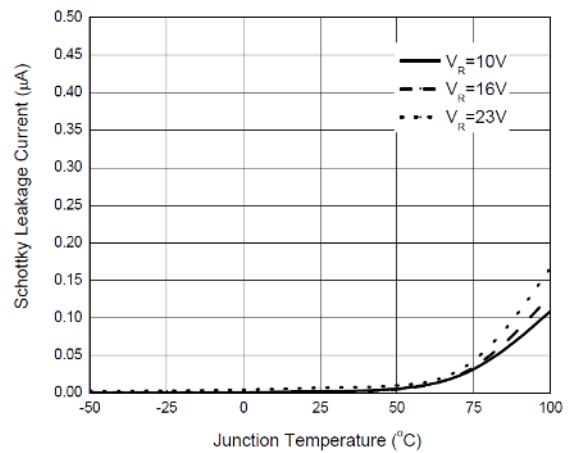

Fig. 15: Schottky Leakage Current vs Junction Temperature

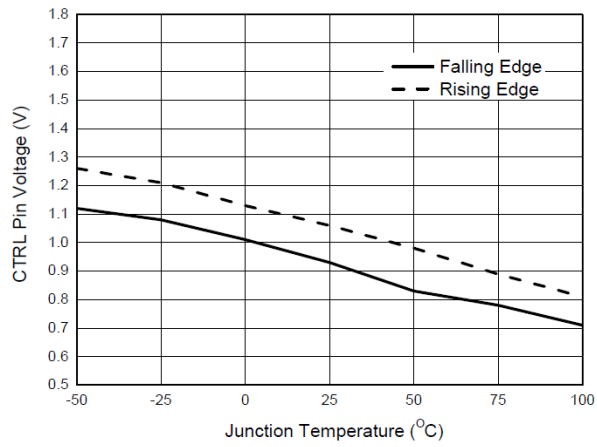

Fig. 16: CTRL Pin Voltage vs. Junction Temperature

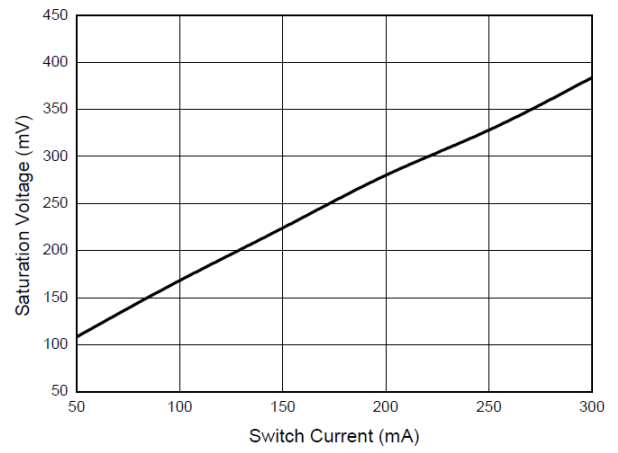

Fig. 17: Switch Saturation Current vs Switch Current

THEORY OF OPERATION

DETAILED DESCRIPTION

The SP6699 is a boost DC-DC converter which uses a constant frequency, current mode control scheme to provide excellent line and load regulation. Operation can be best understood by referring to the Figure 1 on the first page or Figure 18 below. At the start of each oscillator cycle, the SR latch is set and the switch Q1 turns on. The switch current will increase linearly. The voltage on sense resistor is proportional to the switch current. The output of the current sense amplifier is added to a stabilizing ramp and the result is fed into the non-inversion input of the PWM comparator A2. When this voltage exceeds the output voltage level of the error amplifier A1, the SR latch is reset and the switch is turned off. It is clear that the voltage level at non-inversion input of A2 sets the peak current level to keep the output in regulation. This voltage level is the output signal of error amplifier A1, and is the amplified signal of the voltage difference between feedback voltage and reference voltage of 200mV. So, a constant output current can be provided by this operation mode.

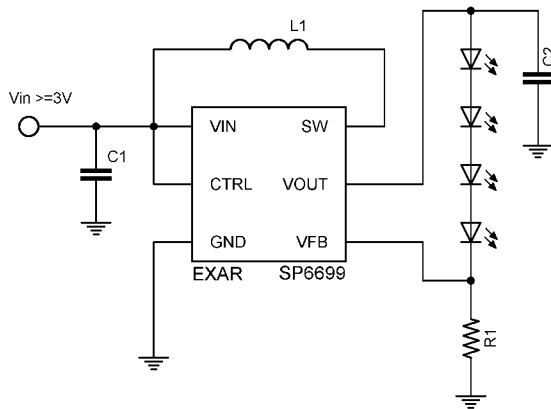

Fig. 18: R1 Selection Typical Application Circuit

LED CURRENT CONTROL

Refer to Figure 18; the LED current is controlled by the feedback resistor R1. LEDs' current accuracy is determined by the regulator's feedback threshold accuracy and is independent of the LED's forward voltage variation. So the precise resistors are preferred. The resistance of R1 is in inverse proportion to the LED current since the feedback reference is fixed at 200mV. The relation for R1 and LED current can be expressed as below:

$$R1 = 200\text{mV} / I_{LED}$$

OVER VOLTAGE PROTECTION

The SP6699 has an internal open-circuit protection circuit. When the LEDs are disconnected from the circuit or fail open, the output voltage is clamped at 30V. The SP6699 will switch at a low frequency, and minimize input current.

SOFT START

The SP6699 has an internal soft start circuit to limit the inrush current during startup. The startup delay is controlled by internal soft start capacitor. Please refer to Figure 19.

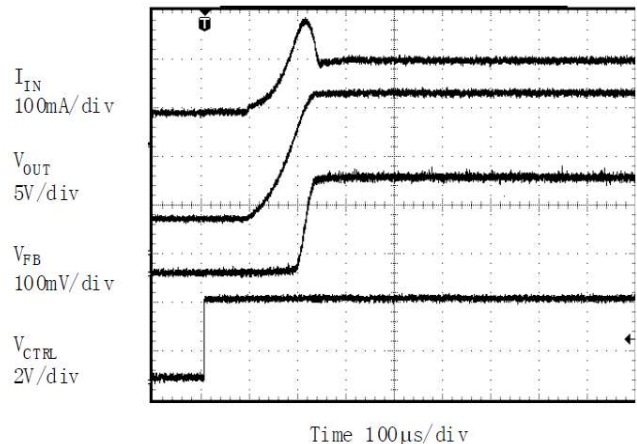

Fig. 19: Soft Start Waveform
 $V_{IN} = 3.6\text{V}$, 5 LEDs, $I_{LED} = 20\text{mA}$

DIMMING CONTROL

Two typical types of dimming control circuit are present. First, is providing a PWM input into the CTRL Pin. This is typically preferred in that this will result in constant color from the LED while changing the brightness. Second, changing the feedback voltage to get appropriate duty and luminous intensity is also possible.

Adding a control signal to CTRL pin

First, adding a PWM Signal to the CTRL pin directly. The SP6699 is turned on or off by the PWM signal when it is applied on the CTRL pin. The typical frequency of this PWM signal is 200Hz to 2KHz. Please refer to figure 20.

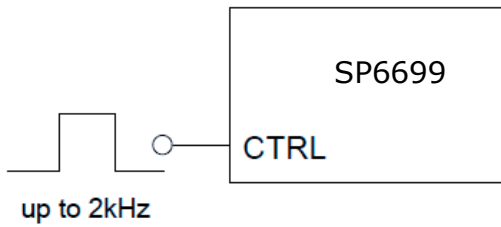

Fig. 20: Dimming Control using a PWM Signal on CTRL Pin

Changing the effective feedback voltage

There are three methods to change the effective feedback voltage.

First, adding a constant DC voltage through a resistor divider to FB pin can control the dimming. Changing the DC voltage or resistor between the FB Pin and the DC voltage can get appropriate luminous intensity. Comparing with all kinds of PWM signal control, this method features a stable output voltage and LEDs current. Please refer to figure 21.

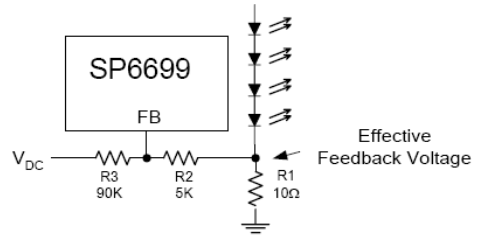

Fig. 21: Dimming Control using a DC Voltage

Second, using a filtered PWM signal can do it. The filtered PWM signal can be considered as a varying and adjustable DC voltage.

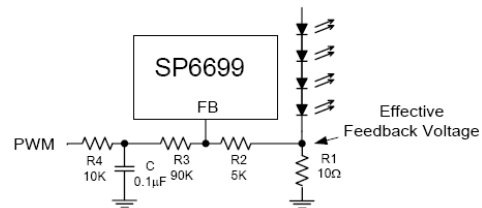

Fig. 22: Dimming Control using a Filtered PWM Voltage

Third, is using a logic signal to change the feedback voltage. For example, the FB pin is connected to the GND through a MOSFET and a resistor. And this MOSFET is controlled by a logic signal. The luminous intensity of LEDs will be changed when the MOSFET turns on or off.

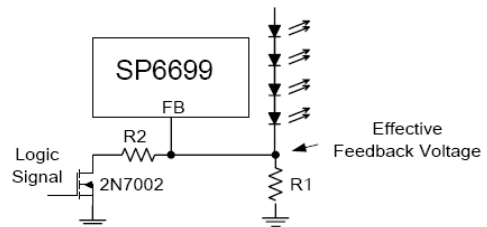
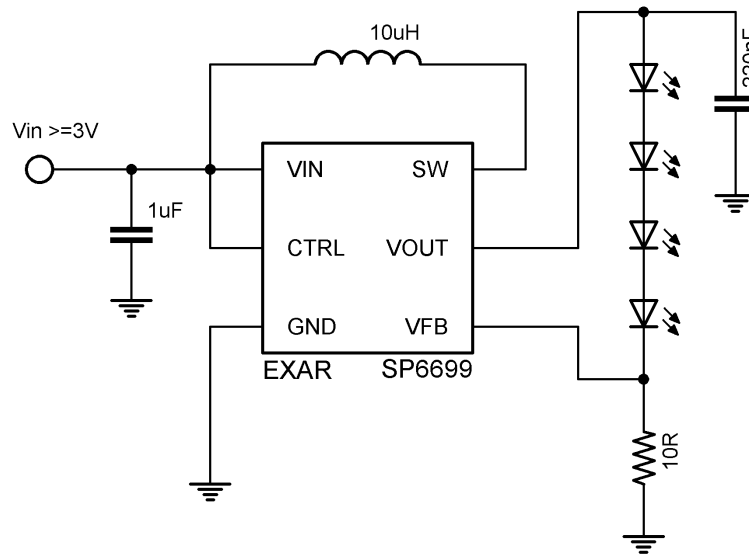

Fig. 23: Dimming Control using Logic Signal

TYPICAL APPLICATION CIRCUITS

4 White LEDs Driver



C: X5R or X7R Dielectric
 L: Sumida CDRH5D28R-100NC or equivalent
 For use over the full operating temperature range

5 (or 6) White LEDs Driver

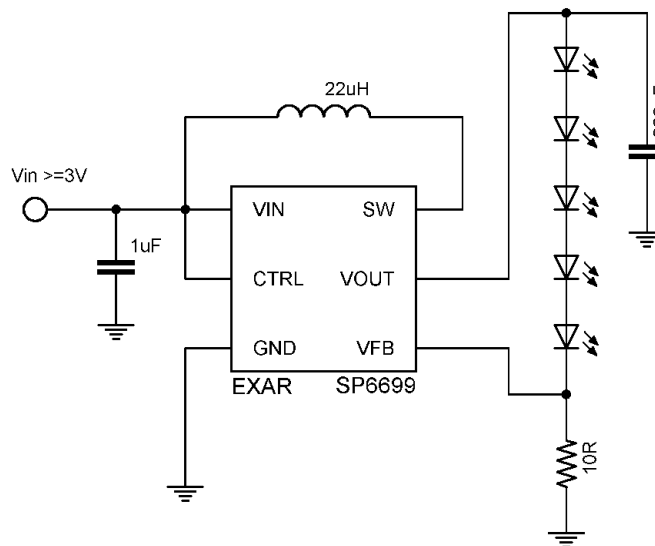

C: X5R or X7R Dielectric
 L: Sumida CDRH5D28R-220NC or equivalent
 For use over the full operating temperature range

PACKAGE SPECIFICATION

6-PIN SOT23

Unit: mm (inch)

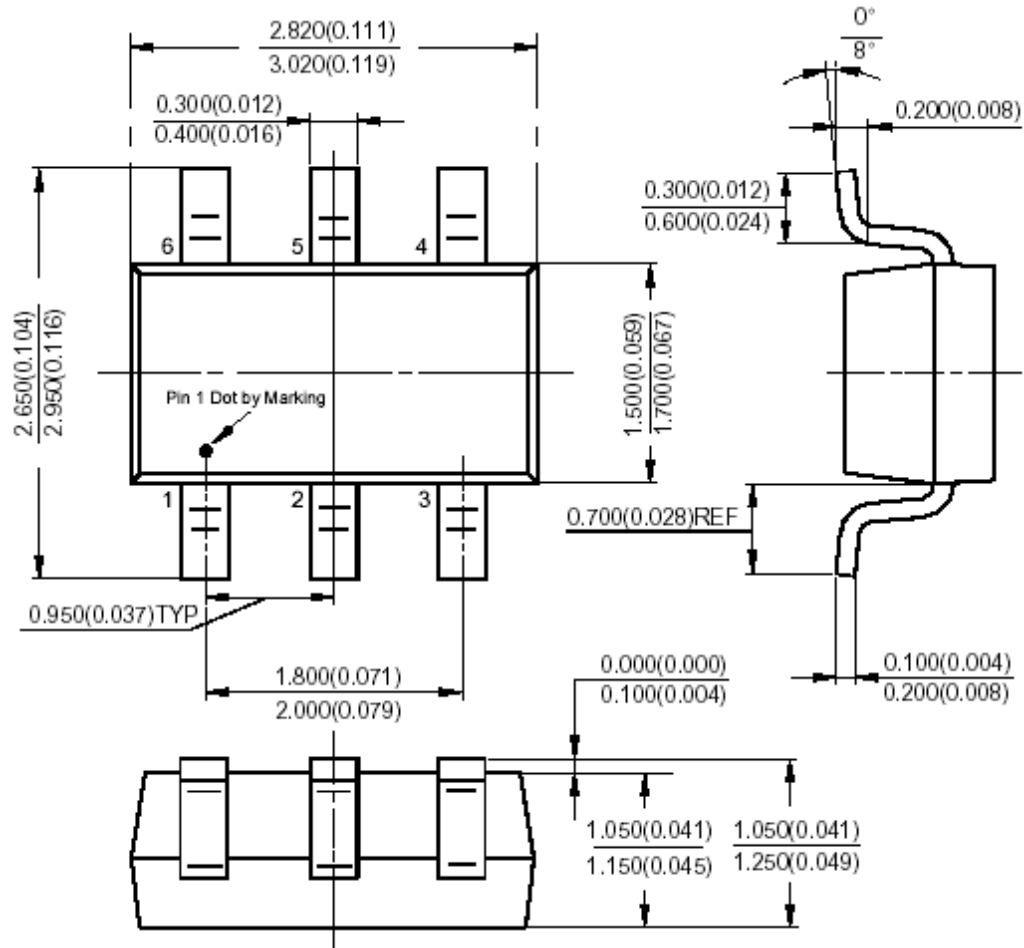



REVISION HISTORY

| Revision | Date | Description |
|----------|------------|---|
| E | 01/21/08 | Initial Data Sheet |
| 2.0.0 | 04/27/09 | Reformat of Datasheet Corrections of typographical errors |
| 2.1.0 | 10/01/2011 | Inclusion of Tape and Reel part orientation and MSL level information |
| 3.0.0 | 04/06/2014 | Eliminated analog dimming function on CTRL pin and improved logic level low compatibility for PWM inputs. Increase maximum switch voltage allowing more LEDs in series. Current limit now constant across duty cycle. Shutdown and non-switching Iq slightly changed. Nominal operating frequency increased to 1.2MHz. Reference voltage over temp improved. Recommended maximum PWM dimming frequency increased from 1kHz to 2kHz. |
| 3.0.1 | 01/24/2020 | Updated to MaxLinear logo. Updated Ordering Information. |



CORPORATE HEADQUARTERS:

5966 La Place Court
Suite 100
Carlsbad, CA 92008
Tel.: +1 (760) 692-0711
Fax: +1 (760) 444-8598
www.maxlinear.com

The content of this document is furnished for informational use only, is subject to change without notice, and should not be construed as a commitment by Maxlinear, Inc. Maxlinear, Inc. Assumes no responsibility or liability for any errors or inaccuracies that may appear in the informational content contained in this guide. Complying with all applicable copyright laws is the responsibility of the user. Without limiting the rights under copyright, no part of this document may be reproduced into, stored in, or introduced into a retrieval system, or transmitted in any form or by any means (electronic, mechanical, photocopying, recording, or otherwise), or for any purpose, without the express written permission of Maxlinear, Inc.

Maxlinear, Inc. Does not recommend the use of any of its products in life support applications where the failure or malfunction of the product can reasonably be expected to cause failure of the life support system or to significantly affect its safety or effectiveness. Products are not authorized for use in such applications unless Maxlinear, Inc. Receives, in writing, assurances to its satisfaction that: (a) the risk of injury or damage has been minimized; (b) the user assumes all such risks; (c) potential liability of Maxlinear, Inc. Is adequately protected under the circumstances.

Maxlinear, Inc. May have patents, patent applications, trademarks, copyrights, or other intellectual property rights covering subject matter in this document. Except as expressly provided in any written license agreement from Maxlinear, Inc., the furnishing of this document does not give you any license to these patents, trademarks, copyrights, or other intellectual property.

Maxlinear, the Maxlinear logo, and any Maxlinear trademarks, MxL, Full-Spectrum Capture, FSC, G.now, AirPHY and the Maxlinear logo are all on the products sold, are all trademarks of Maxlinear, Inc. or one of Maxlinear's subsidiaries in the U.S.A. and other countries. All rights reserved. Other company trademarks and product names appearing herein are the property of their respective owners.

© 2008 - 2020 Maxlinear, Inc. All rights reserved.