

## FEATURES

**DO-178C/DO-254 Design Assurance Level (DAL) B certification intent**

**ED-12C certification intent**

**Triaxial, digital gyroscope,  $\pm 450^\circ/\text{sec}$  dynamic range**

**$\pm 0.018^\circ$  axis-to-axis misalignment error**

**$6^\circ/\text{Hr}$  in-run bias stability**

**$0.3^\circ/\sqrt{\text{Hr}}$  angular random walk**

**$0.045^\circ/\text{sec}$  nonlinearity**

**Triaxial, digital accelerometer,  $\pm 5 g$  dynamic range**

**Triaxial, delta angle and delta velocity outputs**

**Factory calibrated sensitivity, bias, and axial alignment**

**Calibration temperature range:  $-40^\circ\text{C}$  to  $+85^\circ\text{C}$**

**Serial peripheral interface (SPI) compatible**

**Programmable operation and control**

**Automatic and manual bias correction controls**

**4 FIR filter banks, 120 configurable taps**

**Digital I/O: data ready alarm indicator, external clock**

**Alarms for condition monitoring**

**Power-down/sleep mode for power management**

**Optional external sample clock input: up to 2.4 kHz**

**Continuous self test of inertial sensors**

**On demand self test of inertial sensors**

**Continuous CRC-based memory testing**

**Single-supply operation: 3.0 V to 3.6 V**

**2000 g mechanical shock survivability**

**Operating temperature range:  $-40^\circ\text{C}$  to  $+105^\circ\text{C}$**

## APPLICATIONS

**Attitude and heading reference systems**

**Platform stabilization and control**

**Unmanned vehicle navigation**

**Robotics and instrumentation**

## GENERAL DESCRIPTION

The ADIS16487 is a complete inertial system that includes a triaxis gyroscope and a triaxis accelerometer. Each inertial sensor in the ADIS16487 combines industry leading iMEMS® technology with signal conditioning that optimizes dynamic performance. The factory calibration characterizes each sensor for sensitivity, bias, alignment, and linear acceleration (gyroscope bias). As a result, each sensor has its own dynamic compensation formulas that provide accurate sensor measurements.

The ADIS16487 provides a simple, cost effective method for integrating accurate, multi-axis inertial sensing into industrial systems, especially when compared with the complexity and investment associated with discrete designs. All necessary motion testing and calibration are part of the production process at the factory, greatly reducing system integration time. Tight orthogonal alignment simplifies inertial frame alignment in navigation systems. The SPI and register structure provide a simple interface for data collection and configuration control.

For interests requiring evidence of avionics or safety critical applicability, this device supports certification to DO-178C/DO-254 DAL B within systems, which have completed either U.S. Federal Aviation Administration (FAA) or European Aviation Safety Agency (EASA) audits, and can under specific commercial arrangements be supported by preassessment and audit acceptance artifacts.

The ADIS16487 uses the same footprint and connector system as the ADIS16375, ADIS16480, ADIS16485, and ADIS16488A, which greatly simplifies the upgrade process. The ADIS16487 is packaged in a module that is approximately 47 mm × 44 mm × 14 mm and includes a standard connector interface.

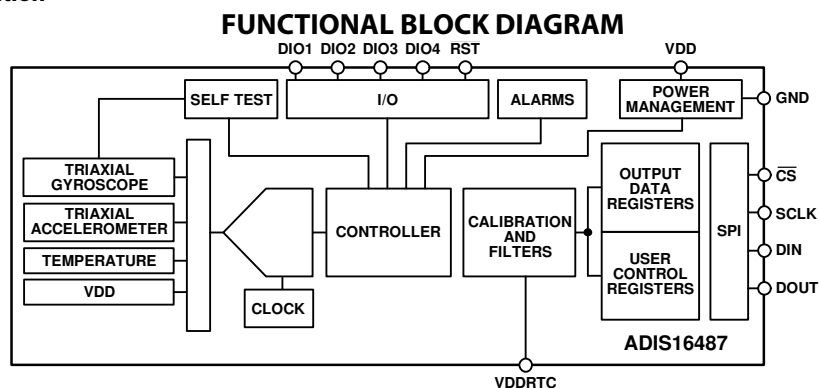

Figure 1.

For more information about the ADIS16487, contact the Analog Devices, Inc., [Customer Interaction Center](#) to connect with a technical support specialist.

Rev. SpB

[Document Feedback](#)

Information furnished by Analog Devices is believed to be accurate and reliable. However, no responsibility is assumed by Analog Devices for its use, nor for any infringements of patents or other rights of third parties that may result from its use. Specifications subject to change without notice. No license is granted by implication or otherwise under any patent or patent rights of Analog Devices. Trademarks and registered trademarks are the property of their respective owners.

One Technology Way, P.O. Box 9106, Norwood, MA 02062-9106, U.S.A.  
Tel: 781.329.4700 ©2018-2021 Analog Devices, Inc. All rights reserved.  
[Technical Support](#) [www.analog.com](http://www.analog.com)

**NOTES**