

DO NOT SCALE FROM THIS PRINT

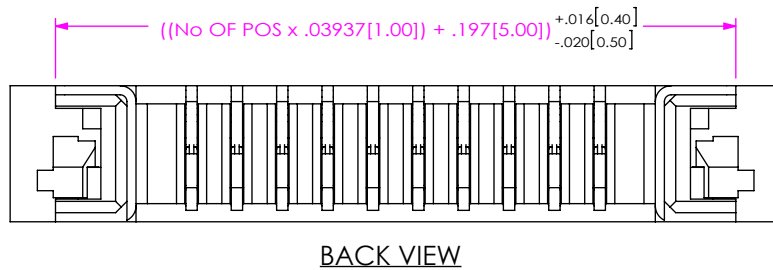

ZF1-XX-XX-XX-WT-XX

No OF POSITIONS

-04 THRU -30

LEAD STYLE

-01: CONTACT BOTTOM

-02: CONTACT TOP

\*-03: TOP ENTRY (SEE SHEET 3)

PACKAGING

BLANK: TUBES (SEE NOTE 7)

-TR: TAPE & REEL (SEE NOTES 8 & 9)

-FR: FULL REEL QTY TAPE & REEL (SEE NOTES 8 & 9)

WELD TAB

PLATING SPECIFICATION

-T: PURE TIN, MATTE FINISH

-TM: PURE TIN, MATTE FINISH

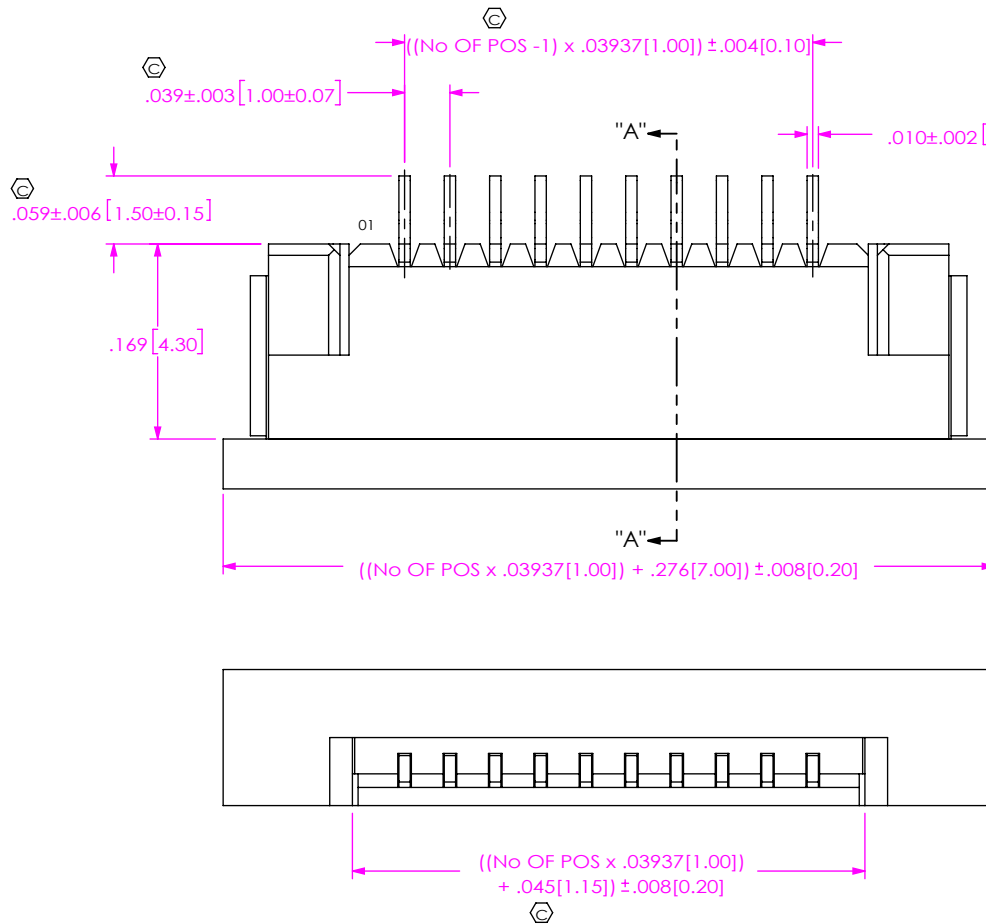

\*-03 LEAD STYLE AVAILABLE TO EXISTING CUSTOMERS ONLY AS OF REVISION P

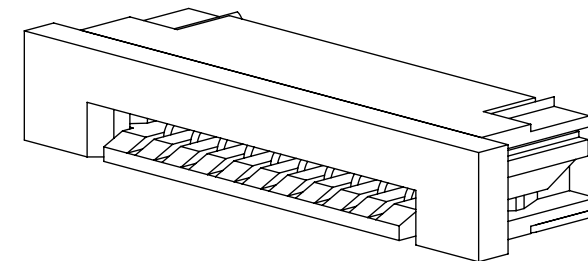
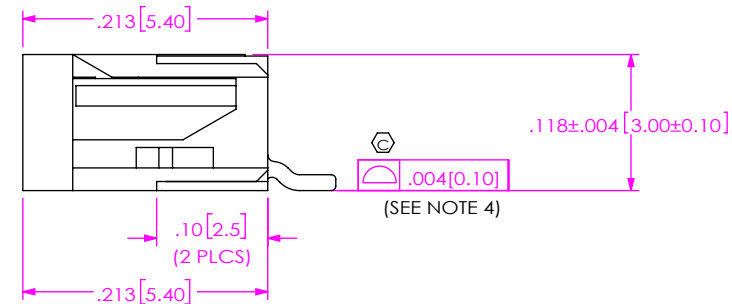

FIG 1  
ZF1-10-01-T-WT SHOWN  
(WITH CAM CLOSED)



NOTES:

- ⊕ REPRESENTS A CRITICAL DIMENSION.
- BURR ALLOWANCE: .0010[.025] MAXIMUM.
- CONTACT; MINIMUM PUSHOUT FORCE: 6 OZ.
- COPLANARITY INCLUDES TAILS AND WELD TABS.
- WELD TAB RETENTION: 12 OZ.
- BREAKOFF BURR NOT TO EXCEED .007[0.18] & MUST REMAIN ATTACHED.
- TUBES ARE STANDARD PACKAGING.
- ORDERS WILL BE PACKAGED ACCORDING TO THE SAMTEC PACKAGING EFFICIENCY STANDARDS (SPES) FOUND ON WWW.SAMTEC.COM.
- ATTACH LABEL TO EACH REEL.

UNLESS OTHERWISE SPECIFIED, DIMENSIONS ARE IN INCHES.  
TOLERANCES ARE:  
DECIMALS ANGLES  
.XX: ±.01[0.4] 2°  
.XXX: ±.010[0.25]  
.XXXX: ±.0005[0.125]

PROPRIETARY NOTE  
THIS DOCUMENT CONTAINS CONFIDENTIAL AND PROPRIETARY INFORMATION AND ALL DESIGN, MANUFACTURING, REPRODUCTION, USE, PATENT RIGHTS AND SALES RIGHTS ARE EXPRESSLY RESERVED BY SAMTEC, INC. THIS DOCUMENT SHALL NOT BE DISCLOSED, IN WHOLE OR PART, TO ANY UNAUTHORIZED PERSON OR ENTITY NOR REPRODUCED, TRANSFERRED OR INCORPORATED IN ANY OTHER PROJECT IN ANY MANNER WITHOUT THE EXPRESS WRITTEN CONSENT OF SAMTEC, INC.

MATERIAL: DO NOT SCALE DRAWING  
HOUSING: LCP E130i 94-V2, COLOR: NATURAL  
CAM SLIDER: PPS D5 94-V2, COLOR: BLACK  
CONTACT & WELD TAB: PHOS BRONZE  
MAX FLASH ALLOWED: .002  
MAX GATE VESTIGE: .002  
F:\DWG\MISC\MKTG\ZF1-XX-XX-XX-WT-XX-MKT.SLDDRW

SHEET SCALE: 6:1

DESCRIPTION:  
ZERO INSERTION FORCE 1mm ASSEMBLY  
DWG. NO.  
ZF1-XX-XX-XX-WT-XX  
BY: KEVIN B 9/20/2002 SHEET 1 OF 4



520 PARK EAST BLVD, NEW ALBANY, IN 47150  
PHONE: 812-944-6733 FAX: 812-948-5047  
e-Mail: info@SAMTEC.com code: 55322

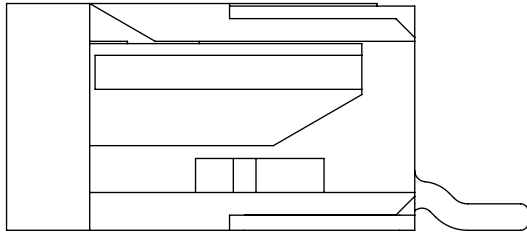

-01 LEAD STYLE [CONTACT BOTTOM]  
(WITH CAM OPEN)

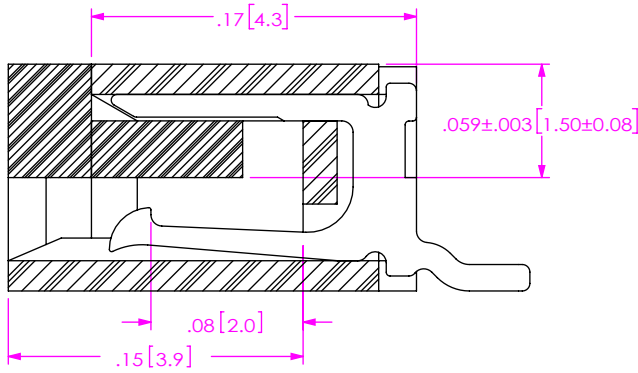

**SECTION "A"- "A"**  
-01 LEAD STYLE  
(WITH CAM CLOSED)

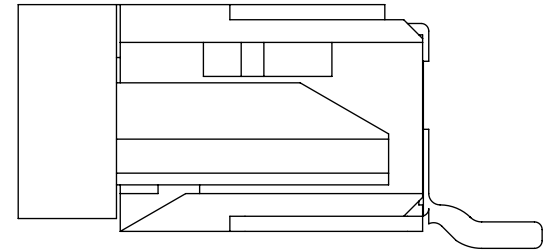

-02 LEAD STYLE [CONTACT TOP]  
(WITH CAM OPEN)

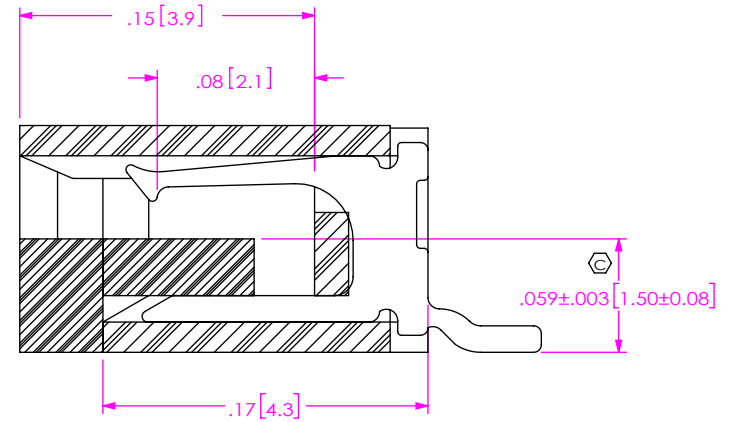

**SECTION "A"- "A"**  
-02 LEAD STYLE  
(WITH CAM CLOSED)

**PACKAGING VIEWS**  
(-TR OPTION SHOWN ON SHEET 4)

[PARTS TO HAVE POSITION # 1 LOADED IN  
SAME DIRECTION AS ARROW ON TUBE]

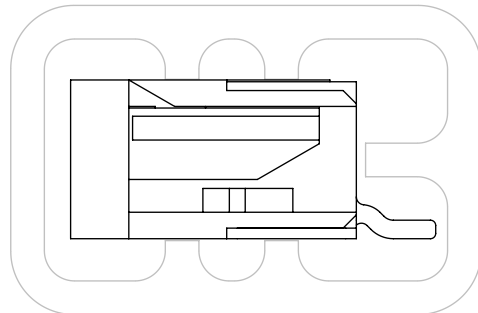

-01 & -02 LEAD STYLE:  
TUBE: PT-1-24-02-117  
PLUG: TP-24

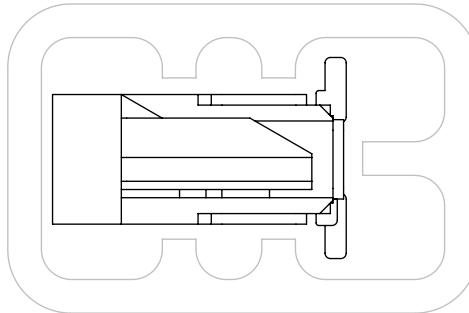

-03 LEAD STYLE:  
TUBE: PT-1-24-02-117  
PLUG: TP-24

F:\DWG\MISC\MKTG\ZF1-XX-XX-XX-WT-XX-MKT.SLDDRW

**PROPRIETARY NOTE**  
THIS DOCUMENT CONTAINS CONFIDENTIAL AND PROPRIETARY INFORMATION AND ALL DESIGN, MANUFACTURING, REPRODUCTION, USE, PATENT RIGHTS AND SALES RIGHTS ARE EXPRESSLY RESERVED BY SAMTEC, INC. THIS DOCUMENT SHALL NOT BE DISCLOSED, IN WHOLE OR PART, TO ANY UNAUTHORIZED PERSON OR ENTITY NOR REPRODUCED, TRANSFERRED OR INCORPORATED IN ANY OTHER PROJECT IN ANY MANNER WITHOUT THE EXPRESS WRITTEN CONSENT OF SAMTEC, INC.

DO NOT SCALE DRAWING

SHEET SCALE: 10:1

**samtec**

520 PARK EAST BLVD, NEW ALBANY, IN 47150  
PHONE: 812-944-6733 FAX: 812-948-5047  
e-Mail: info@SAMTEC.com code: 55322

DESCRIPTION:  
ZERO INSERTION FORCE 1mm ASSEMBLY

DWG. NO.  
**ZF1-XX-XX-XX-WT-XX**

BY: KEVIN B 9/20/2002 SHEET 2 OF 4

FIG 2  
 \* -03 LEAD STYLE  
 (SAME AS FIG 1, UNLESS OTHERWISE STATED)  
 (ZF1-10-03-T-WT SHOWN)

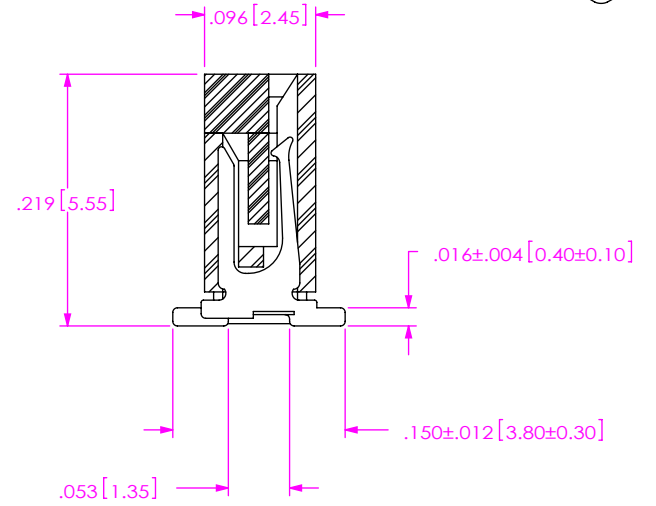
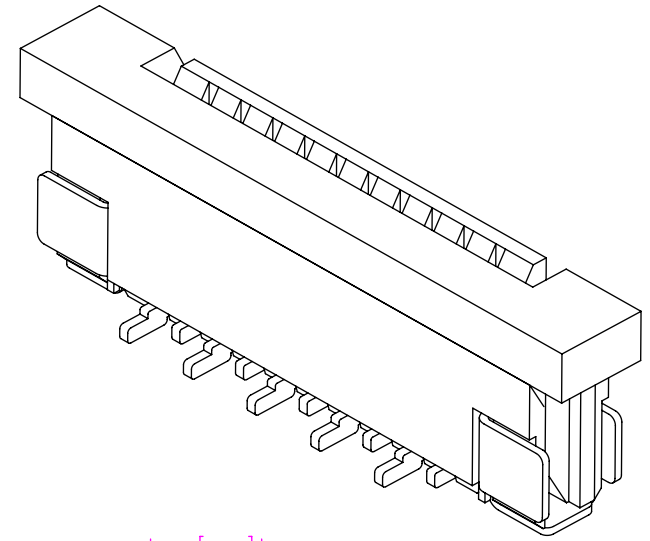
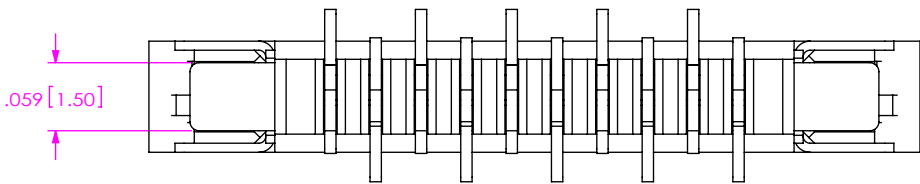
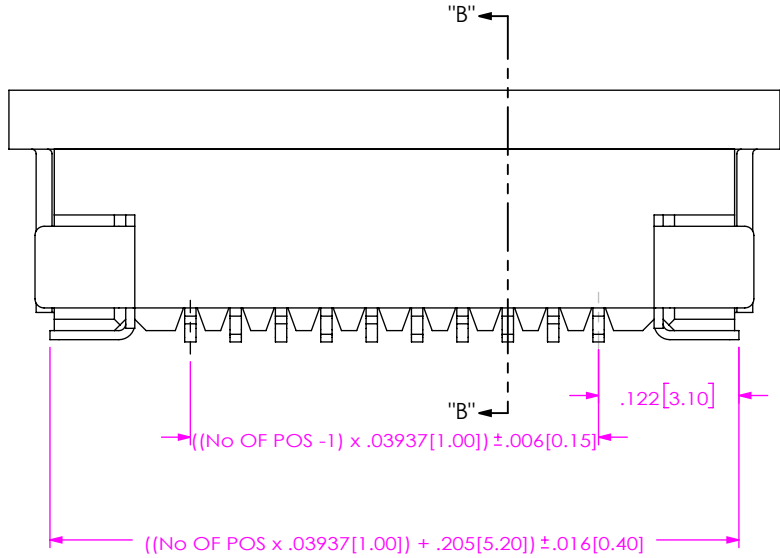
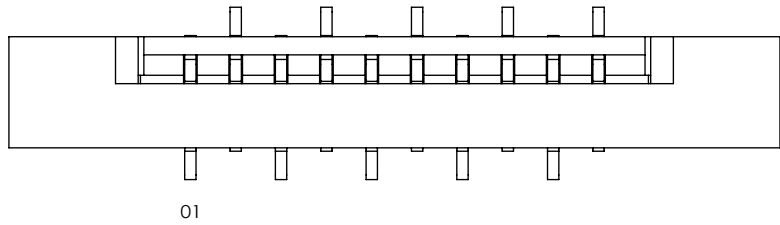

SECTION "B"- "B"

F:\DWG\MISC\MKTG\ZF1-XX-XX-XX-WT-XX-MKT.SLDDRW

**PROPRIETARY NOTE**  
 THIS DOCUMENT CONTAINS CONFIDENTIAL AND PROPRIETARY INFORMATION AND ALL DESIGN, MANUFACTURING, REPRODUCTION, USE, PATENT RIGHTS AND SALES RIGHTS ARE EXPRESSLY RESERVED BY SAMTEC, INC. THIS DOCUMENT SHALL NOT BE DISCLOSED, IN WHOLE OR PART, TO ANY UNAUTHORIZED PERSON OR ENTITY NOR REPRODUCED, TRANSFERRED OR INCORPORATED IN ANY OTHER PROJECT IN ANY MANNER WITHOUT THE EXPRESS WRITTEN CONSENT OF SAMTEC, INC.

DO NOT SCALE DRAWING

SHEET SCALE: 6:1



520 PARK EAST BLVD, NEW ALBANY, IN 47150  
 PHONE: 812-944-6733 FAX: 812-948-5047  
 e-Mail: info@SAMTEC.com code: 55322

DESCRIPTION:  
 ZERO INSERTION FORCE 1mm ASSEMBLY

DWG. NO.  
**ZF1-XX-XX-XX-WT-XX**

BY: KEVIN B 9/20/2002 SHEET 3 OF 4

FIG 3  
-XR OPTION

-01 LEAD STYLE

NOTE: POS 1 CLOSEST TO ROUND HOLES

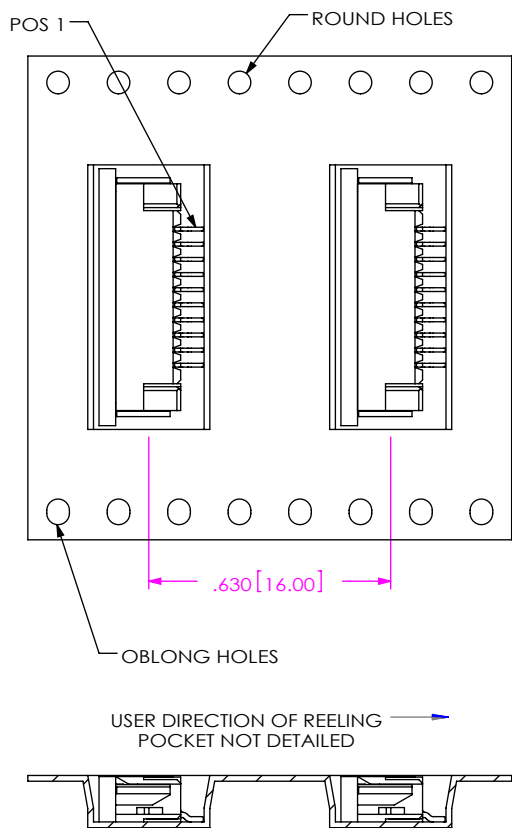

-02 LEAD STYLE

NOTE: POS 1 CLOSEST TO OBLONG HOLES

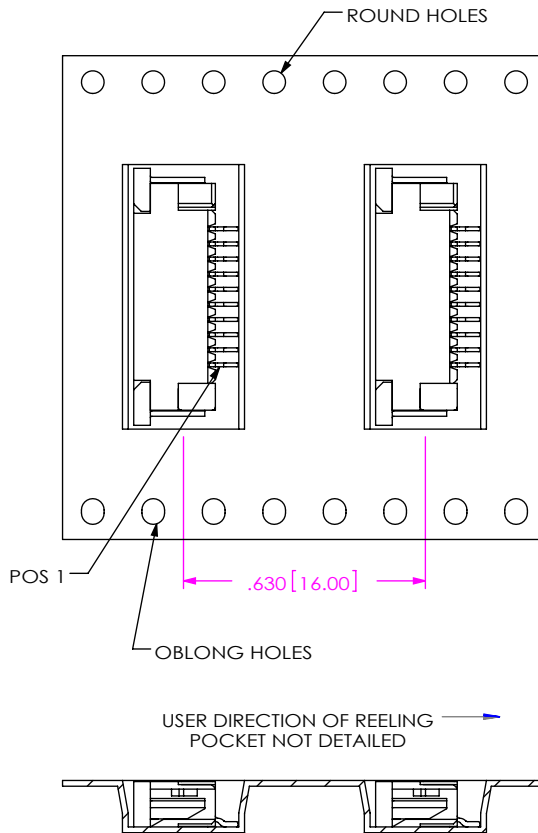

-03 LEAD STYLE

NOTE: POS 1 CLOSEST TO ROUND HOLES

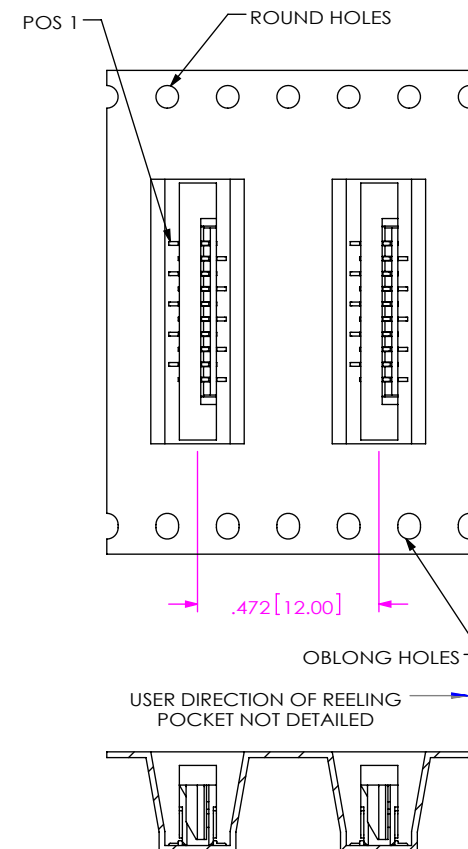

F:\DWG\MISC\MKTG\ZF1-XX-XX-XX-WT-XX-MKT.SLDDRW

**PROPRIETARY NOTE**  
 THIS DOCUMENT CONTAINS CONFIDENTIAL AND PROPRIETARY INFORMATION AND ALL DESIGN, MANUFACTURING, REPRODUCTION, USE, PATENT RIGHTS AND SALES RIGHTS ARE EXPRESSLY RESERVED BY SAMTEC, INC. THIS DOCUMENT SHALL NOT BE DISCLOSED, IN WHOLE OR PART, TO ANY UNAUTHORIZED PERSON OR ENTITY NOR REPRODUCED, TRANSFERRED OR INCORPORATED IN ANY OTHER PROJECT IN ANY MANNER WITHOUT THE EXPRESS WRITTEN CONSENT OF SAMTEC, INC.

SHEET SCALE: 2:1



520 PARK EAST BLVD, NEW ALBANY, IN 47150  
 PHONE: 812-944-6733 FAX: 812-948-5047  
 e-Mail: info@SAMTEC.com code: 55322

DESCRIPTION:  
 ZERO INSERTION FORCE 1mm ASSEMBLY

DWG. NO.  
 ZF1-XX-XX-XX-WT-XX

BY: KEVIN B 9/20/2002 SHEET 4 OF 4