

REVISIONS					
P	LTR	DESCRIPTION	DATE	DWN	APVD
-	A	RELEASED FOR PRODUCTION	07MAR2016	TX	SH
	AI	REVISED PER ECN-22-144211	25MAR2022	JG	DZ

NOTES:

- 1 MATERIAL:  
HOUSING: HIGH TEMP THERMOPLASTIC, UL94V-0,  
COLOR: BLACK  
CONTACT: COPPER ALLOY  
HOLD DOWN: COPPER ALLOY
- 2 FINISH:  
CONTACT AREA: MIN 0.76um GOLD PLATING  
SOLDERTAIL: MIN 2.54um MATTE TIN PLATING  
UNDERPLATE: MIN 1.27um NICKEL PLATING
- 3 PIN #P4 AND #P12 ONLY
- 4 SOLDERTAIL TO BE 0.05 MAX ABOVE AND 0.10 MAX BELOW DATUM E
- 5 1.33 MAX MEASURED AT DATUM C

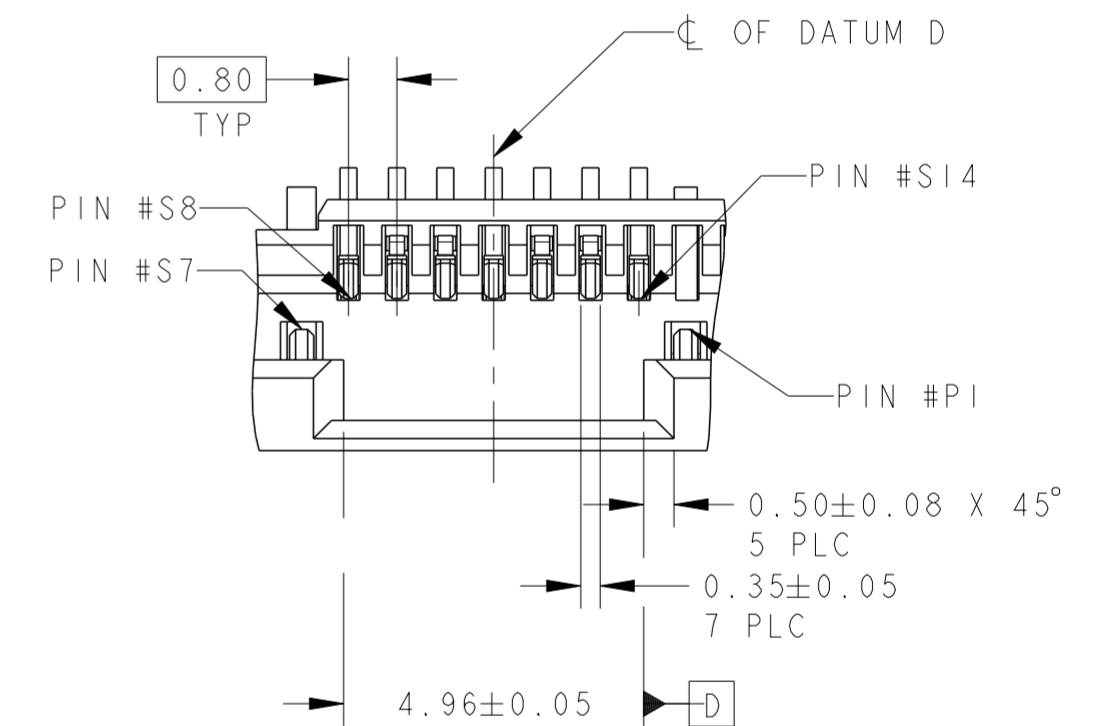
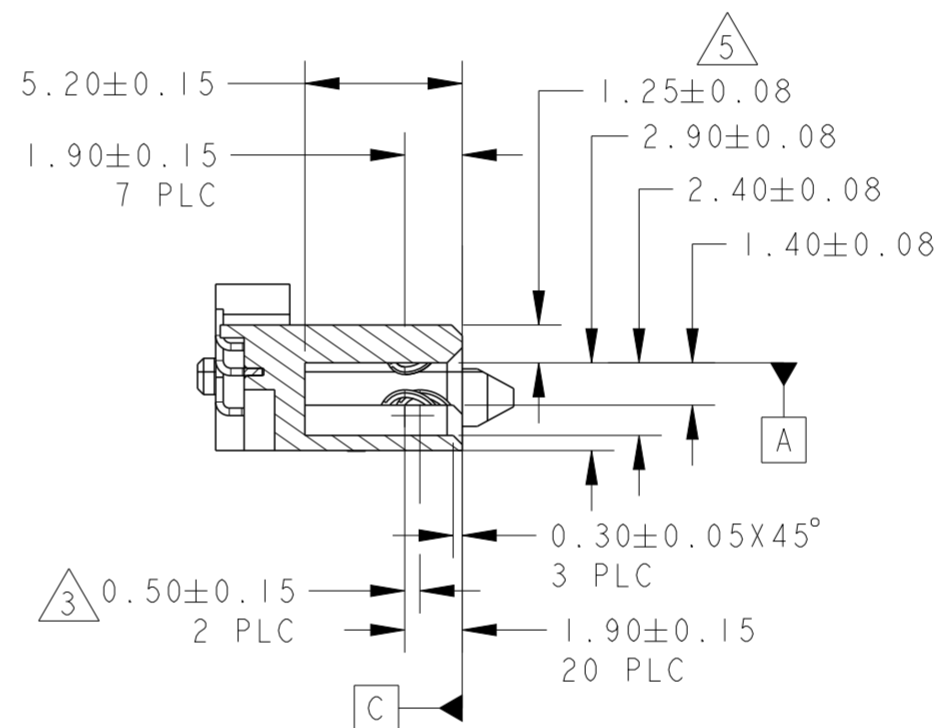
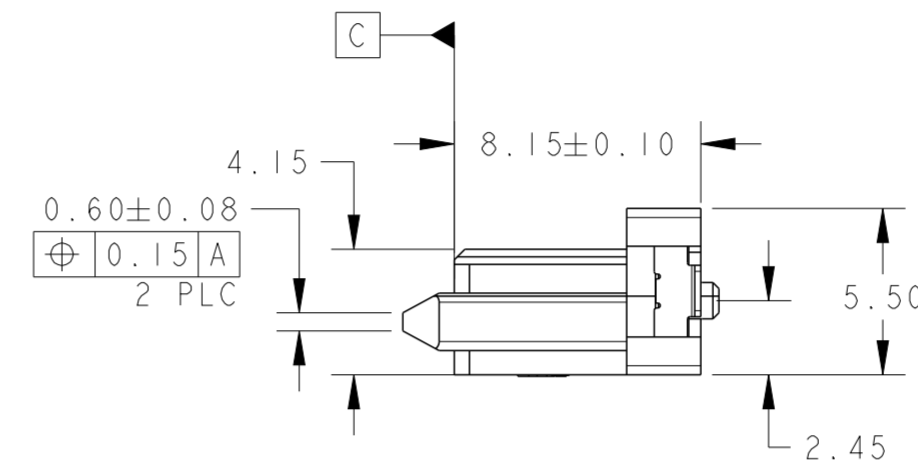
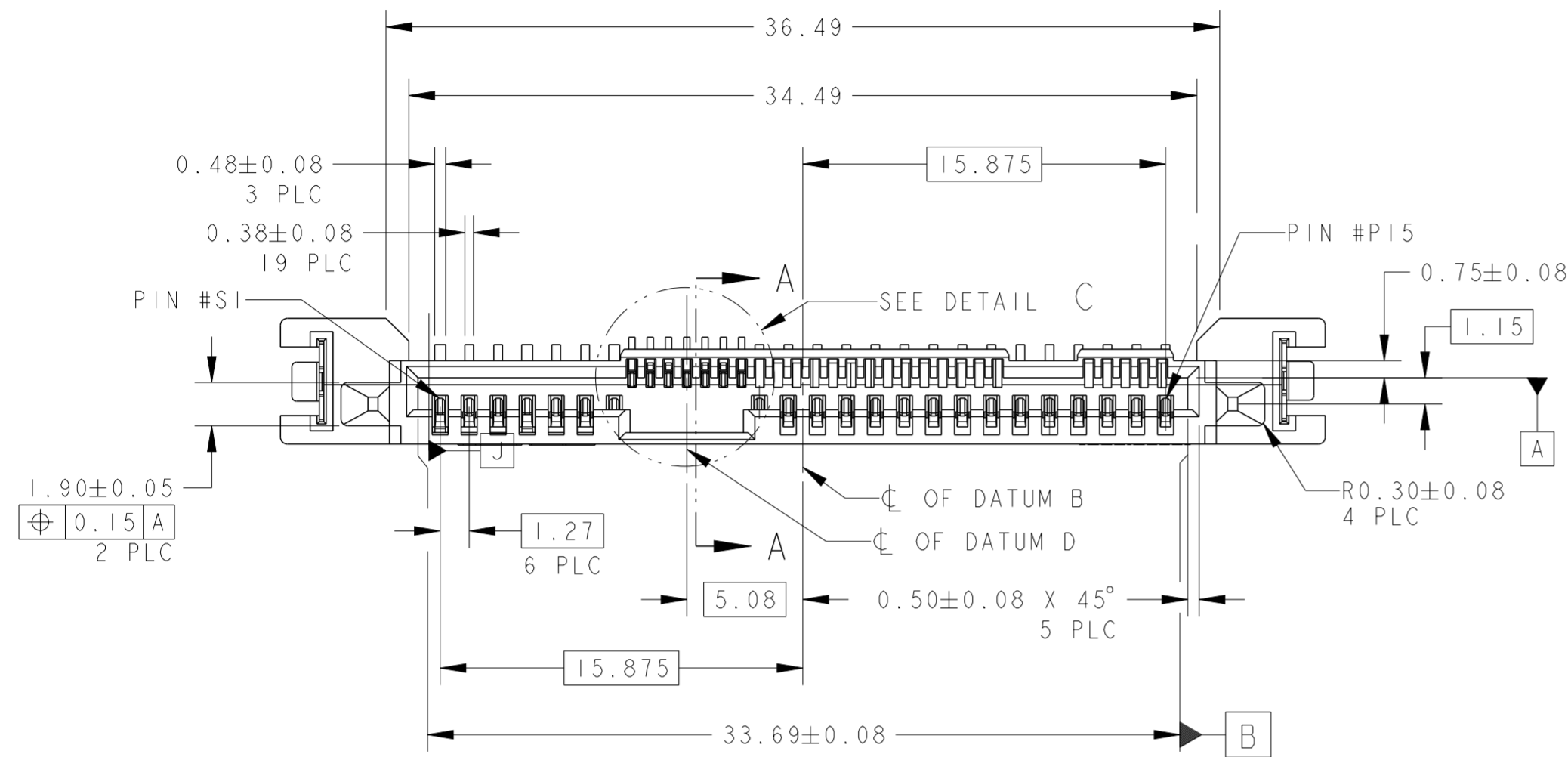

DETAIL C  
SCALE 8:1

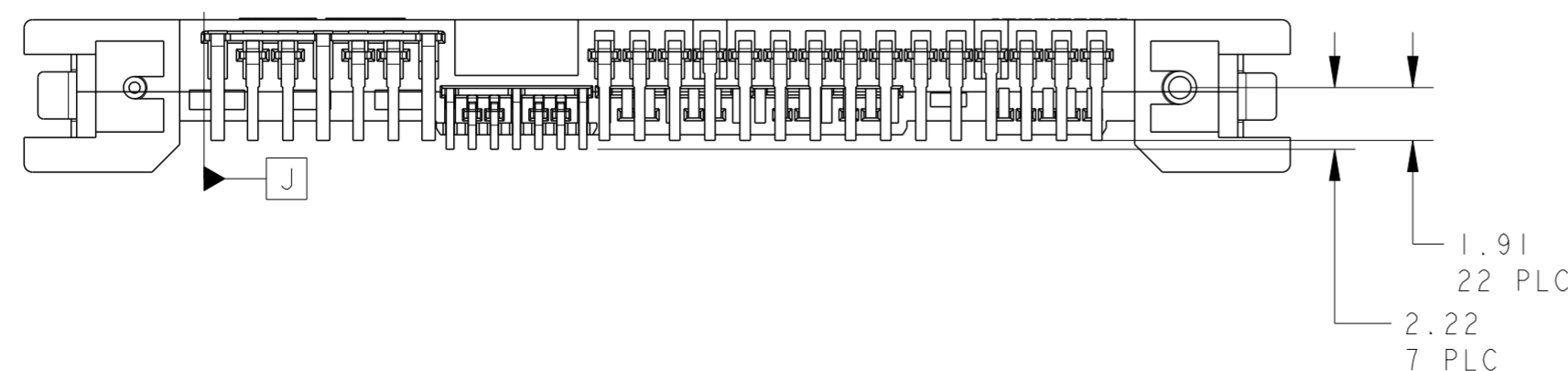
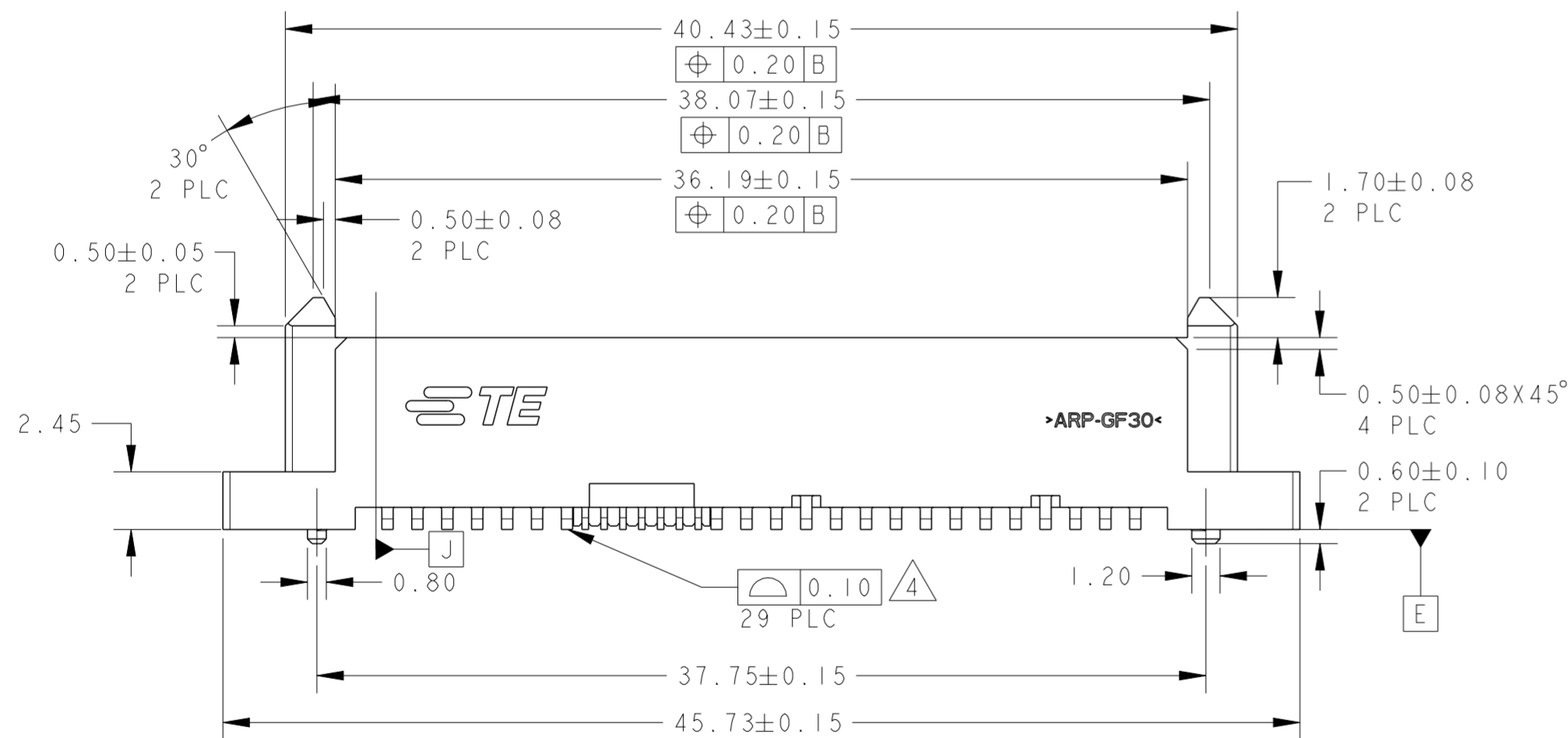

P/N: 1735880-1 AS SHOWN

**OBSELETE**

TAPE AND REEL	YES	1735880-2
TAPE AND REEL	NO	1735880-1
PACKAGE	PICK-UP CAP (1)	PART NUMBER

THIS DRAWING IS A CONTROLLED DOCUMENT.		DWN TY PANG 16FEB2011	TE Connectivity	
DIMENSIONS: mm		CHK SF LEONG 27JUN2011		
TOLERANCES UNLESS OTHERWISE SPECIFIED:		APVD SF LEONG 27JUN2011	NAME 12G SAS BACKPLANE RECEPTACLE, VERTICAL, SMT, SMT SOLDER PEG DUAL PORT	
0 PLC ± 1 PLC ±0.20 2 PLC ±0.15 3 PLC ± 4 PLC ±		PRODUCT SPEC 108-51109	SIZE 114-60017	
ANGLES ±3° FINISH		APPLICATION SPEC	RESTRICTED TO	
MATERIAL (1)		WEIGHT	SCALE A200779 C-1735880	
		CUSTOMER DRAWING	SCALE 4:1	SHEET 1 OF 2 REV AI

REVISIONS					
P	LTR	DESCRIPTION	DATE	DWN	APVD
-		SEE SHEET 1	-	-	-

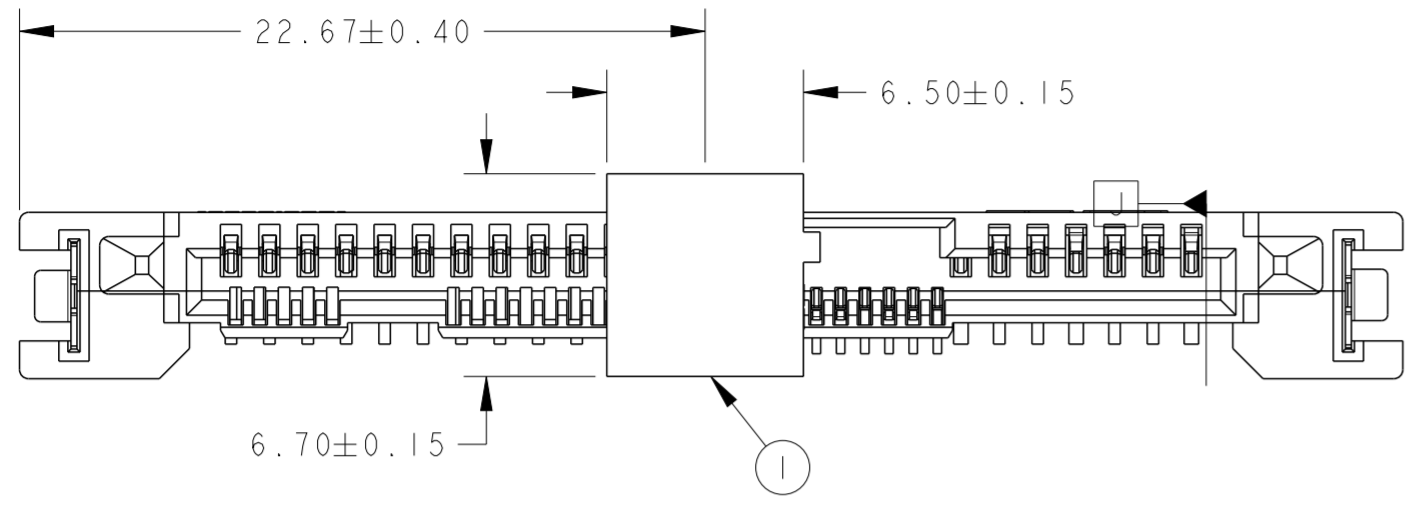

P/N: 1735880-2 AS SHOWN

**OBSOLETE**

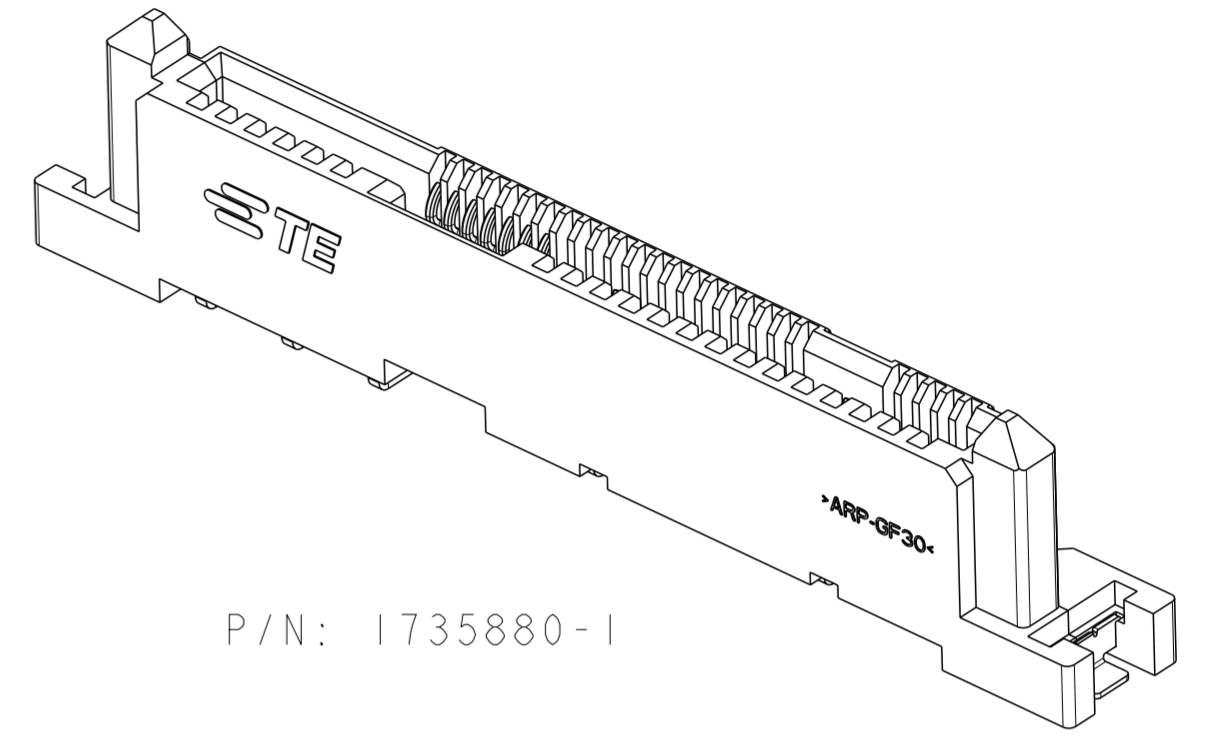

P/N: 1735880-1

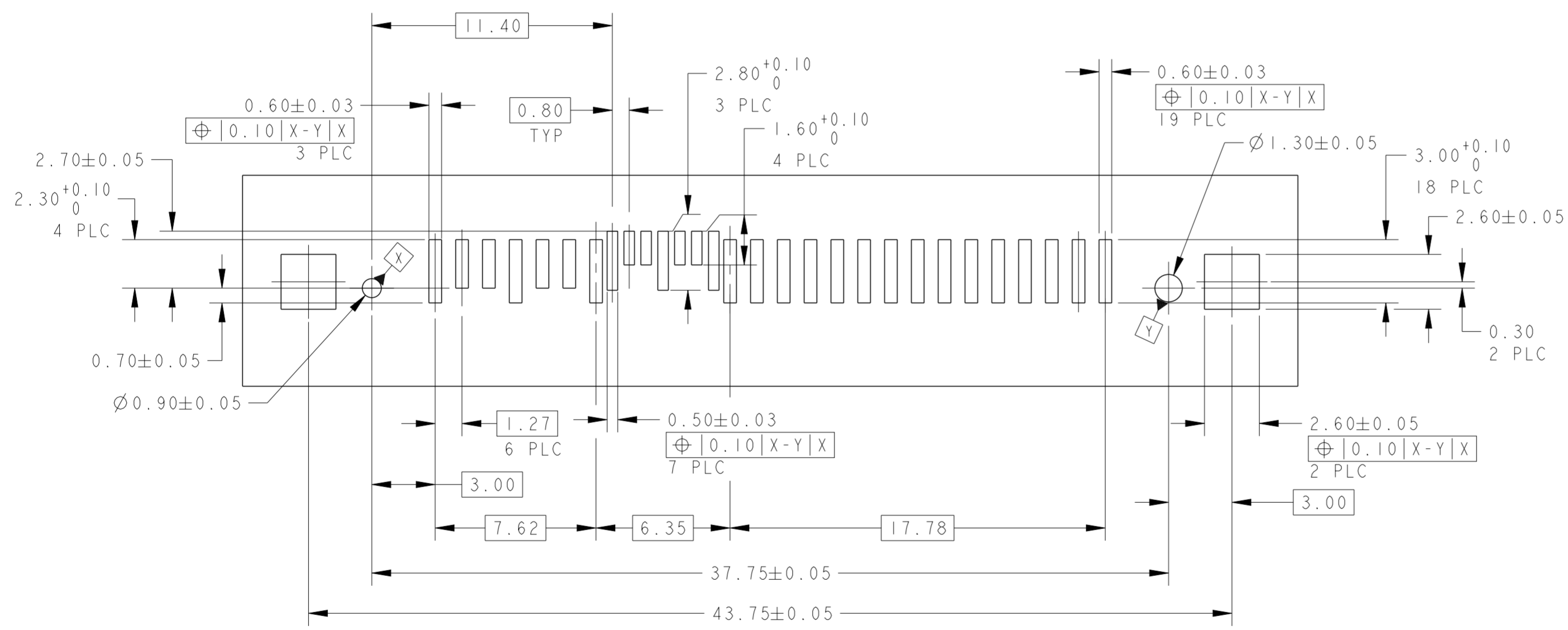

RECOMMENDED PCB LAYOUT  
SCALE 5:1

THIS DRAWING IS A CONTROLLED DOCUMENT.		DWN TY PANG 16FEB2011	TE Connectivity	
DIMENSIONS: mm		CHK SF LEONG 27JUN2011		
TOLERANCES UNLESS OTHERWISE SPECIFIED:		APVD SF LEONG 27JUN2011	NAME 12G SAS BACKPLANE RECEPTACLE, VERTICAL, SMT, SMT SOLDER PEG DUAL PORT	
0 PLC ±-		PRODUCT SPEC 108-51109	SIZE A200779	
1 PLC ±0.20		APPLICATION SPEC 114-60017	DRAWING NO C-1735880	
2 PLC ±0.15		WEIGHT -	RESTRICTED TO -	
3 PLC ±-		CUSTOMER DRAWING	SCALE 4:1	
4 PLC ±-			SHEET 2 OF 2	
ANGLES ±3°			REV A1	
FINISH -				