

Applications

- Low phase noise oscillators up to 16 GHz
- VCO's, DRO's and YIG oscillators
- Point-to-point radios
- Satellite communications
- Fiber optics, OC-192 and OC-768
- Local Multipoint Distribution Systems, LMDS

Features

- Low 1/f noise: -142 dBc/Hz at 100 Hz offset
- Phase noise: -167 dBc/Hz at 100 kHz offset
- Output power up to +13 dBm
- Operation down to 1 volt, 2 mA
- Gold bump pads for wire bond or flip chip (for direct die attachment)

Product Description

The LPT16ED is a silicon germanium low phase noise, high frequency NPN transistor for oscillator applications up to 16GHz.

The transistor exhibits low 1/f noise and provides +13 dBm typical output power at V_{CE} of 3V and I_C equal to 20 mA. It is easily operated from a single supply voltage with appropriate external passive components.

The silicon germanium technology used in this device provides outstanding high-frequency performance combined with high thermal conductivity and superior reliability under harsh operating and storage conditions.

A complete mechanical description of the transistor is available under SiGe Semiconductor Document 07MS001.

Ordering Information

Type	Package	Remark
LPT16ED	Bare Die	Shipped in Waffle Pack

Functional Block Diagram

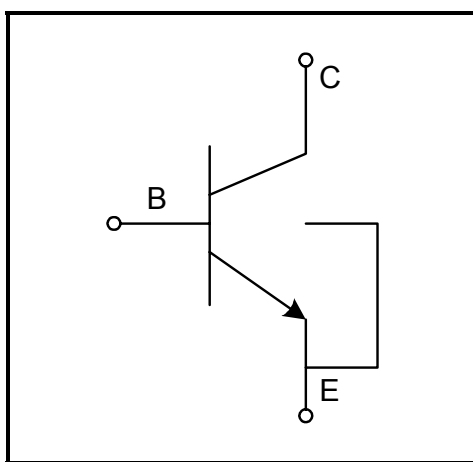

Absolute Maximum Ratings

Operation in excess of any one of Absolute Maximum Ratings may result in permanent damage. This is a high performance RF device with ESD rating < 2keV. Handling and assembly of this device should be done at ESD protected workstations.

Symbol	Parameter	Min.	Max.	Unit
V _{CBO}	Collector to Base Voltage		+13.0	V
V _{CEO}	Collector to Emitter Voltage		+4.0	V
V _{EBO}	Emitter to Base Voltage		+1.5	V
I _C	Collector Current		80	mA
I _B	Base Current		2.0	mA
P _T	Total Power Dissipation		250	mW
T _J	Junction Temperature		+150	°C
T _{STG}	Storage Temperature	-65	+150	°C

DC Electrical Characteristics

Conditions: T_A = unless otherwise specified 25°C

Symbol	Parameter	Condition	Min.	Typ.	Max.	Unit
V _{BE}	Base-emitter voltage	I _C = 1μA	670	687	700	mV
BV _{CEO}	Collector-emitter breakdown voltage	Open base	4.0	4.5	5.0	V
BV _{CES}	Collector-emitter breakdown voltage	Base-emitter shorted via 100kΩ	14	15.0	16	V
BV _{EBO}	Emitter-base breakdown voltage	I _E = 100μA, open collector	2.0	2.3	2.6	V
BV _{CBO}	Collector-base breakdown voltage	Open emitter	14	15.0	16	V
V _A	Early voltage	I _C = 10mA, V _{CE} = 3V	100	200	300	V
I _{CBO}	Collector-base cutoff current	V _{CB} = 5V and I _E = 0			100	pA
I _{EBO}	Emitter-base cutoff current	V _{EB} = 1.5V and I _C = 0	5	10	15	μA
h _{FE}	DC current gain	V _{CE} = 2V, I _C = 20mA	50	60	150	

AC Electrical Characteristics

Symbol	Parameter	Note	Min.	Typ.	Max.	Unit
IS ₂₁ l ₂	Insertion Power Gain (Z _S = Z _L = 50Ω)	V _{CE} = 1.5V, I _C = 10mA, f = 16GHz	0.7	1.0	1.3	dB
		V _{CE} = 3.0V, I _C = 20mA, f = 16GHz	2.3	2.6	2.9	dB
MAG/ MSG	Maximum Available Gain or Maximum Stable Gain	V _{CE} = 1.5V, I _C = 10mA, f = 16GHz	3.3	3.6	4.2	dB
		V _{CE} = 3.0V, I _C = 20mA, f = 16GHz	4.9	5.2	5.6	dB

Typical Performance Characteristics

Please refer to application note (Document 07AN001).

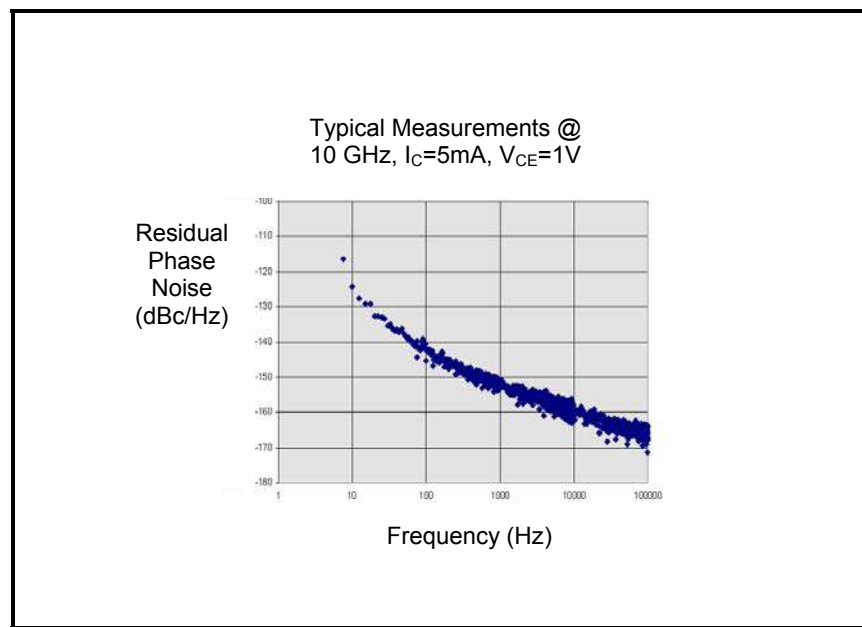

Typical Applications Information

Series or parallel feedback oscillators at 5-16 GHz. (Please refer to application note, Document 07AN001).

Die and Pad Description

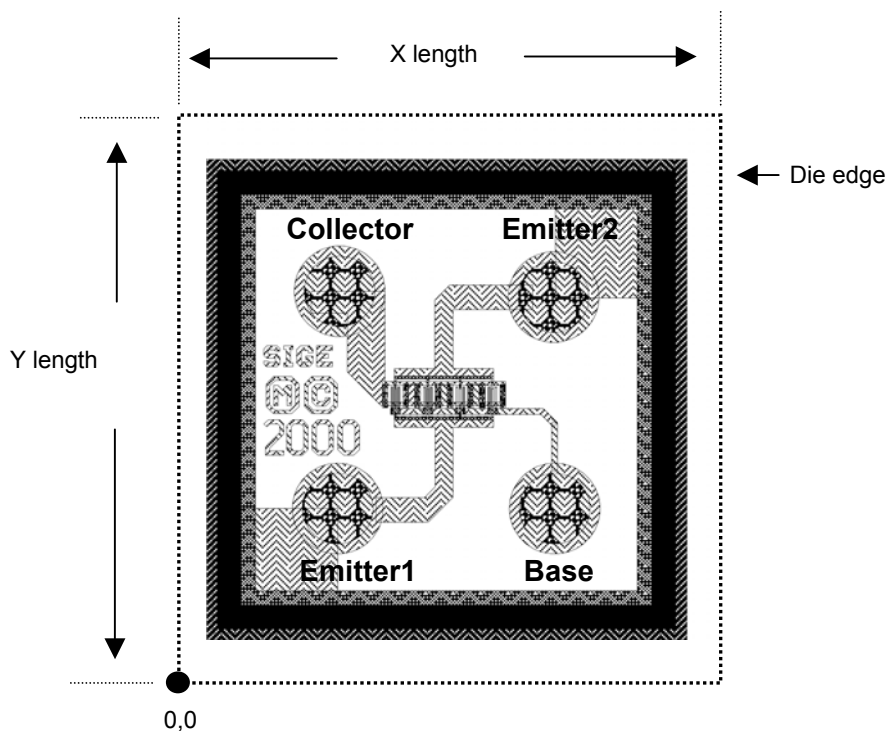

Dimensions are relative to the 0,0 cut die corner.

Feature	Specification	Comments
Die thickness	10 mil +/- 1mil	
X length	15.3 mil +/- 1mil	
Y length	14.5 mil +/- 1mil	
Pad diameter	2.9 mil +/- 0.1mil	Pads are circular.
Pad pitch	6 mil +/- 0.1mil	Pad center to pad centre
Pad/bump height	1 mil +/- 0.05mil	
Pad/bump co-planarity	0.2 mil	

Pad Center	Position (X mil, Y mil) +/- 0.7mil relative to the 0,0 cut die corner
Collector	5, 11
Emitter1	5, 5
Base	11, 5
Emitter 2	11, 11

Please refer to Document 01-MS-001 for SiGe's die inspection criteria.

For S-parameter data, please refer to SiGe Document 07SP001.

<http://www.sige.com>

Headquarters: Canada

Phone: +1 613 820 9244

Fax: +1 613 820 4933

2680 Queensview Drive

Ottawa ON K2B 8J9 Canada

sales@sige.com

San Diego

Phone: +1 858 668 3541

Fax: +1 858 668 3546

Hong Kong

Phone: +1 852 9177 1917

United Kingdom

South Building, Walden Court
Parsonage Lane, Bishop's Stortford
Hertfordshire CM23 5DB

Phone: +44 1279 464 200

Fax: +44 1279 464 201

Product Preview

The datasheet contains information from the product concept specification. SiGe Semiconductor Inc. reserves the right to change information at any time without notification.

Preliminary Information

The datasheet contains information from the design target specification. SiGe Semiconductor Inc. reserves the right to change information at any time without notification.

Final

The datasheet contains information from the final product specification. SiGe Semiconductor Inc. reserves the right to change information at any time without notification. Production testing may not include testing of all parameters.

Information furnished is believed to be accurate and reliable and is provided on an "as is" basis. SiGe Semiconductor Inc. assumes no responsibility or liability for the direct or indirect consequences of use of such information nor for any infringement of patents or other rights of third parties, which may result from its use. No license or indemnity is granted by implication or otherwise under any patent or other intellectual property rights of SiGe Semiconductor Inc. or third parties. Specifications mentioned in this publication are subject to change without notice. This publication supersedes and replaces all information previously supplied. SiGe Semiconductor Inc. products are NOT authorized for use in implantation or life support applications or systems without express written approval from SiGe Semiconductor Inc.

RangerCharger™, StreamCharger™, PointCharger™, and LightCharger™ are trademarks owned by SiGe Semiconductor Inc.

Copyright 2002 SiGe Semiconductor
All Rights Reserved

This datasheet has been download from:

www.datasheetcatalog.com

Datasheets for electronics components.