

E-I Matched Bead Thermistor 115 Series

009096

Issue 1

Datasheet



DESCRIPTION

Honeywell's 115 Series E-I Matched Bead Thermistors are built using the 111 Series Small Bead Thermistors that are hermetically sealed in glass. They feature relatively uniform size, offer fast time response, and are highly sensitive to temperature changes and airflow movements. They are often suited for use in low heat capacity applications, and their small size allows them to be used in confined locations.

In the 115 Series, Honeywell has taken the Small Beads' performance and reliability and mounted them to a special hermetically sealed header to facilitate ease of installation.

For maximum sensitivity, the higher resistance units should be used at higher ambient temperatures.

VALUE TO CUSTOMERS

- Less expensive to implement than most other gas analyzing technologies
- 2000 and 8000 Ohm decades available
- Thermistor pairs are precision matched to one another which eliminates the need for performing individual thermistor calibrations

DIFFERENTIATION

- This technology is non-destructive to mediums being measured
- Can be utilized in gas streams that are in constant use
- Versatile for detecting a variety of gases that have different thermal conductivities than the carrier gas (most other technologies are dedicated to one particular gas or medium)

FEATURES

- E-I matched in air or helium
- Resistance matched at 25 °C [77 °F]
- Interchangeable parts
- Long life
- Compression type glass seal
- High pressure solder seal

POTENTIAL APPLICATIONS

- Gas analysis instruments
- Gas/Airflow detection
- Thermal conductivity analysis
- Temperature sensing and monitoring equipment
- Vacuum sensing equipment
- Medical electronics
- Industrial controls
- Test equipment

PORTFOLIO

Honeywell offers 18 series of thermistors, as well as a broad spectrum of thermal products. The entire breadth of Honeywell's thermistor series can be viewed [here](#).

E-I Matched Bead Thermistor, 115 Series

Table 1. Specifications

Characteristic	115-202CDK-801	115-802EDJ-801*, 115-802EDJ-802
Description	Two 111-202CAK-H01 each mounted on a glass hermetic sealed header and matched in air to within 10 mV of each other	Two 111-802EAJ-H01 each mounted on a glass hermetic sealed header and matched in helium* or air to within millivolts of each other at 2 mA, 5 mA, 10 mA, and 15 mA Matched to 2 % resis. at 25 °C [77 °F]
Resistance at 25 °C [77 °F]	2000 Ohms ±25 %	8000 Ohms ±20 %
Resistance at 0 °C [32 °F] approx.	5000 Ohms	22800 Ohms
Resistance at 50 °C [122 °F] approx.	910 Ohms	3240 Ohms
Ratio of resistance 0 °C/50 °C	4.95 to 6.95	6.34 to 7.74
BETA 0 °C/50 °C (nominal)	3000K	3442K
Temperature coefficient @ 25 °C [77 °F]	-3.4%/°C	-3.9%/°C
T/C still air max.**	0.5 second	0.5 second
D.C. still air**	0.16 mW/°C	0.16 mW/°C
D.C. helium**	0.5 mW/°C	0.5 mW/°C
Power ratio (air)	15 mW	45 mW
Power ratio (helium)	60 mW	140 mW
Max. ambient temp	100 °C [212 °F]	250 °C [482 °F]
Max. operating temp. (including self-heat)	150 °C [302 °F]	300 °C [572 °F]
Resistance at max. operating temp.	85 Ohm	25 Ohm
Pair matched Ro at 25 °C [77 °F]	5 % ¹	2 % ¹
EI pair matching	still air at 25 °C [77 °F] to 10 mV at 5 mA ¹ 10 mV at 10 mA ¹ 10 mV at 15 mA ¹	* helium at 25 °C [77 °F] to 20 mV at 2 mA ¹ 15 mV at 5 mA ¹ 10 mV at 15 mA ¹ still air at 25 °C [77 °F] to 20 mV at 2 mA ¹ 15 mV at 5 mA ¹ 10 mV at 10 mA ¹

¹ Standard matched tolerance. Other tolerances available, please contact Honeywell for details.

² Non-matched options on header also available, please contact Honeywell for details.

**D.C. – Power in milliwatts required to raise thermistor temperature 1 °C

**T/C – Time required for thermistor to indicate 63 % of a new impressed temperature.

E-I, 115 SERIES DIMENSIONS

mm [in] for reference only

Figure 1. E-I 115 Series Dimensions

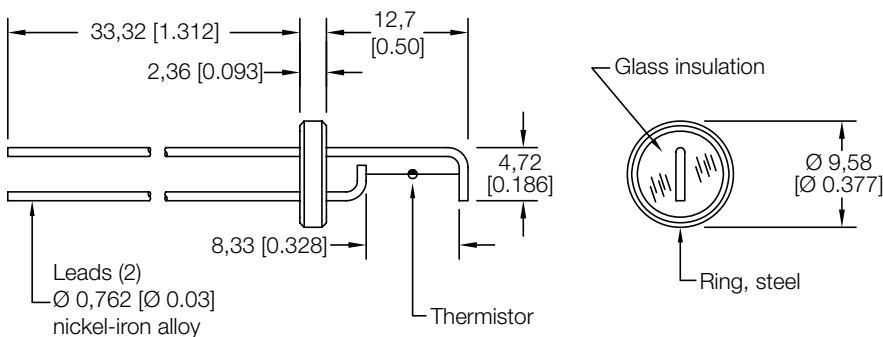

E-I Matched Bead Thermistor, 115 Series

Using thermistors in thermal conductivity instruments

Many physical phenomena such as liquid or gas flow, vacuum measurements, liquid level, changes in gas composition, etc., which involve changes in the thermal conductivity of a medium, can be accurately measured and monitored by means of thermistors.

Thermistors are uniquely qualified as transducers in such applications because of two inherent characteristics. The first is their high sensitivity to small variations in their own temperature. The second is their ability to operate in a "self-heated" mode. When a current of significant magnitude is passed through a thermistor, the temperature of the latter increases until the power in the circuit is balanced by the heat dissipated from the thermistor.

Gas Chromatography

When used in thermally conductivity measurements, two thermistors are normally connected to adjacent legs of the Wheatstone bridge with the voltage applied at their junction. Enough voltage is applied to heat both units considerably above ambient (typically to about 150 °C [302 °F]).

Figure 2. Percent CO vs. Millivolt Deflection

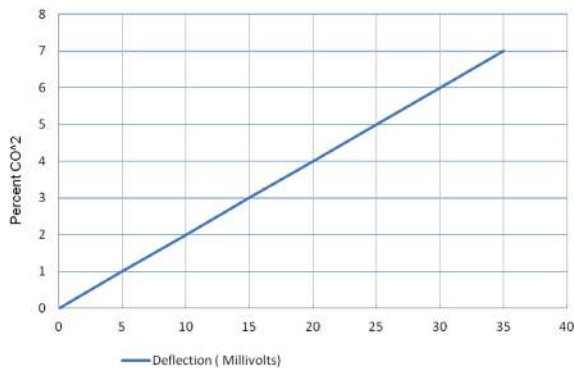

Each of the other bridge legs must be greater in resistance than the negative resistance of the thermistor at their operating point. This is determined by the slope of the thermistor EI curve. ($\Delta E/\Delta I$). Moreover, the impedance of the readout device must be greater than the sum of thermistors negative resistance.

Figure 3. Typical Thermistors Thermal Conductivity Measurement Circuit

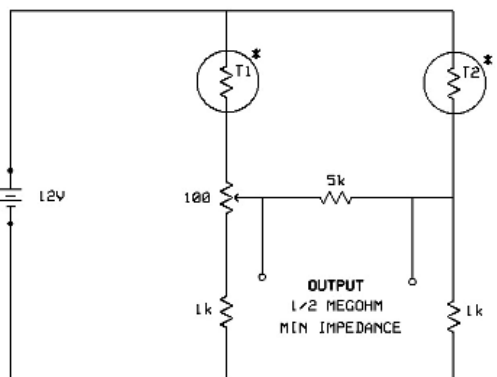

* 115-802EDJ-801 MATCHED PAIR

One thermistor is mounted in a static area to provide for temperature compensation while the other is placed in the medium to be measured. Any change in the thermal conductivity of this medium will change the rate at which heat is dissipated from sensing thermistor, thus changing its temperature. This results in bridge unbalance, which can be calibrated in appropriate units.

In a typical application, two thermistors, connected in a bridge circuit, are placed in separate cavities in a brass block. With air in both cavities the bridge is balanced. When the air in one cavity is replaced by carbon dioxide, the bridge will be unstable because the carbon dioxide has a low thermal conductivity than air and that thermistor becomes hotter and lower in resistance. The amount of unbalance represents 100 % CO₂ in the analyzer. 50 % CO₂ gives just have to meter reading and the instrument may therefore be calibrated with a linear scale to read in % CO₂ in the air. Similar calibration may be made for any of the mixture of two gases. A specific circuit for such an instrument is shown in Figure 3. Its output is shown in Figure 2.

Airflow

With slight changes in physical design such a device may be used as a flow-meter, which can measure flow rates as low as 0.001 c.c./minute and can cover a range of 100,000 to 1 or more. If the same bridge is made with one thermistors sealed in a cavity in a brass block and the other mounted in a small pipe, it may be used as a flow meter. When no air is flowing through the pipe, the bridge may be balanced. When air flows through the pipe, the thermistor is cooled and its resistance increases which unbalances the bridge. The amount of cooling is proportional to the rate of flow of the air and the meter may be calibrated in terms of flow rate in the pipe. The same instrument may be used for measuring flow rate of any gas or liquid. Such instruments have been made to measure flow rates as low as 0.001 c.c./minute. One instrument can measure flow rates over ranges of 100,000 to 1 or more.

If the same instrument is made with the sensing thermistor half in free air, it becomes an anemometer capable of measuring air velocity from the slightest breeze to gale and can be calibrated in terms of miles per hour of wind velocity.

Vacuum

Similarly, thermistors are used as broad range vacuum gages which are useful from about 10 mm to 10⁻⁵ mm of Hg. If one of the thermistors is mounted in a sealed, evacuated bulb, and the other is mounted in a chamber connected to a vacuum pump, it may be calibrated as a vacuum gage in terms of mm of mercury. By pumping the chamber down to a high vacuum and balancing the bridge, output will be obtained when the chamber is not at high vacuum because the presence of air will cool the thermistor etc.

ADDITIONAL MATERIALS

The following associated literature is available on the Honeywell web site at sensing.honeywell.com:

- Product line guide
- Product range guide

WARNING **PERSONAL INJURY**

DO NOT USE these products as safety or emergency stop devices or in any other application where failure of the product could result in personal injury.

Failure to comply with these instructions could result in death or serious injury.

WARNING **MISUSE OF DOCUMENTATION**

- The information presented in this product sheet is for reference only. Do not use this document as a product installation guide.
- Complete installation, operation, and maintenance information is provided in the instructions supplied with each product.

Failure to comply with these instructions could result in death or serious injury.

Find out more

Honeywell serves its customers through a worldwide network of sales offices, representatives and distributors. For application assistance, current specifications, pricing or name of the nearest Authorized Distributor, contact your local sales office. To learn more about Honeywell's sensing and switch products, call **+1-815-235-6847** or **1-800-537-6945**, visit **sensing.honeywell.com**, or e-mail inquiries to **info.sc@honeywell.com**

Sensing and Productivity Solutions
Honeywell
1985 Douglas Drive North
Golden Valley, MN 55422
honeywell.com

Warranty/Remedy

Honeywell warrants goods of its manufacture as being free of defective materials and faulty workmanship. Honeywell's standard product warranty applies unless agreed to otherwise by Honeywell in writing; please refer to your order acknowledgement or consult your local sales office for specific warranty details. If warranted goods are returned to Honeywell during the period of coverage, Honeywell will repair or replace, at its option, without charge those items it finds defective. **The foregoing is buyer's sole remedy and is in lieu of all other warranties, expressed or implied, including those of merchantability and fitness for a particular purpose. In no event shall Honeywell be liable for consequential, special, or indirect damages.**

While we provide application assistance personally, through our literature and the Honeywell web site, it is up to the customer to determine the suitability of the product in the application.

Specifications may change without notice. The information we supply is believed to be accurate and reliable as of this printing. However, we assume no responsibility for its use.

Honeywell