

ONLY FOR REFERENCE

Standard Spec Sheet

Mitsumi Model Name	STI-055A24AX
Mitsumi Model No.	R 66 8002
Operating Force	2.4N
Pcs/Reel	25,000

This specification is only for reference. If you have any questions for the details, please contact SW engineering division.

Any products mentioned in this catalog are subject to any modification in their appearance and others for improvements without prior notification.

For your adopting the products, the formal supply specification will be provided.

MITSUMI ELECTRIC CO.,LTD.

2-11-2, Tsurumaki, Tama-shi. Tokyo 206-8657 Japan.

SWITCH ENGINEERING SECTION

1049, Tateiwa, Iizuka-shi. Fukuoka 820-8533 Japan.

00	2008 File no.	Product specification Tactile switches STI-055A24AX		Approved Mar-13-18 SW Eng. Ogura	Checked Mar-13-18 SW Eng. Kikuchi	Drawn Mar-13-18 SW Eng. Inoue
		Customer's name —	Customer's parts no. —	General specification S66-1825	Issued Mar-13-18	

- 1) The items specified in this Product specification are prior to General specification.
- 2) The items not specified in this Product specification, General specification is applied.

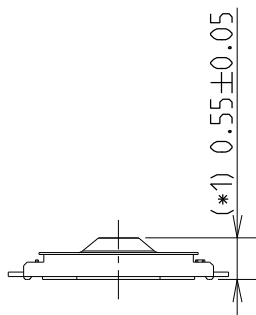
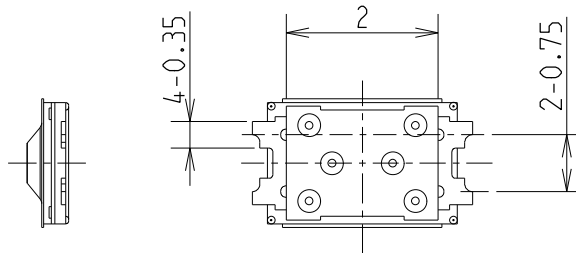
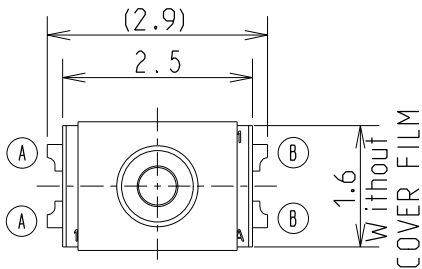

Reference solder stencil dimension

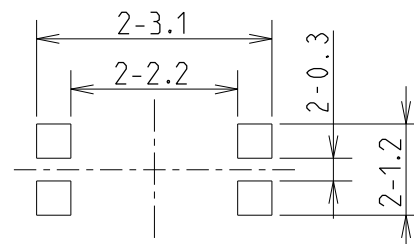

(*1)The switch height shall be measured with applying 5 gf load.

The thickness of solder stencil: 100 μm

Operating force	2.4+/-0.5 N
Return force	0.2 N min.
Click ratio	40 % min.
Travel	0.11+/-0.05 mm
Contact resistance	1 ohm max.
Max. rating	20 mA 15V DC (Resistive load)

Reference land dimension

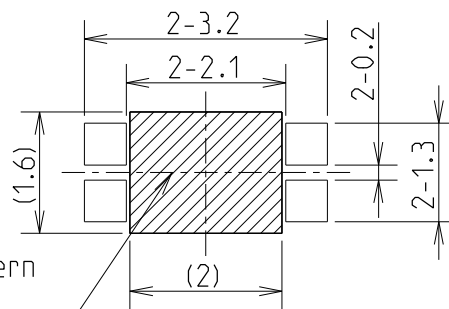

Circuit diagram

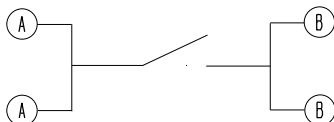

RoHS compliant (2011/65/EU)

Environmental classification	G
Parameter sheet result	N
Development class	2

Rev.				Third angle projection	Scale	Tolerance	Ass'y dwg. no.
					10:1	+/-0.15	66-K292T
QA process flow chart	Product inspection standard	Model code	Code	Indent.no.	File no.		
Q66-0856	166-8600	1556	R 66		8002 00		

5781

General Specification Tactile Switch

STI Series

APPROVED	CHECKED	WRITTEN
Mar-26-18 SW Eng. Ogura	Mar-26-18 SW Eng. Kawaguchi	Mar-26-18 SW Eng. Inoue
Mar-26-18		

1. GENERAL SCOPE

1-1 Application

This specification is applied to Tactile switches named STI series.

1-2 Operating temperature range: -10 to +60 deg-C

1-3 Storage temperature range: -25 to +85 deg-C (Product level)
-20 to +50 deg-C (Taped condition)

1-4 Test conditions

Normal temperature; 5 to 35 deg-C, normal humidity; 45 to 85% RH.

If any doubt arises from judgement, tests and measurements shall be conducted under the following conditions.

Temperature 20+/- 2deg-C, humidity 65+/-5% RH, and air pressure 86 to 106 kPa.



2. Appearance and Construction

2-1 Dimensions: Specified on Product specifications.

2-2 Materials: Refer to Table-1.

2-3 Appearance: There shall be no defects that affect the performance of the products such as crack, scratch, dirt, discoloration, air bubble of ACTUATOR, and contamination.

2-4 Cross section view:

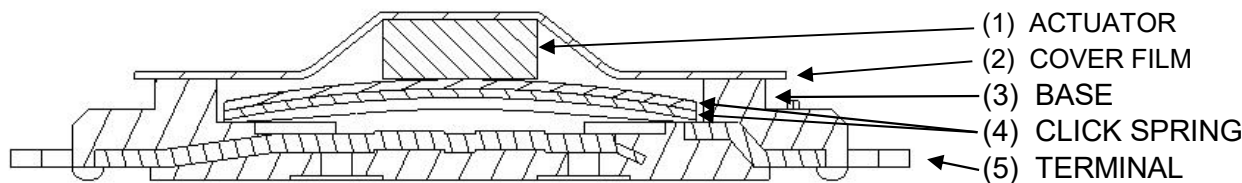

Fig-1

Table-1

Components	Material	Note
(1) ACTUATOR	9TNylon	
(2) COVER FILM	9TNylon	
(3) BASE	9TNylon	
(4) CLICK SPRING	Stainless steel	Ag plated or non-plated
(5) TERMINAL	Phosphor bronze	Ag plated

3. RATING Specified on Product specification.

Revision					Code	ID No.	File No.	
					S	66	1825	

4. ELECTRICAL CHARACTERISTICS

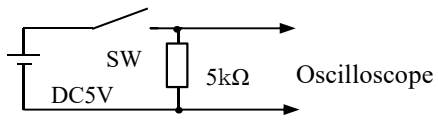
Items	Test conditions	Criteria
4-1 Contact Resistance	Placing the switch such that the direction of switch operation is vertical and applying a below static load to the operating direction, measurement shall be made. (1) Depression : 1.5 times the operating force of the standard center value (2) Measuring method : To be measured with A.C. 1kHz +/- 200Hz (Max. 20mV, 50mA) (3) Push rod shape : $\phi 2.5$, Tip : Flat, Perimeter : R0.1, Material : SUS. (Refer to Item.11 Push rod shape Fig.4)	Refer to the attached drawing. 
4-2 Insulation Resistance	Measurements shall be made following the test set force below: (1) Test voltage : 100 V DC. (2) Test time : 1minute. (3) Applied position : Between terminals.	10 M ohm min.
4-3 Withstanding Voltage	Measurements shall be made following the test set force below (1) Test voltage : 100V AC (50/60Hz) . (2) Test time : 1minute. (3) Leak current : 2mA (4) Applied position : Between terminals.	There shall be no damage and breakdown.
4-4 Bouncing	Lightly striking the actuator which is center of the switch with a press power of 1.5times of center value of operating force spec (striking speed at 2 to 3 operations per second.), bounce shall be tested at "ON" and "OFF". Push rod shape : $\phi 2.5$, Tip : Flat, Perimeter : R0.1, Material : SUS. (Refer to Item.11 Push rod shape Fig.4) 	ON bounce : 10msec. Max. OFF bounce: 10msec. Max.



5. MECHANICAL CHARACTERISTICS

Items	Test conditions	Criteria
5-1 Operating Force (OF)	Placing the switch such that the direction of switch operation is vertical and then gradually increasing the load applied to the center of the actuator, the maximum load required for the switch to come to a stop shall be measured. Push rod shape : $\phi 2.5$, Tip : Flat, Perimeter : R0.1, Material : SUS. (Refer to Item.11 Push rod shape Fig.4) The measurement shall be made just after 10 times pushing. 1) Measurement speed : 0.5 mm/s 2) Depression : 1.5 to 2 times the operating force of the specified center value	Refer to the attached drawing.
5-2 Return Force	The sample switch is installed such that the direction of switch operation is vertical and, upon depression of the Actuator in its center the whole distance, the force of the actuator to return to its free position shall be measured. Push rod shape : $\phi 2.5$, Tip : Flat, Perimeter : R0.1, Material : SUS. (Refer to Item.11 Push rod shape Fig.4) The measurement shall be made just after 10 times pushing. 1) Measurement speed : 0.5 mm/s 2) Depression : 1.5 to 2 times the operating force of the specified center value	Refer to the attached drawing.

File No.

1825

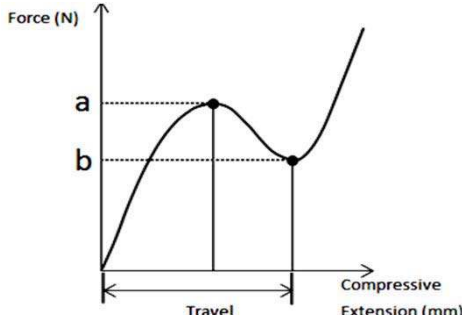
5. MECHANICAL CHARACTERISTICS

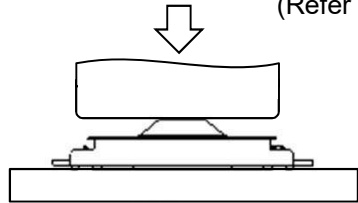
Items	Test conditions	Criteria
5-3 Click Ratio (C/R)	Calculating metrics: $C/R = ((a - b)/a) \times 100$ (%) Measurement conditions; Same as 5-1. 	Refer to the attached drawing. 
5-4 Travel	Placing the switch such that the direction of switch operation is vertical and then applying a static load to the center of the actuator, the travel distance for the switch to come to a stop shall be measured. Push rod shape : $\phi 2.5$, Tip : Flat, Perimeter : R0.1, Material : SUS. (Refer to Item.11 Push rod shape Fig.4) The measurement shall be made just after 10 times pushing. 1) Measurement speed : 0.5 mm/s 2) Depression : 1.5 to 2 times the operating force of the standard center value	Refer to the attached drawing.
5-5 Stopper Strength	Placing the switch such that the direction of switch operation is vertical and then a below static load shall be applied in the direction of stem operation. 1) Depression: 30 N 2) Time: 15 seconds 3) Push rod shape $\phi 2.5$, Tip : Flat, Perimeter : R0.1, Material : SUS. (Refer to Item.11 Push rod shape Fig.4) 	There shall be no sign of damage mechanically and electrically.
5-6 Impact Proof	Measurements shall be made following the test set forth below. 1) Acceleration: $735m/s^2$ 2) Acting time: 6 msec 3) Test direction: 6 directions 4) Cycles of test: 3 cycles per direction (18 cycles in total)	There shall be no sign of damage mechanically and electrically.
5-7 Vibration Resistance	Measurements shall be made following the test set forth below. 1) Range of oscillation: 10 to 55 Hz 2) Amplitude, pk-to-pk: 1.5 mm 3) Cycle of sweep: 10-55-10 Hz in approx. 1minute 4) Mode of sweep: Logarithmically sweep or uniform sweep 5) Direction of oscillation: Three mutually perpendicular directions, including the direction of knob travel 6) Duration of testing: 2 hours each, for a total of 6 hours	There shall be no sign of damage mechanically and electrically.

File No.

1825

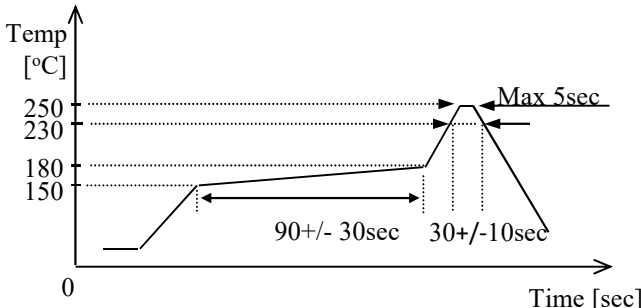
Items	Test conditions	Criteria
5-8 Solderability	Measurements shall be made following the test set force below: 1) Soldering temperature: 230 +/- 5 °C 2) Soldering time : 3 +/- 0.5 seconds 3) Solder : Sn-3.0Ag-0.5Cu 4) Soldering flux : Rosin 25%, Alcohol 75%	More than 75% of the dipped part shall be covered with solder.
5-9 Soldering heat Resistance	1) Reflow soldering 1-1) Heating method: Far-infrared heating 1-2) Temperature-time profile (Maximum value): As shown below. 1-3) Allowable soldering time: 2 times  <p style="text-align: center;">Profile of Reflow Soldering (Max)</p> <p>The condition mentioned above is a temperature on the PWB surface on which parts are mounted. There are cases where board's temperature greatly differs from switch's surface temperature, depending on board's material, size, thickness, etc. Please care, therefore, should be use not to allow switch's surface temperature to exceed 250°C.</p>	There shall be no damage on appearance. Electrical performance in Section 4 shall be assured. Operating force (Item 5-1) shall be assured.



5-10 Other precautions for soldering

- 1) Reflow soldering should be performed, due to a solder iron at manual soldering might impact huge heat on such a tiny switch product.
 In case manual soldering is performed, please be noticed that the switch is not impacted by huge heat.
- 2) Following the soldering process, do no try to clean the switch with a solvent or the like.
- 3) As the conditions vary somehow on the kind of reflow soldering equipment, please make sure you have the right one before use.
- 4) As the click ratio may deteriorate when a high heat load is applied, reflow soldering should be performed in the shortest period and at the lowest temperature possible.
- 5) Please use the proper amount of solder in order to prevent the flux penetration into the switch.
- 6) Switch terminals and PWB upper face shall be free from flux prior to soldering.
- 7) Note that if the load is applied to the terminals during soldering it might cause deformation and defects in electrical performance.

File No. **1825**

6. ENDURANCE

Items	Test conditions	Criteria
6-1 Operating life	Measurements shall be made following the test set forth below : (1) Rating load or Non-load. DC15V 20mA resistive load. (2) Rate of operation: 2 operations per second. (3) Depression: The maximum load of a specification of the operating force. (4) Cycles of operation: 200,000 cycles (5) Push rod shape: $\phi 2.5$, Tip:Flat, Perimeter:R0.1, Materials:ABS resin (Refer to Item.11 Push rod shape Fig.4)	Contact resistance:20 ohm max. Insulation resistance:10M-ohm min. Bounce: ON bounce 20 msec max. OFF bounce 20 msec max. Withstanding voltage: Item 4-3 Operating force:Assured Item 5-1 Travel: Assured Item 5-4

7. ENVIRONMENTAL

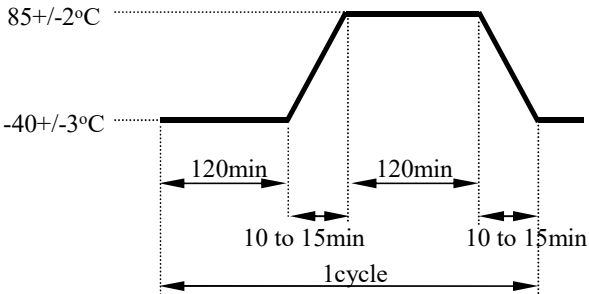
Items	Test conditions	Criteria
7-1 Humidity Resistance	After testing at $60 \pm 2^\circ\text{C}$ and 90 to 96% in relative humidity for 96 ± 5 hours, the sample is allowed to stand under normal temperature and humidity conditions within an hour, then, measurement shall be made within an hour. *Water drops shall be removed.	Contact resistance: 1 ohm max. Insulation resistance: 10M-ohm min. Bounce: ON bounce 20 msec max. OFF bounce 20 msec max. Withstanding voltage: Item 4-3 Operating force: Assured Item 5-1 Travel: Assured Item 5-4
7-2 Heat Resistance	After testing at $85 \pm 2^\circ\text{C}$ for 96 ± 5 hours, the sample is allowed to stand under normal temperature and humidity conditions within an hour, then, measurement shall be made within an hour.	
7-3 Cold Resistance	After testing at $-40 \pm 3^\circ\text{C}$ for 96 ± 5 hours, the sample is allowed to stand under normal temperature and humidity conditions within an hour, then, measurement shall be made within an hour. *Water drops shall be removed.	
7-4 Temperature Cycling	Following continuous five cycles of the temperature cycling test set forth below: 	
7-5 Water resistance IPX7 equivalent	Ingress shall be confirmed after the test under the following conditions based on IPX7. 1) Depth of immersion: 1 m 2) Duration of immersion: 30 min.	There shall be no ingress water inside of the product.
7-6 Dust protection IP6X equivalent	Ingress shall be confirmed after the test under the following conditions based on IP6X. 1) Temperature: 15 to 35 deg-C(Normal temperature) Humidity: 25 to 75% RH(Normal humidity) 2) Air pressure 86 to 106 kPa. 3) Amount of tar: 2 kg/m^3 , Tarc:JIS Z8901-4 4) Time: 8hours	There shall be no ingress dust inside of the product.

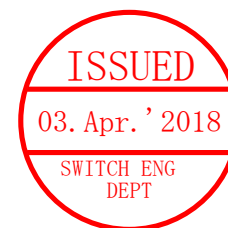

File No.

1825

8. USE CONDITIONS

8-1 Operating temperature range: -10 to 60°C(Temperature range which switch is electrically ON and OFF).

8-2 Using Environment

- 1) Do not expose the switch to corrosive gas such as sulfur gas, and salty wind.
- 2) Visible dust must be cleared.
- 3) As the switch may deform and change its quality, please do not apply excessive force to the switch.

9. STORAGE CONDITIONS

9-1 Storage temperature: -25 to 85°C. No freeze and condensation.

9-2 Using Environment

- 1) Do not expose the switch to corrosive gas such as sulfur gas, and salty wind.
- 2) Visible dust must be cleared.
- 3) As the switch may deform and change its quality, please do not apply excessive force to the switch.

9-3 Storage Method

- 1) Store the switches in the following condition: with neither direct sunshine nor corrosive gas and in normal temperature.
- 2) Do not stack too many switches for storage. Shall be free from high temperature and high humidity.
- 3) The operating part of the switch should be free position in storage.

10. PRECAUTIONS IN USE

10-1 Do not clean the switch with a solvent or the like.

10-2 Never use the product beyond the rated current and voltage.

10-3 Do not apply excessive load to the terminals and the operating part.

10-4 Larger stress than specified and/or shock shall not be applied to the operating part.

10-5 The switch will be broken, if you give larger stress than specified while operating.

Take most care not to give both upward and downward stress to the switch when you operate it.

10-6 After mounting the switch on PWB/FPC, please do not stack too many PWB/FPC in order to avoid excessive load to the switch mounted area.

10-7 The dimensions of a pattern for mounting a printed circuit board shall refer to the recommended dimensions in the outline drawing.

10-8 If you use this product in one of the following environmental conditions, progress of sulfuration and oxidation on the contact part (silver) will be accelerated, which may cause contact failure.

Therefore, be careful about the operation environment.

1) Around a sulfurate hot spring where sulfide gas is generated.

2) In case this product is always used in a place where exhaust gas from automobiles exist.

10-9 Do not push the film of the switch with something sharp.

10-10 Please design and assemble your unit not to apply over load to the switch.

10-11 Please let us know beforehand if you use other shape of pushing rod than the shape described in Item 11

10-12 Please be careful on designing and handling especially when the switch is being built into the unit, not to add side force (static or impact) to the Actuator as shown in below, the nub may be deformed or come off.

10-12 Unless provided for otherwise, the products have been designed and manufactured for application in equipment and devices which are sold to end users in the market, including audio-visual (AV) equipment, electrical home appliances, office machines, information and communication equipment, and amusement equipment. The products are not intended for use in, and must not be used for, any application for nuclear equipment, driving equipment for aerospace or any other unauthorized use.

With the exception of the abovementioned prohibited applications, please contact an Alps sales representative and/or evaluate the total system regarding applicability for applications involving high levels of safety and liability such as medical equipment, burglar alarm equipment, disaster prevention equipment and undersea equipment.

Please also incorporate fail-safe design, protection and redundant circuitry, malfunction and redundant circuitry, malfunction protection, and/or fire protection into the complete system to ensure safety and reliability of the total system.

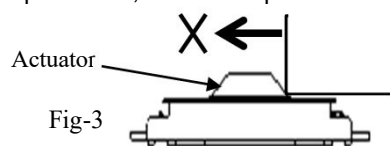
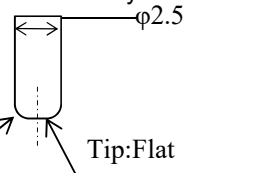

Fig-4

Primeter:R0.1

**11. Push rod shape**

Recommend the shape shown in fig-4 for the push rod.

The central axis represents the operating position of the push rod.

12. Operating Conditions

The amount of shift between the center of the switch and the central axis of the push rod Must be within 0.5mm based on the switch outline.

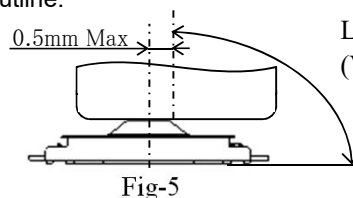

Leaning angle range : 90° +/- 2°
(Vertical direction)

File No.

1825

13. TAPE PACKING SPECIFICATION

13-1 Carrier tape dimensions are shown below.

13-2 Taping Procedure

- 1) Tape winding direction is in clockwise. (When pulling the tape toward, feeding holes should be located on the right side.)
- 2) Feeding holes shall not be covered with the cover tape. The cover tape shall not be run off the edge of the carrier tape.
- 3) Min 160 mm from the end of Trailer tape part shall be empty and min 400 mm from the end of leader tape part shall be empty. Leader part consists of the part which unstuck with cover-tape (20 to 30 mm) and the cover tape shall be extended min 300 mm.
- 4) After reeling, stick the leader part of cover tape to the side of the reel with adhesive tape (30 to 50 mm)
- 5) Peeling strength of cover-tape from carrier-tape is 0.1 to 1.3N at 165 to 180deg. angle in reverse.
- 6) Switch shall be packed in single direction.
- 7) 25,000 switches shall be pack in a reel.
- 8) The label which indicates our model number, part number, contained quantity and inspection number shall be stuck on the side of the reel.
- 9) The switch shall drop by itself when it is pushed with a force of 0.1 to 0.2 N from the back after peeling the cover tape.

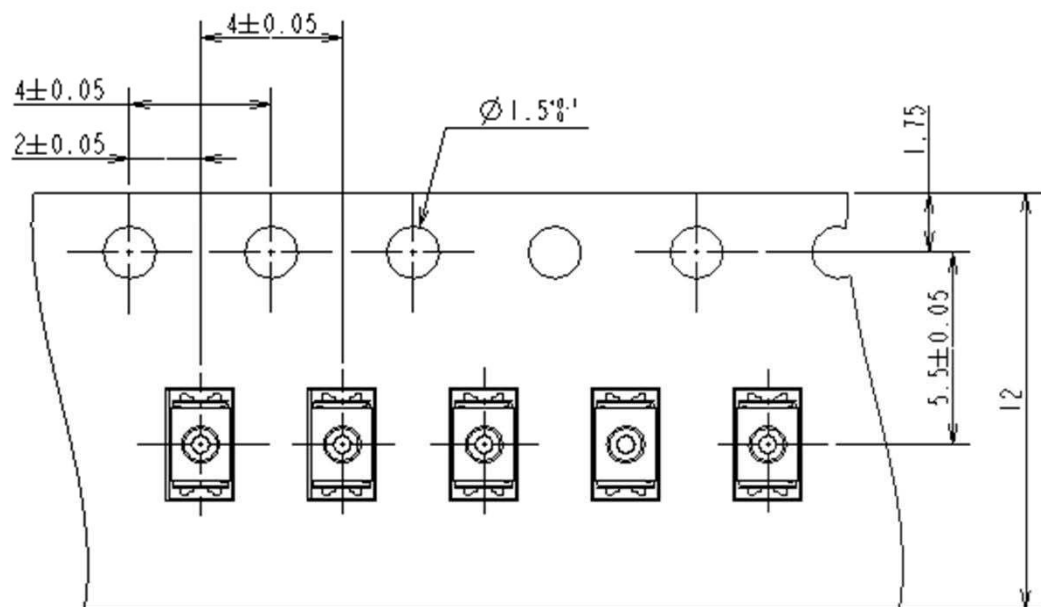
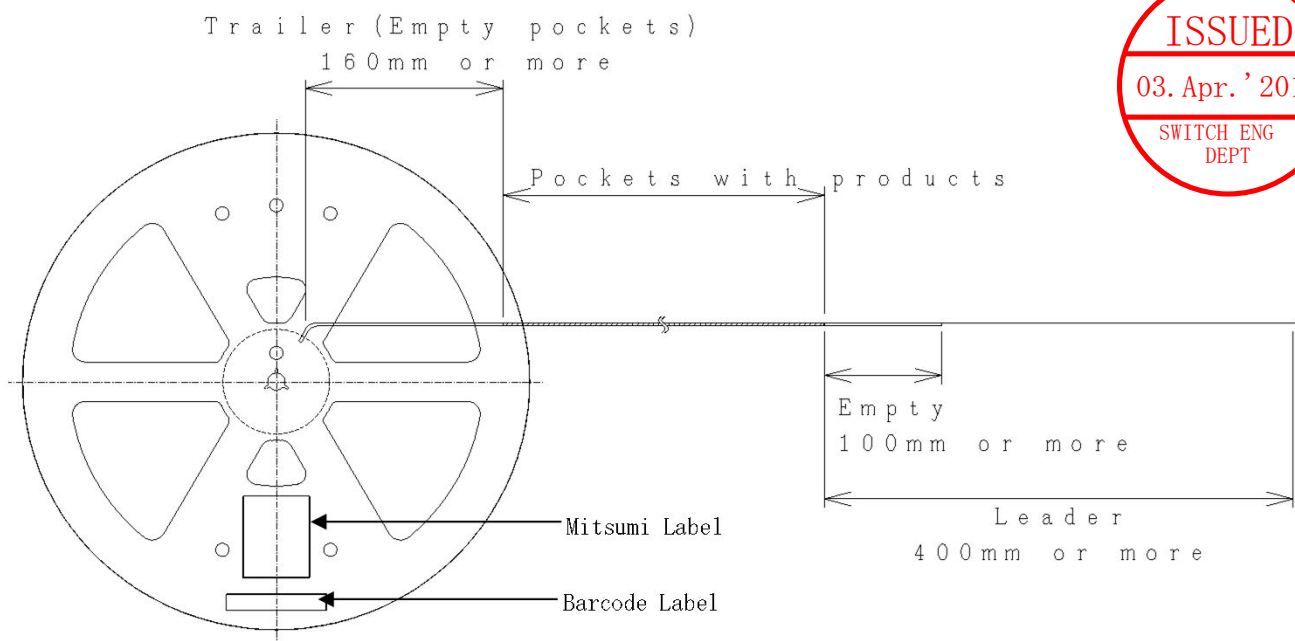

File No. **1825**

14. Packing Specification

1) Inner Package Reel

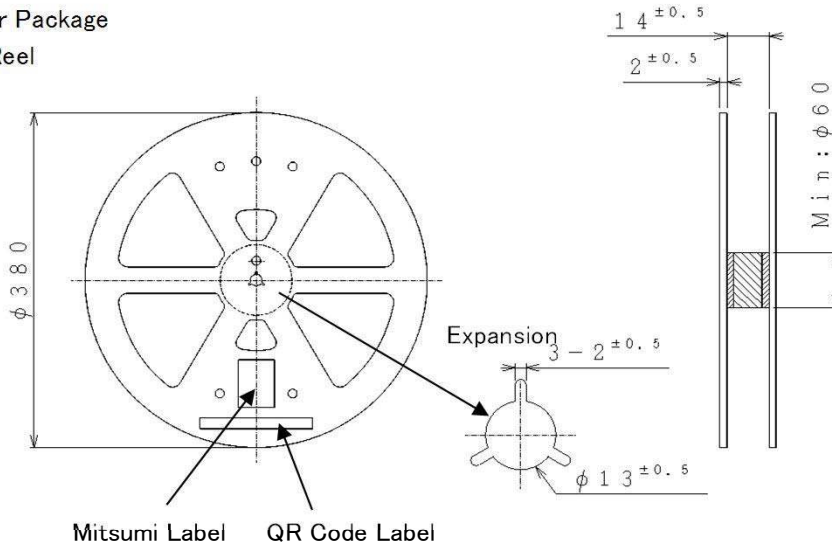

The material of a reel : PS

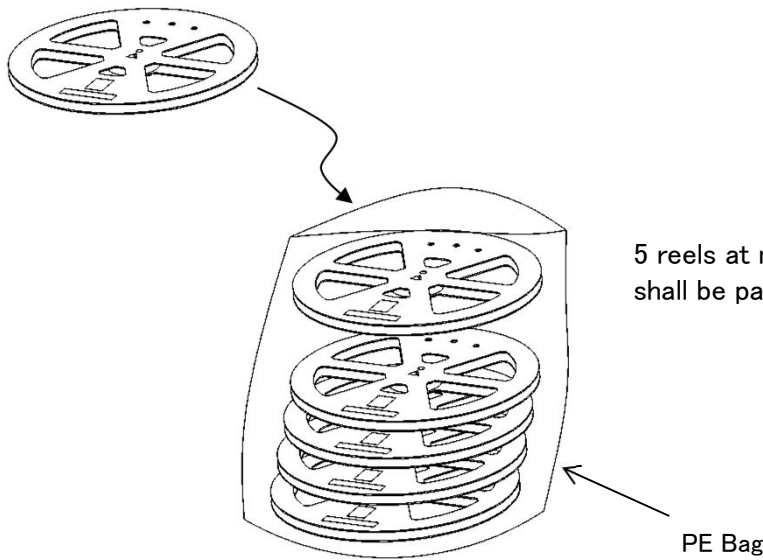

2) Outer package Outer Box

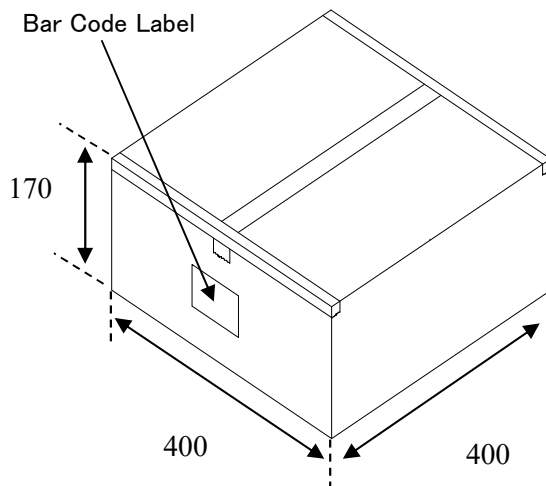

5 reels at maximum shall be packed in a outer package.

File No.

1825

3) Level

Mitsumi Label

PARTNO	*****	Customer Part No.
MODEL	STI-*****	Mitsumi Model Name
SPEC.R-	R66 **** [G]	Mitsumi Part No. G: RoHS Compliant Products
	25000 PCS	Quantity
	25000PCS CHINA	Country of Origin
	*****	Customer Part No.
	*****	Mitsumi Part No.



File No. **1825**