



All numerical values are in metric units [with U.S. customary units in brackets]. Dimensions are in millimeters [and inches]. Unless otherwise specified, dimensions have a tolerance of ± 0.13 [$\pm .005$] and angles have a tolerance of $\pm 2^\circ$. Figures and illustrations are for identification only and are not drawn to scale.

1. INTRODUCTION

This specification covers the requirements for application of AMPLIMITE Series 109 pc board connectors. These connectors are available in straight and right-angle with 9, 15, 25, 37, and 50 positions and have size 20 contact posts. Each connector features a keystone configuration mating face with a front metal shell and plastic housing and standard mounting holes that will accept removable screwlocks or commercially available hardware. The connectors include spacers that slide over the attaching hardware.

These connectors are designed for manual placement on a pc board; the connectors can also be panel mounted.

When corresponding with personnel, use the terminology provided in this specification to facilitate your inquiries for information. Basic terms and features of this product are provided in Figure 1.

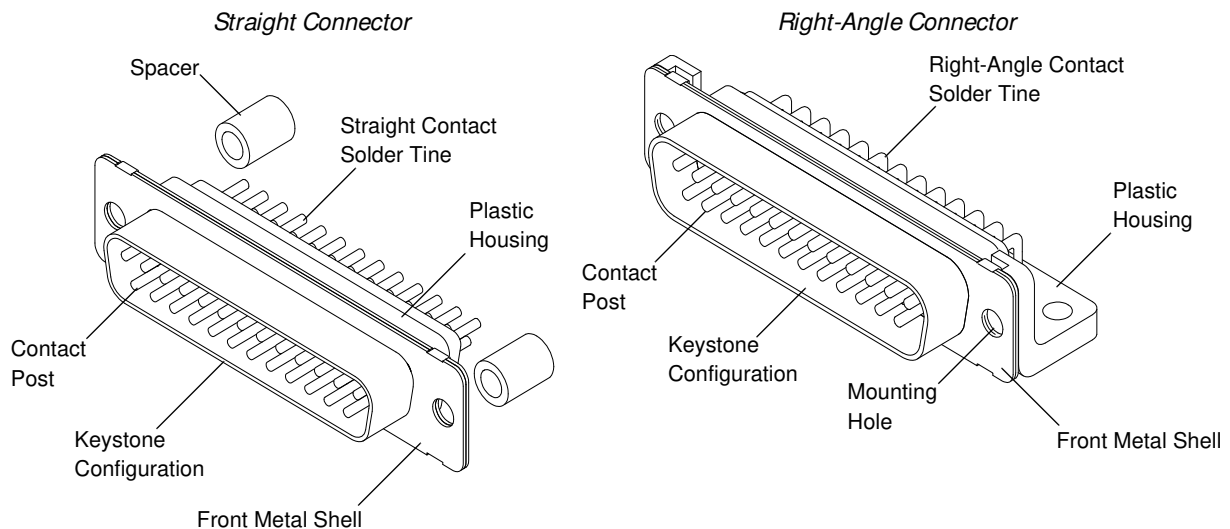

Figure 1

2. REFERENCE MATERIAL

2.1. Revision Summary

Revisions to this application specification include:

- Changed company logo
- Removed "operating" from temperature in Paragraph 3.7
- Updated application specification to corporate requirements

2.2. Customer Assistance

Reference Product Base Part Number 448693 and Product Code 4791 are representative of AMPLIMITE Series 109 pc board connectors. Use of these numbers will identify the product line and expedite your inquiries through a service network established to help you obtain product and tooling information. Such information can be obtained through a local Representative or, after purchase, by calling PRODUCT INFORMATION at the number at this page.

2.3. Drawings

Customer Drawings for product part numbers are available from the service network. If there is a conflict between the information contained in the Customer Drawings and this specification or with any other technical documentation supplied by TE Connectivity, the information contained in the Customer Drawings takes priority.

2.4. Standards and Publications

Standards and publications developed by the military provide industry test and performance requirements. Documents available which pertain to this product are:

MIL-C-24308, "Connectors, Electric, Rectangular, Nonenvironmental, Miniature, Polarized Shell, Rack and Panel"

2.5. Manuals

Manual 402-40 can be used as a guide to soldering. This manual provides information on various flux types and characteristics with the commercial designation, flux removal procedures, and a guide for information on soldering problems.

2.6. Instructional Material

Instruction Sheets (408-series) provide product assembly instructions or tooling setup and operation procedures and Customer Manuals (409-series) provide machine setup and operating procedures. There are no documents available that pertain to this product.

3. REQUIREMENTS

3.1. Connector Shell Sizes

There are five industry standard shell sizes available for these connectors. A composite of the five sizes with the overall dimension of each is provided in Figure 2.

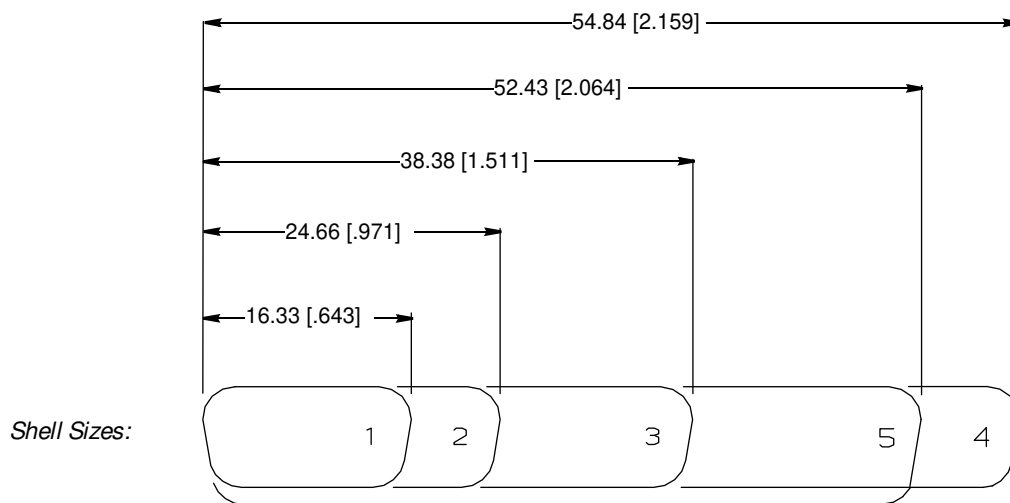

Figure 2

3.2. Shielding

The connector shell is available in either tin-plate or cadmium over steel; or cadmium or gold over brass which provide electromagnetic compatibility (EMC). When mated with another metal shell connector, both shielding and grounding continuity are achieved. Use of metallic hardware provides additional reinforcement of electrical continuity.

3.3. PC Board

A. Thickness

The connectors are designed for standard thickness pc boards of 1.57 [.062], 2.39 [.094], and 3.18 [.125]. Connectors with solder tine length range of 2.52 to 3.91 [.099 to .154] are recommended for pc boards up to 1.57 [.062] thick.

For pc board thickness up to 2.39 [.094], connectors with solder tine length range of 4.699 to 3.302 [.185 to .130], is recommended. Connectors with solder tine length range of 3.937 to 5.334 [.155 to .210] are recommended for pc boards up to 3.18 [.125] thick.

B. Solder Tine Holes

The method of drilling and plating the holes in the pc board and the size of the finished land around the holes will depend on your own established standards. The finished hole diameter after plating for the two solder tine diameters must be within the range specified in Figure 3.

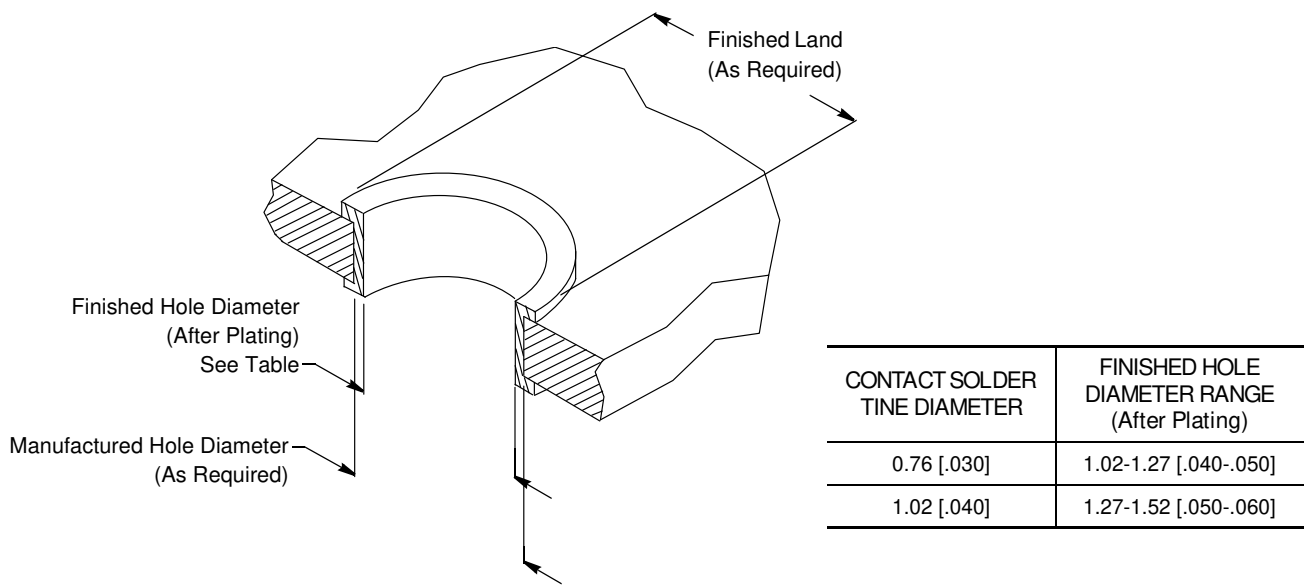
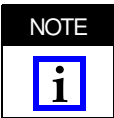

Figure 3

C. Layout

The overall pc board layout patterns for each connector shell size are provided in Figure 4.



True position tolerance for all pc board layouts is 0.25 [.010] at maximum material condition.

PC Board Layouts
(Connector Side of PC Board)

Size 1 (9-Position)

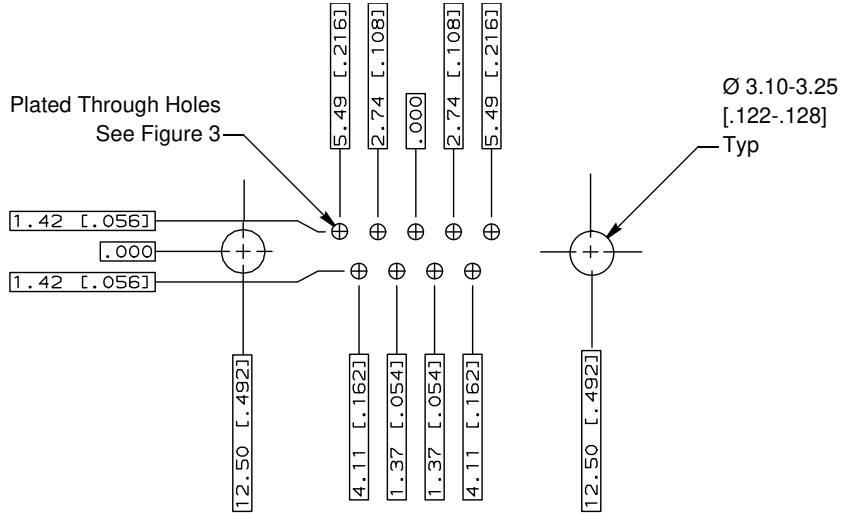

Size 2 (15-Position)

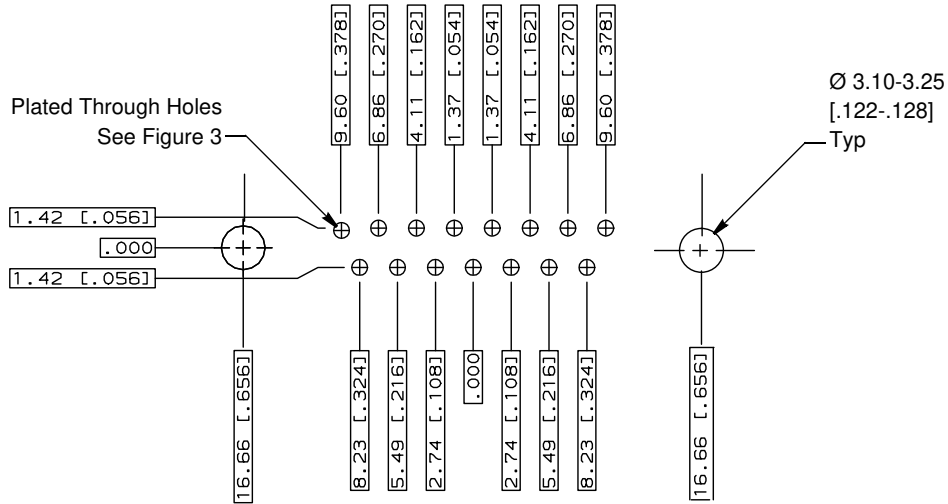

Size 3 (25-Position)

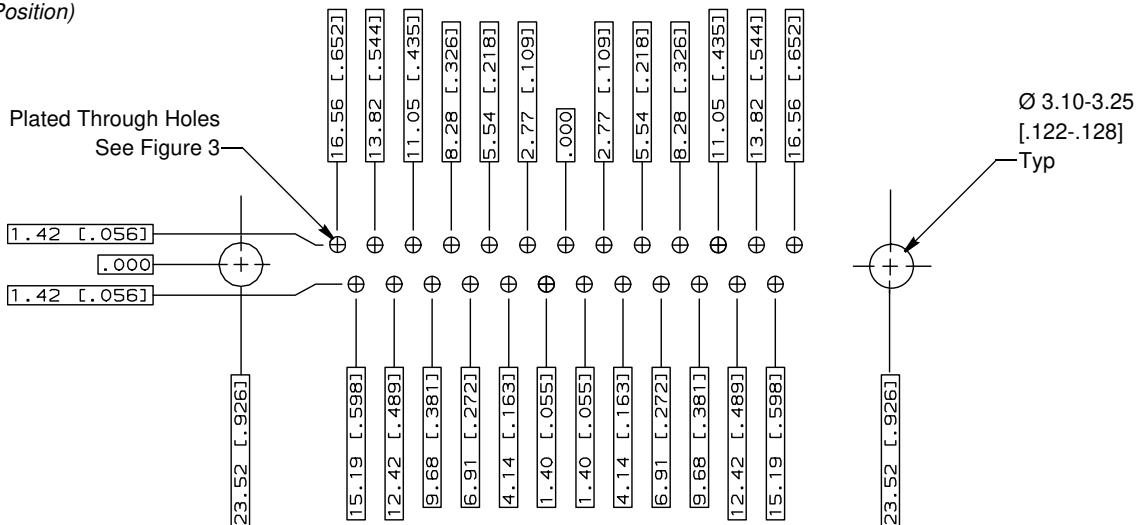
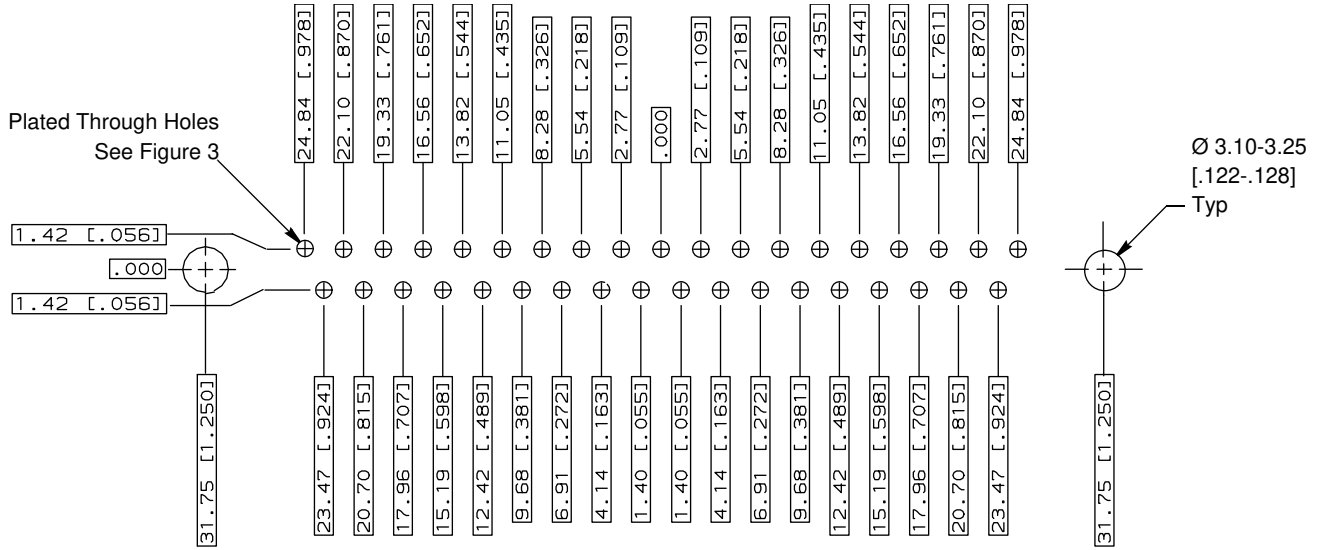

Figure 4 (Cont'd)

PC Board Layouts
(Connector Side of PC Board)

Size 4 (37-Position)



Size 5 (50-Position)

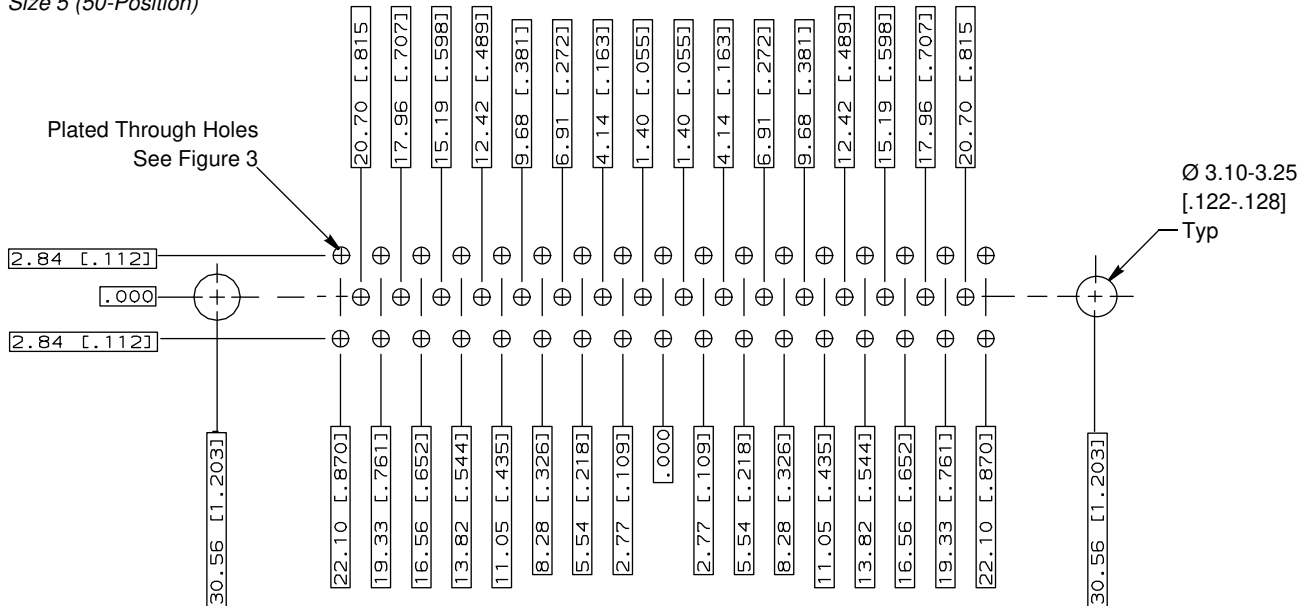

Figure 4 (End)

3.4. Connector Seating

When seated on the pc board, all contact solder tines must be through the pc board.

3.5. Panel

A. Cutout

For panel mounting, it is recommended that the connector be mounted to the rear of the panel. Cutout dimensions for proper placement in the panel are provided in Figure 5.

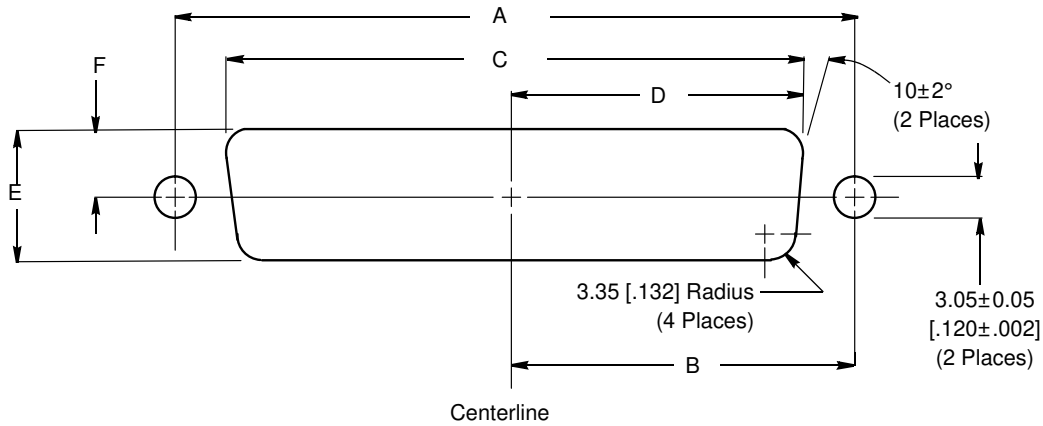

SHELL SIZE	CONTACT POSITIONS	DIMENSION					
		A	B	C	D	E	F
1	9	24.99 [.984]	12.50 [.492]	20.47 [.806]	10.24 [.403]	11.40 [.449]	5.72 [.225]
2	15	33.32 [1.312]	16.66 [.656]	28.80 [1.134]	14.40 [.567]		
3	25	47.04 [1.852]	23.52 [.926]	42.52 [1.674]	21.26 [.837]		
4	37	63.50 [2.500]	31.75 [1.250]	59.08 [2.326]	29.54 [1.163]		
5	50	61.11 [2.406]	30.56 [1.203]	56.34 [2.218]	28.17 [1.109]	14.10 [.555]	7.06 [.278]

Figure 5

B. Mounting

When mounted on the panel, the connector housing must be seated on the panel.

3.6. Mounting Hardware

Connectors can be attached to the pc board and, if used, the panel, using screwlocks or commercially available hardware. Recommended application is shown in Figure 6.

The spacer must be seated on the pc board and, if used, the panel. All hardware must be secure.

3.7. Soldering

A. Technique and Temperature

It is recommended that connectors be soldered using wave solder or equivalent soldering technique. The connectors will withstand a temperature range of -55 to 125°C [-67 to 257°F].

B. Guidelines

When soldering board-to-board applications, it is recommended the connector mating face be masked or shrouded during soldering and subsequent cleaning. This minimizes any effect this process has on the lubricity of the contact finish and therefore, mating and unmating forces. Hand soldering and cleaning may be used to control this effect.

Mounting Hardware

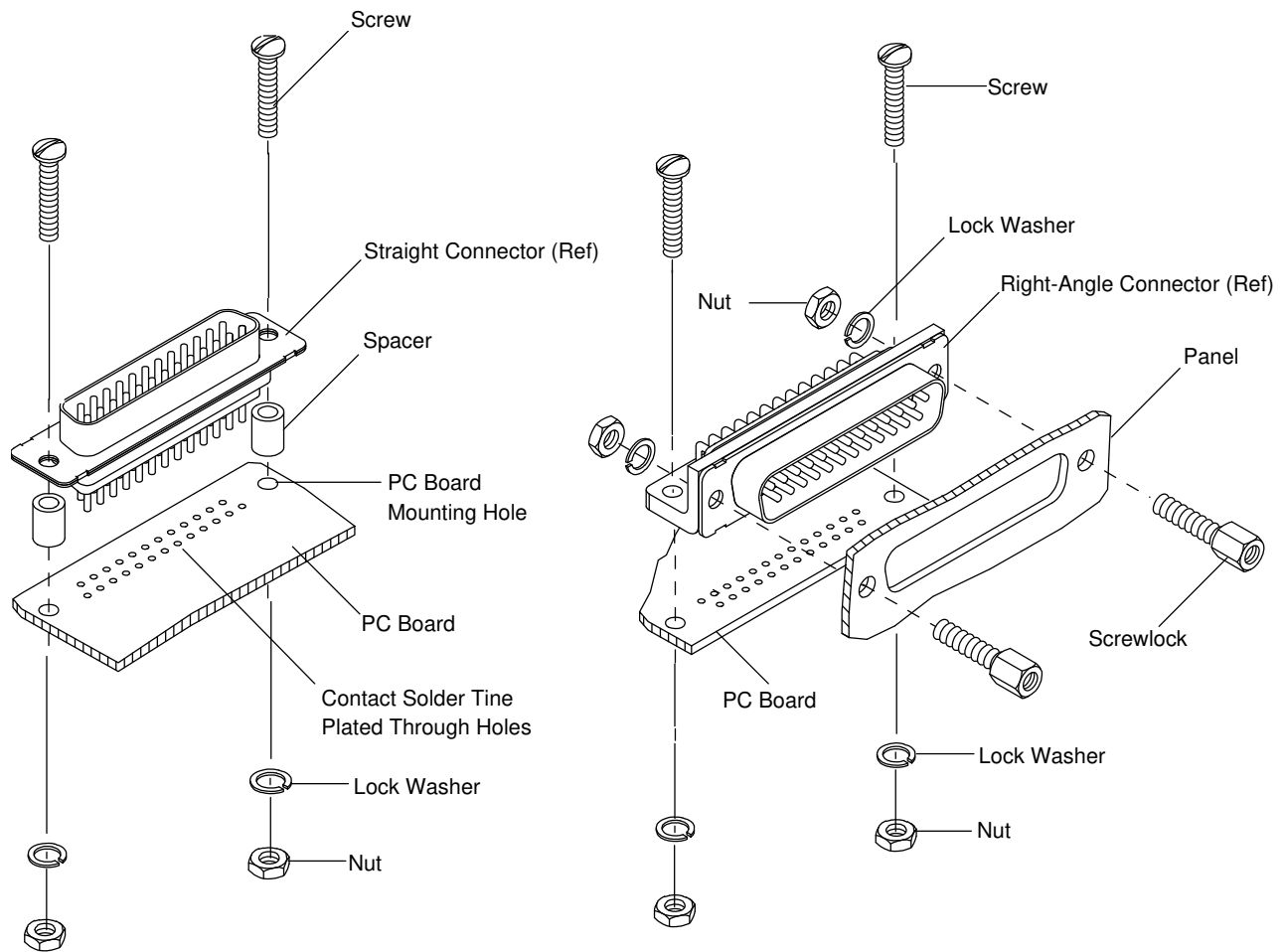

Figure 6

C. Flux

If the contact solder tines and mounting hardware are used on the trace side of the pc board, they must be fluxed prior to soldering with a rosin base flux. Selection of the proper flux will depend on the type of pc board and other components that may be mounted to the pc board, compatibility with the wave solder line, and safety requirements.

D. Cleaning

After soldering, removal of fluxes, residues, and activators is necessary. Consult with the supplier of the solder and flux for recommended cleaning solvents. Common cleaning solvents and exposure limits that should not have any adverse affect on the connectors are provided in Figure 7.



Due to the many variables involved with soldering processes (e.g., component density, orientation, fluxes, cleaners, etc), we recommend conducting trial runs under actual manufacturing conditions to ensure product and process compatibility.



Consideration must be given to toxicity and other safety requirements recommended in the Material Safety Data Sheet (MSDS) supplied by the manufacturer.

CLEANER		TIME (Minutes)	TEMPERATURE (Maximum)
NAME	TYPE		
ALPHA 2110	Aqueous	1	132°C [270°F]
KESTER 5778	Aqueous	5	100°C [212°F]
KESTER 5779			
LONCOTERGE 520			
LONCOTERGE 530			

ALPHA, KESTER, and LONCOTERGE are trademarks of their respective owners.

Figure 7

E. Drying

When drying components, make sure the temperatures are within the limitations of -55 and 125°C [-67 and 257°F]; otherwise, housing degradation could occur.

3.8. Mating

A. Polarization and Keying

The keystone configuration of the mating face prohibits the accidental inversion of mated connectors.

B. Mating Dimension

To assure full mating of connectors, the length between the mated connectors must be considered when determining panel thickness and method of mounting. Mating dimension is given in Figure 8.

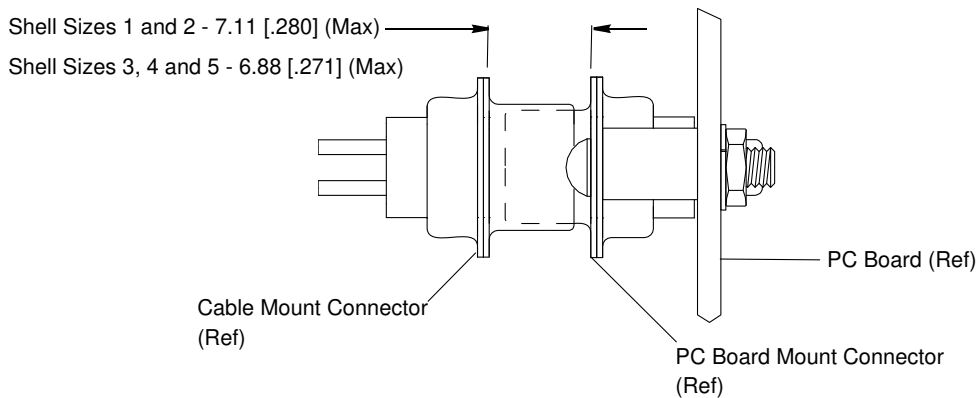

Figure 8

3.9. Repair

Damaged or defective connectors must be removed, discarded, and replaced.

4. QUALIFICATIONS

AMPLIMITE Series 109 pc board connectors are Listed by Underwriters Laboratories Inc. (UL) in File E28476 and Certified by CSA International in File LR189.

5. TOOLING

No tooling is required for the placement of these connectors onto the pc board. Appropriate tooling is need for installing hardware for attaching connectors to the pc board and mounting to a panel.

6. VISUAL AID

The illustration below shows a typical application of this product. This illustration should be used by production personnel to ensure a correctly applied product. Applications which DO NOT appear correct should be inspected using the information in the preceding pages of this specification and in the instructional material shipped with the product or tooling.

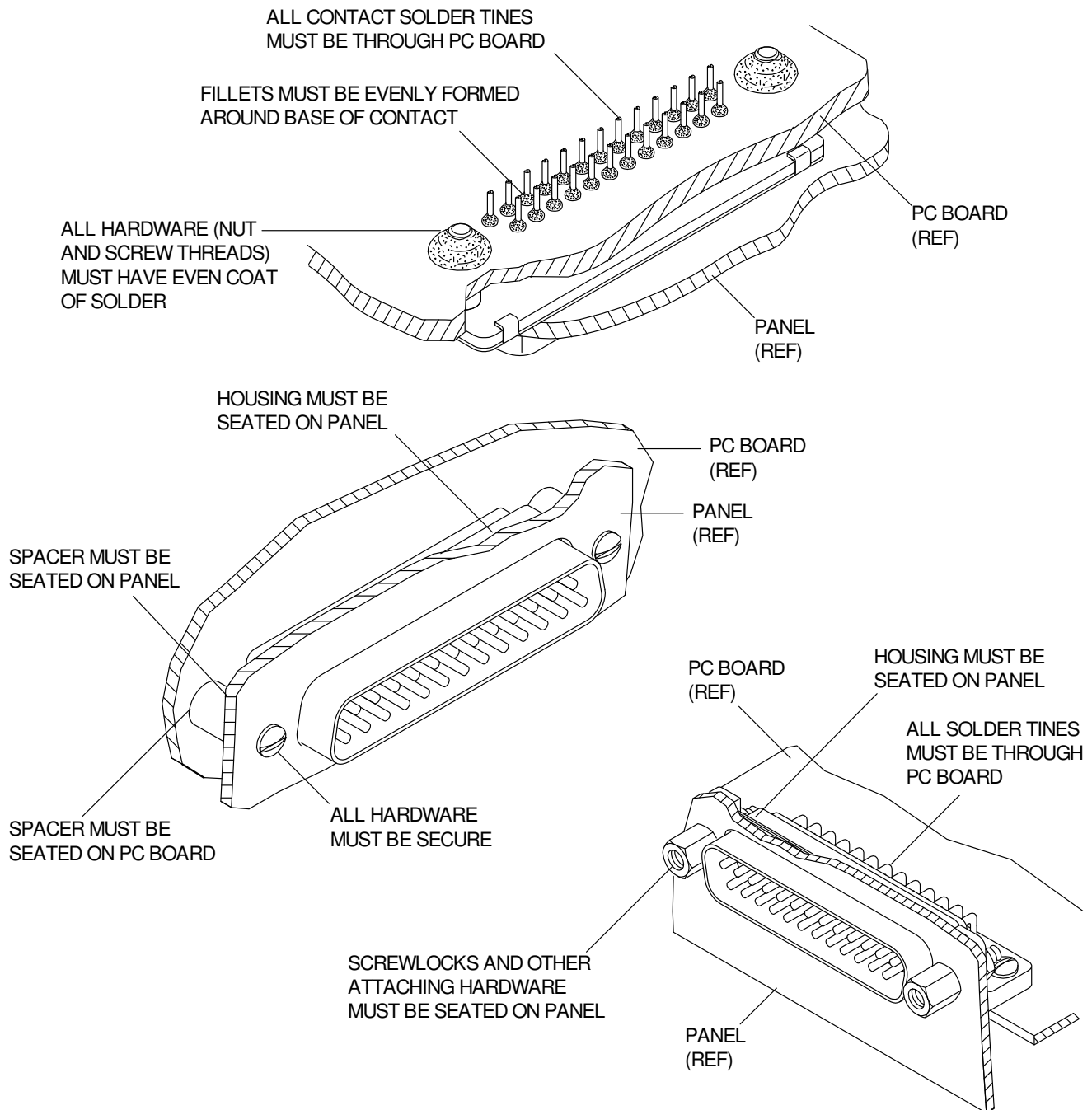

FIGURE 9. VISUAL AID