

**REVISION Z**

DO NOT SCALE FROM THIS PRINT

**NOTES:**

1.  $\text{\textcircled{C}}$  REPRESENTS A CRITICAL DIMENSION.
2. MINIMUM PUSHOUT FORCE: .5 LBS.
3. DUE TO THE HIGH AMOUNT OF INSERTION FORCE NEEDED, THE -LC OPTION IS NOT COMPATIBLE WITH AUTO PLACEMENT. SAMTEC RECOMMENDS MANUAL PLACEMENT FOR ALL ASSEMBLIES WITH THE -LC OPTION.

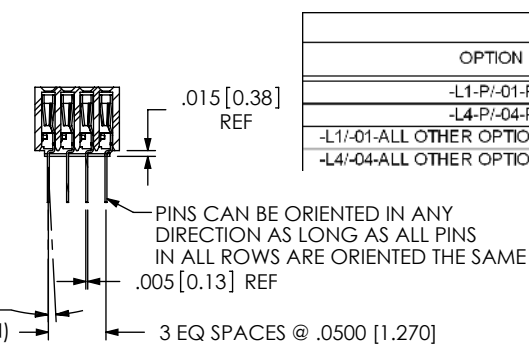
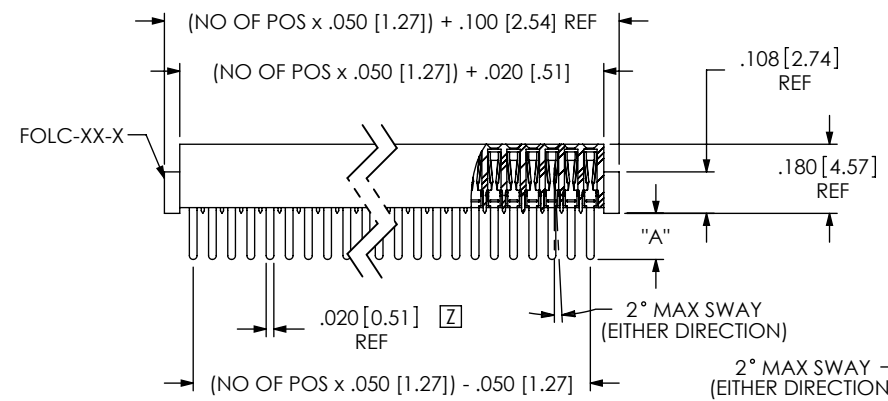
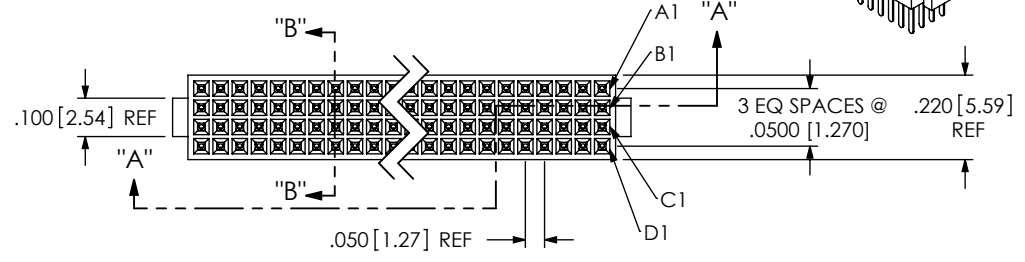
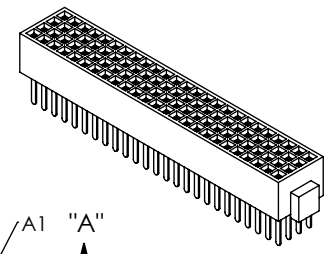

SECTION "A"-"A"

FIG 1  $\text{\textcircled{Z}}$   
FOLC-1XX-01-XX-Q SHOWN

SECTION "B"-"B"

**FOLC-1XX-XX-XX-Q-XX-X**

- No OF POSITIONS: -05 THRU -50 (PER ROW)
- LEAD STYLE:
  - 01: THROUGH HOLE (USE: C-44-03-XX)
  - L1: THROUGH HOLE (LOW INSERTION) (USE: C-61-03-XX)
  - 04: THROUGH HOLE (USE: C-44-04-XX)
  - L4: THROUGH HOLE (LOW INSERTION) (USE: C-61-04-XX)
- OPTION 2: -P: PICK & PLACE PAD (USE PPP-18) (SEE FIG 2)
- OPTION 1: -LC: LOCKING CLIP (SEE NOTE 3) (USE (2) LC-09-TM) (SEE FIG 3)
- BODY SPECIFICATION: -Q: FOUR ROW (USE FOLC-XX-Q)
- PLATING SPECIFICATION:  $\text{\textcircled{Z}}$  (VALUES GIVEN ARE IN MICRO-INCHES)
  - S: SELECTIVE, 30 Au / 50 Ni MIN ON CONTACT, MATTE TIN TAIL.
  - SM: SELECTIVE, 30 Au / 50 Ni MIN ON CONTACT, MATTE TIN TAIL.
  - L: LIGHT SELECTIVE, 10 Au / 50 Ni MIN ON CONTACT, MATTE TIN TAIL.

PACKAGING		
OPTION	TUBE	PLUG
-L1-P/-01-P	PT-1-24-06-29	TP-03
-L4-P/-04-P	PT-1-24-01-127	TP-03
-L1/-01-ALL OTHER OPTION / NO OPTIONS	PT-1-24-01-38	TP-09
-L4/-04-ALL OTHER OPTION / NO OPTIONS	PT-1-24-02-38	TP-03

TABLE 1	
LEAD STYLE	"A"
-01	.075 [1.91]
-L1	.075 [1.91]
-04	.120 [3.05]
-L4	.120 [3.05]

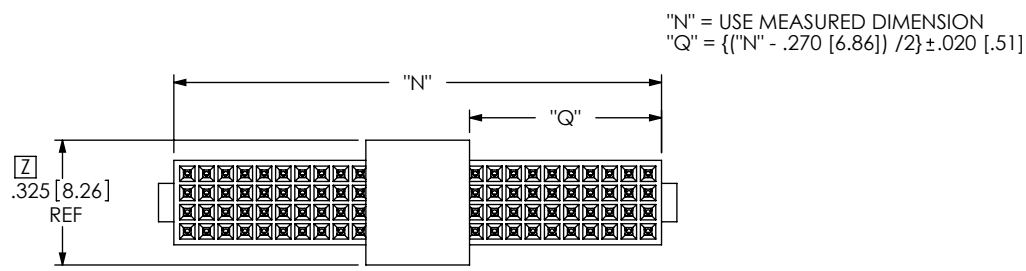

"N" = USE MEASURED DIMENSION  
"Q" =  $\{ ("N" - .270 [6.86]) / 2 \} \pm .020 [.51]$

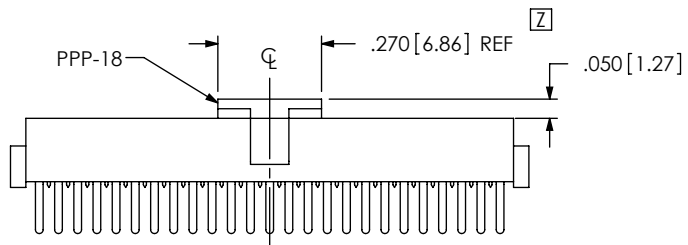

FIG 2  
-P: PICK AND PLACE PAD

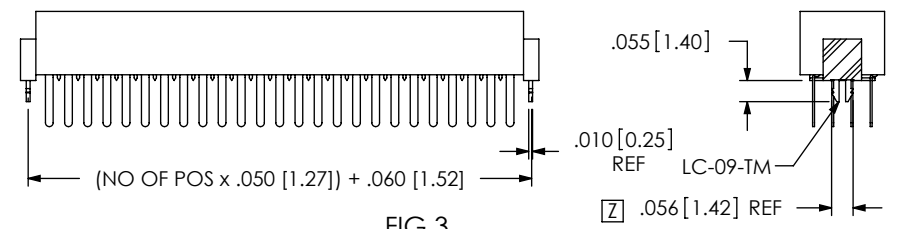

FIG 3  $\text{\textcircled{Z}}$   
-LC: OPTION  
DIFFERENT AS SHOWN, OTHERWISE SAME AS FIG 1

UNLESS OTHERWISE SPECIFIED, DIMENSIONS ARE IN INCHES. TOLERANCES ARE: DECIMALS ANGLES .XX: $\pm .01 [3]$ $5^\circ$ .XXX: $\pm .005 [13]$ .XXXX: $\pm .0020 [51]$	PROPRIETARY NOTE THIS DOCUMENT CONTAINS INFORMATION CONFIDENTIAL AND PROPRIETARY TO SAMTEC, INC. AND SHALL NOT BE REPRODUCED OR TRANSFERRED TO OTHER DOCUMENTS OR DISCLOSED TO OTHERS OR USED FOR ANY PURPOSE OTHER THAN THAT WHICH IT WAS OBTAINED WITHOUT THE EXPRESSED WRITTEN CONSENT OF SAMTEC, INC.		
		520 PARK EAST BLVD. NEW ALBANY, IN 47150 PHONE: 812-944-6733 FAX: 812-948-5047 e-Mail: info@SAMTEC.com code 55322	
MATERIAL: DO NOT SCALE DRAWING SHEET SCALE: 2:1 INSULATOR: LCP, UL 94 VO COLOR: BLACK CONTACT: BeCu		DESCRIPTION: .050 X .050 4 ROW SOCKET STRIP ASSEMBLY	
		DWG. NO. <b>FOLC-1XX-XX-XX-Q-XX-X</b>	
		BY: GREG REIDINGER 2-17-93 SHEET 1 OF 1	