

LOC	DIST	REVISIONS					
AJ	16	P	LTR	DESCRIPTION	DATE	DWN	APVD
		N1		REVISED PER ECO-11-005030	11MAR11	RK	HMR

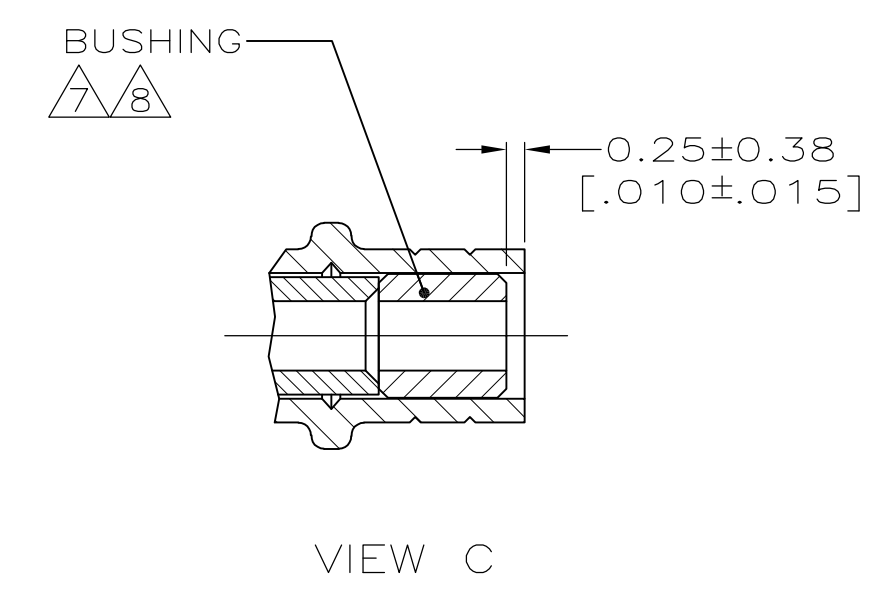
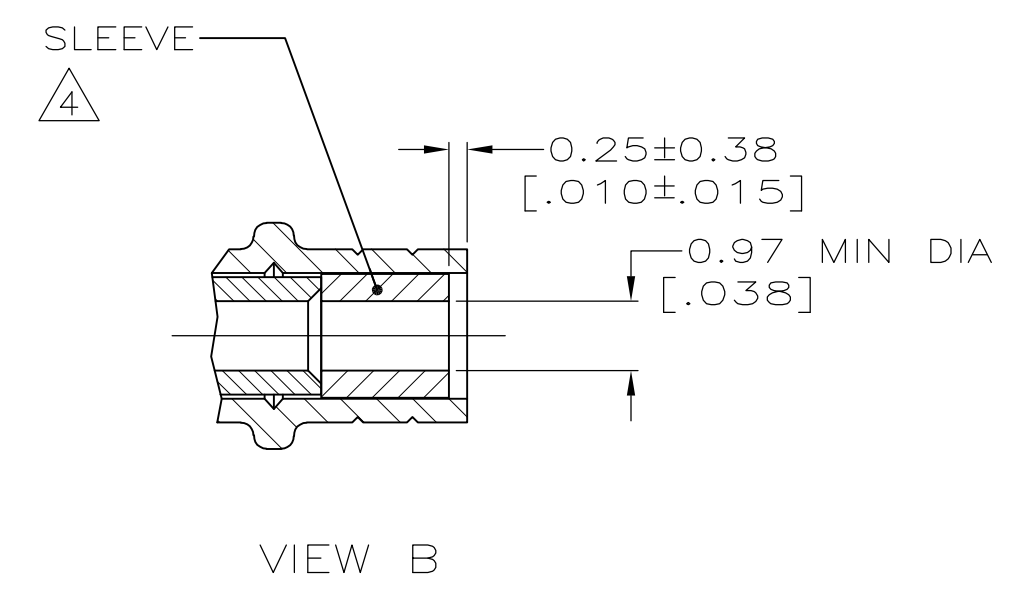
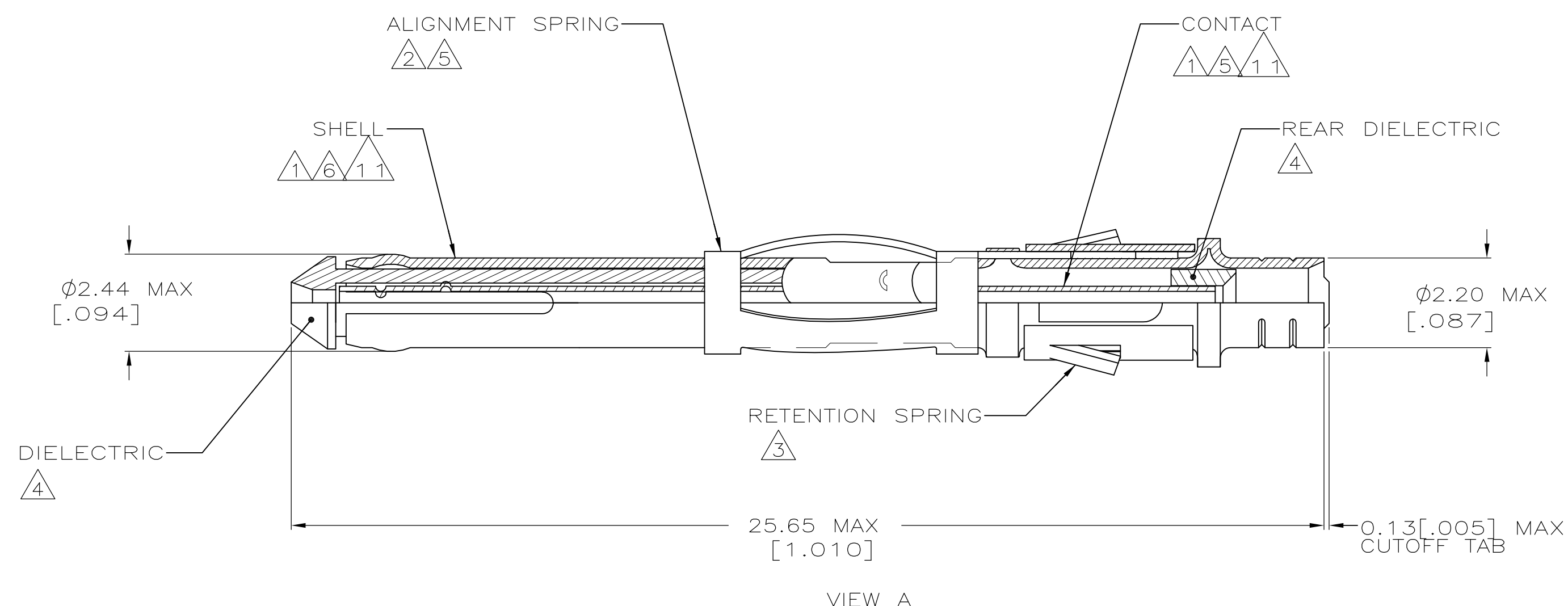

- 1 GOLD PL PER MIL-G-45204,.000030 ON MATING SURFACES, FLASH ON REMAINDER
- 2 NICKEL PL PER QQ-N-290
- 3 STAINLESS STEEL PER QQ-S-766
- 4 POLYPROPYLENE OR POLYMETHYLPENTENE GENERAL PURPOSE
- 5 BERYLLIUM COPPER PER QQ-C-533
- 6 BRASS PER MIL-C-50
- 7 BRASS PER ASTM-B-135
- 8 TIN PL PER MIL-T-10727
- 9. WEIGHT: .016 OZ
- 10. FOR CABLE SELECTION, FERRULE AND HANDTOOL PART NUMBERS, SEE I.S. 2024-2
- 11 GOLD PL PER MIL-G-45204,.000050 ON MATING SURFACES, FLASH ON REMAINDER

OBSOLETE	A	1, 2	3, 4, 5, 6	226537-7
OBSOLETE	C	1, 2, 8	3, 4, 5, 6, 7	226537-6
OBSOLETE	B	1, 2	3, 4, 5, 6	226537-5
	A	1, 2	3, 4, 5, 6	226537-4
	C	1, 2, 8	3, 4, 5, 6, 7	226537-3
	B	1, 2	3, 4, 5, 6	226537-2
	A	1, 2	3, 4, 5, 6	226537-1
VIEW	FINISH	MATERIAL	PART NUMBER	

THIS DRAWING IS A CONTROLLED DOCUMENT.		DWN S.D.KOHL 7-23-91	STE TE Connectivity	
DIMENSIONS: mm [INCHES]		CHK B. WERNER 8-1-91	PIN ASSY, SERIES SUBMINIATURE	
TOLERANCES UNLESS OTHERWISE SPECIFIED:		APVD D. DOYF 8-1-91	PRODUCT SPEC	
0 PLC ± -	1 PLC ± -	APPLICATION SPEC		
2 PLC ± -	3 PLC ± -	SIZE CAGE CODE DRAWING NO		
4 PLC ± -	ANGLES ± -	A1 00779 C-226537		
MATERIAL SEE TABLE	FINISH SEE TABLE	WEIGHT -	SCALE 10:1	SHEET 1 OF 1
CUSTOMER DRAWING		REV N1		