

REVISIONS				
P.	LTN	DESCRIPTION	DATE	OWN APVD
A		RELEASED	18JUN2018	CJV EDB
B		REVISED	12SEP2018	CJV EDB
E		REVISED PER ECO-20-002354	05DEC2019	ES SH
E1		REVISED PER ECO-20-018166	28DEC2020	ES SZ

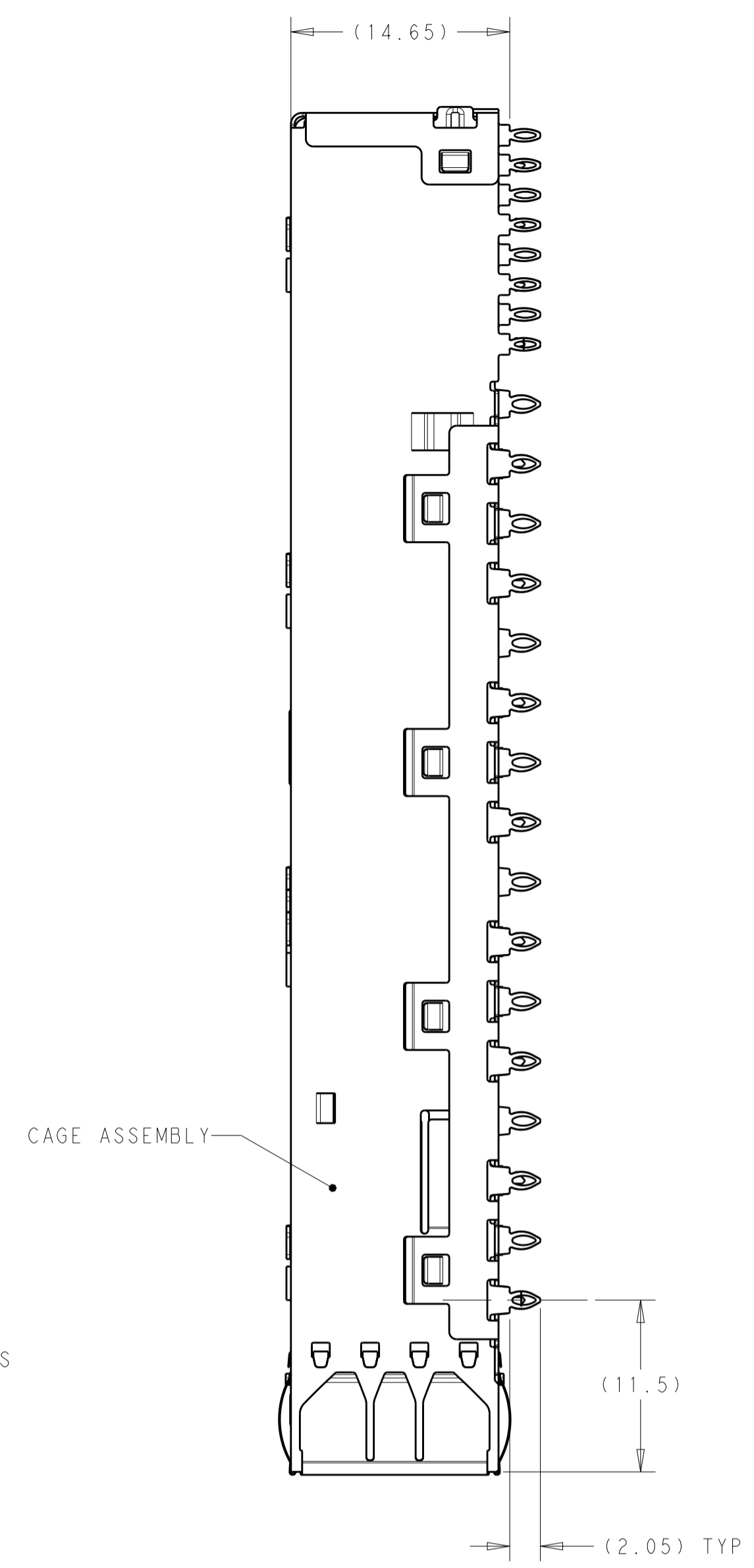

2338495-1 AS SHOWN

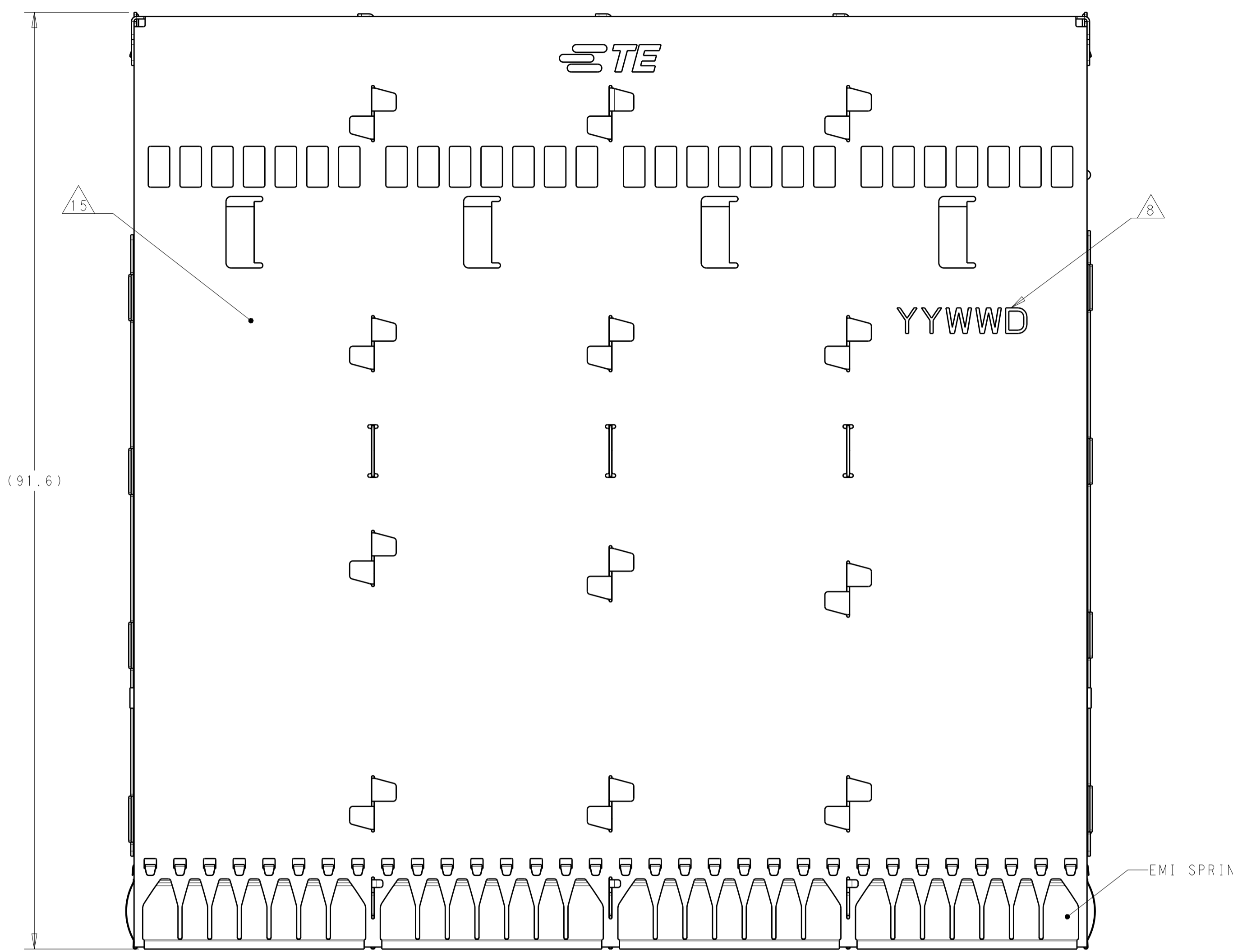
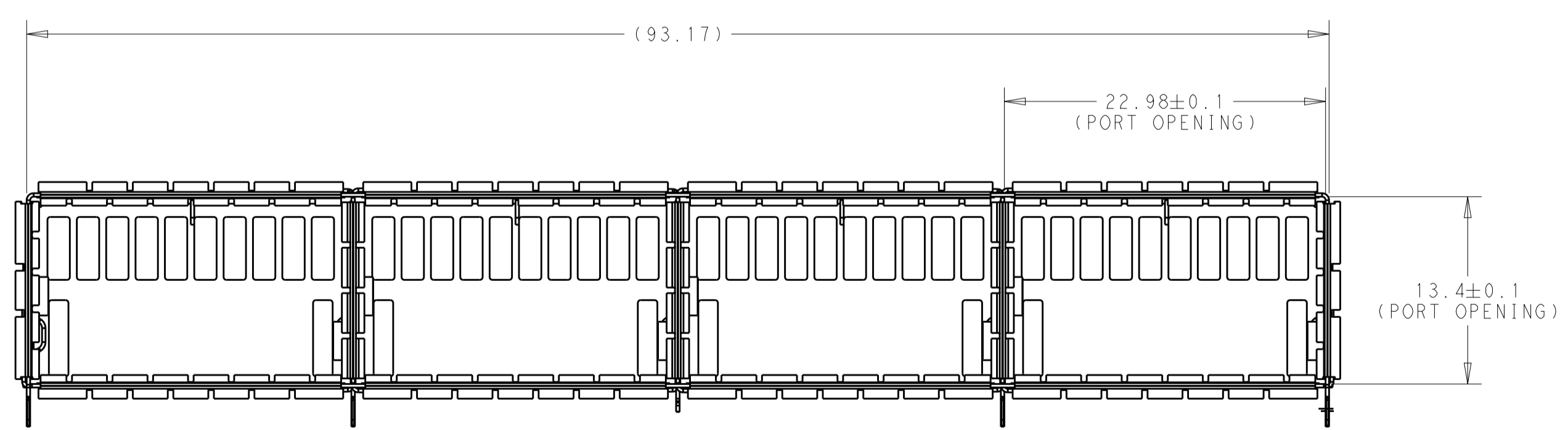

- 1 CAGE ASSEMBLY- 0.25mm THICK STAINLESS STEEL.  
EMI SPRING- COPPER ALLOY.  
LIGHT PIPE- CLEAR POLYCARBONATE.  
LIGHT PIPE ORGANIZER- POLYCARBONATE.  
LIGHT PIPE BRACKET- STAINLESS STEEL.
- 2 FINISH:  
EMI SPRING- 1.27um NICKEL PLATING OVER ALL.
- 3. MATES WITH OSFP MSA COMPLIANT TRANSCEIVERS.
- 4 DATUM AND BASIC DIMENSION ESTABLISHED BY CUSTOMER.
- 5. MINIMUM PC BOARD THICKNESS:  
SINGLE SIDE = 1.5MM  
DOUBLE SIDE = 2.10MM
- 6 PADS AND VIAS CHASSIS GROUND.
- 7 REFERENCE APPLICATION SPEC 114-XXXX, HOLE A, FOR RECOMMENDED DRILL HOLE DIAMETER AND PLATING THICKNESS.
- 8 DATE CODE MARKED IN APPROXIMATE AREA.
- 9 LIGHT PIPE ASSEMBLY SHOWN ASSEMBLED TO CAGE ASSEMBLY FOR REFERENCE. LIGHT PIPE ASSEMBLY IS SHIPPED UNASSEMBLED FROM CAGE ASSEMBLY.
- 10 LED PLACEMENT AREA FOR 4 LIGHT PIPE DASH NUMBERS.
- 11 LED PLACEMENT AREA FOR 2 LIGHT PIPE DASH NUMBERS.
- 12 LED PLACEMENT AREA FOR 1 LIGHT PIPE DASH NUMBERS.
- 13 ASSEMBLY NOT COMPATIBLE WITH LIGHT PIPES.
- 14 ASSEMBLY COMPATIBLE WITH LIGHT PIPES.
- 15 PART NUMBER MARKED IN APPROXIMATE AREA.
- 16 LOW Br/CI AS DEFINED IN TEC-138-702.
- 17 LIGHT PIPE ASSEMBLY IS SHIPPED ATTACHED TO CAGE ASSEMBLY.
- 18 PACKAGE: HARD TRAY.

CALLOUT	DESCRIPTION	PART NUMBER
2	WITH EMI SPRINGS	6-2338495-1
16	WITH EMI SPRINGS	5-2338495-3
4	WITH EMI SPRINGS	4-2338495-3
4	WITH EMI SPRINGS	4-2338495-1
2	WITH EMI SPRINGS	2-2338495-3
2	WITH EMI SPRINGS	2-2338495-1
1	WITH EMI SPRINGS	1-2338495-3
1	WITH EMI SPRINGS	1-2338495-1
18, 14	WITH EMI SPRINGS	2338495-6
14	WITH EMI SPRINGS	2338495-5
13	WITHOUT EMI SPRINGS	2338495-4
13	WITH EMI SPRINGS	2338495-3
13	WITHOUT EMI SPRINGS	2338495-2
13	WITH EMI SPRINGS	2338495-1
LIGHT PIPES PER PORT		
DESCRIPTION		PART NUMBER

THIS DRAWING IS A CONTROLLED DOCUMENT.

OWN: C. VALENTINE 18JUN2018  
 CHK: D. HARMON 18JUN2018  
 APVD: D. HARMON 18JUN2018

**STE** TE Connectivity

NAME: CAGE ASSEMBLY, 1X4, OSFP  
 PRODUCT SPEC: 108-60117  
 APPLICATION SPEC: 114-130009

SIZE: A1 CAGE CODE: - DRAWING NO: -  
 WEIGHT: -  
 RESTRICTED TO: -

CUSTOMER DRAWING SCALE: 3:1 SHEET 1 OF 8 REV: E1

REVISIONS				
P.	LTN	DESCRIPTION	DATE	APVD
-	-	SEE SHEET 1	-	-

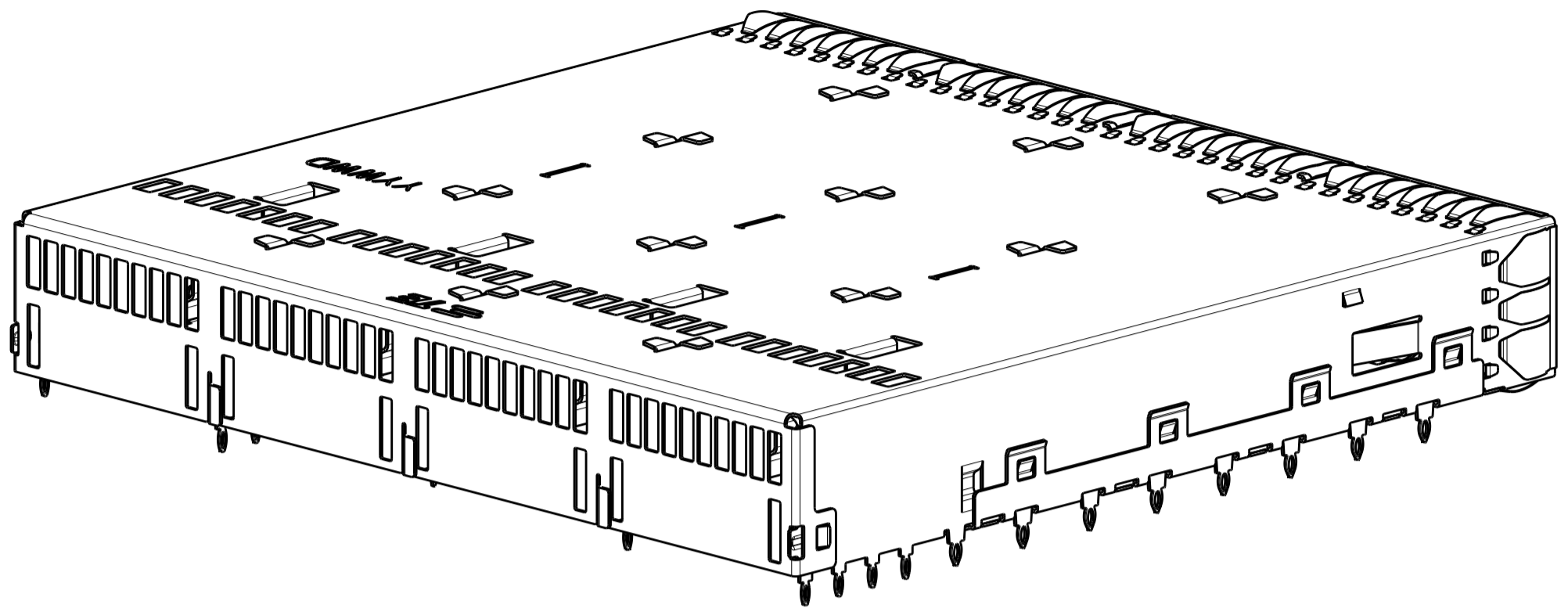

2338495-1  
SCALE 2:1

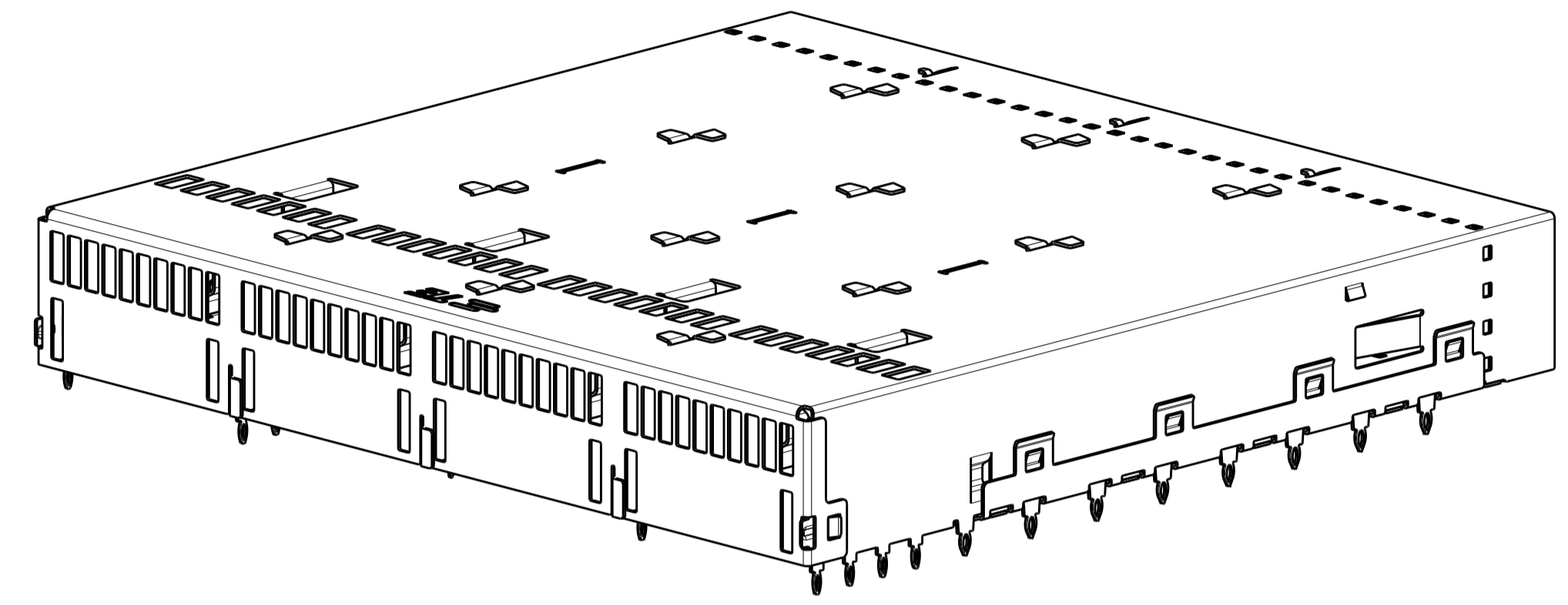

2338495-2  
SCALE 2:1

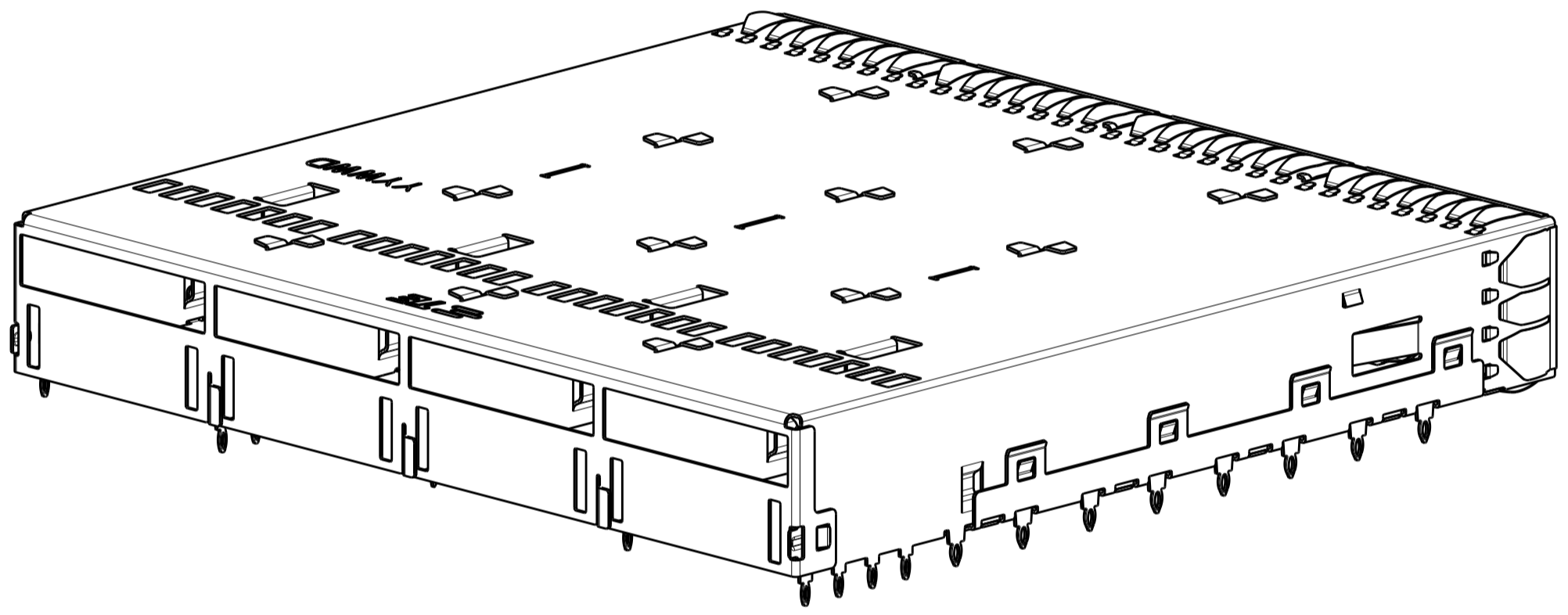

2338495-3  
SCALE 2:1

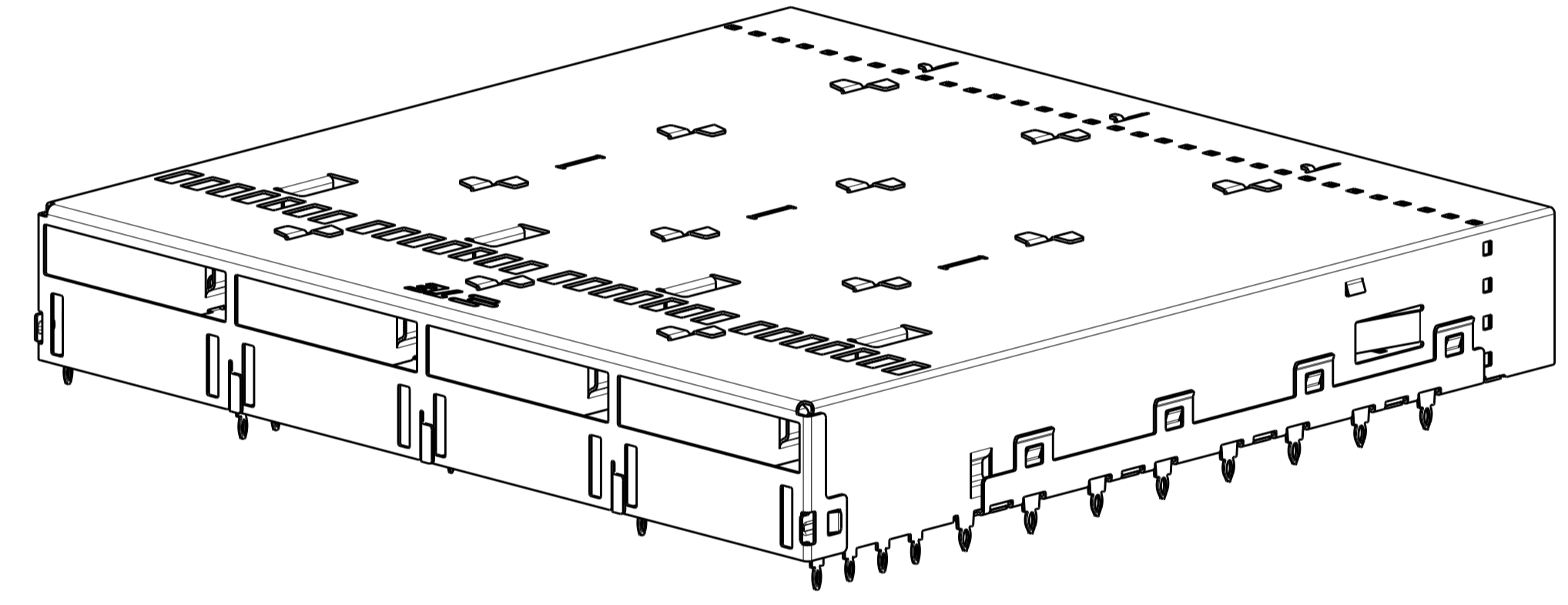

2338495-4  
SCALE 2:1

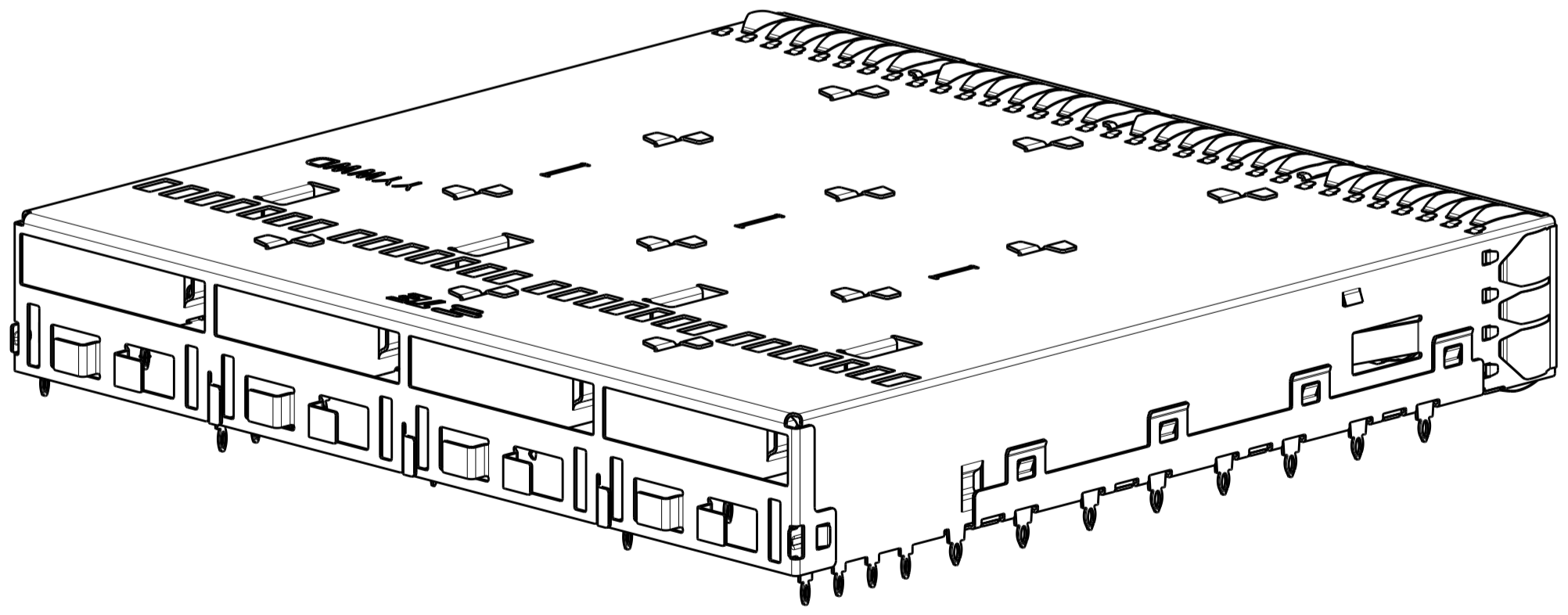

2338495-5 AND 2338495-6  
SCALE 2:1

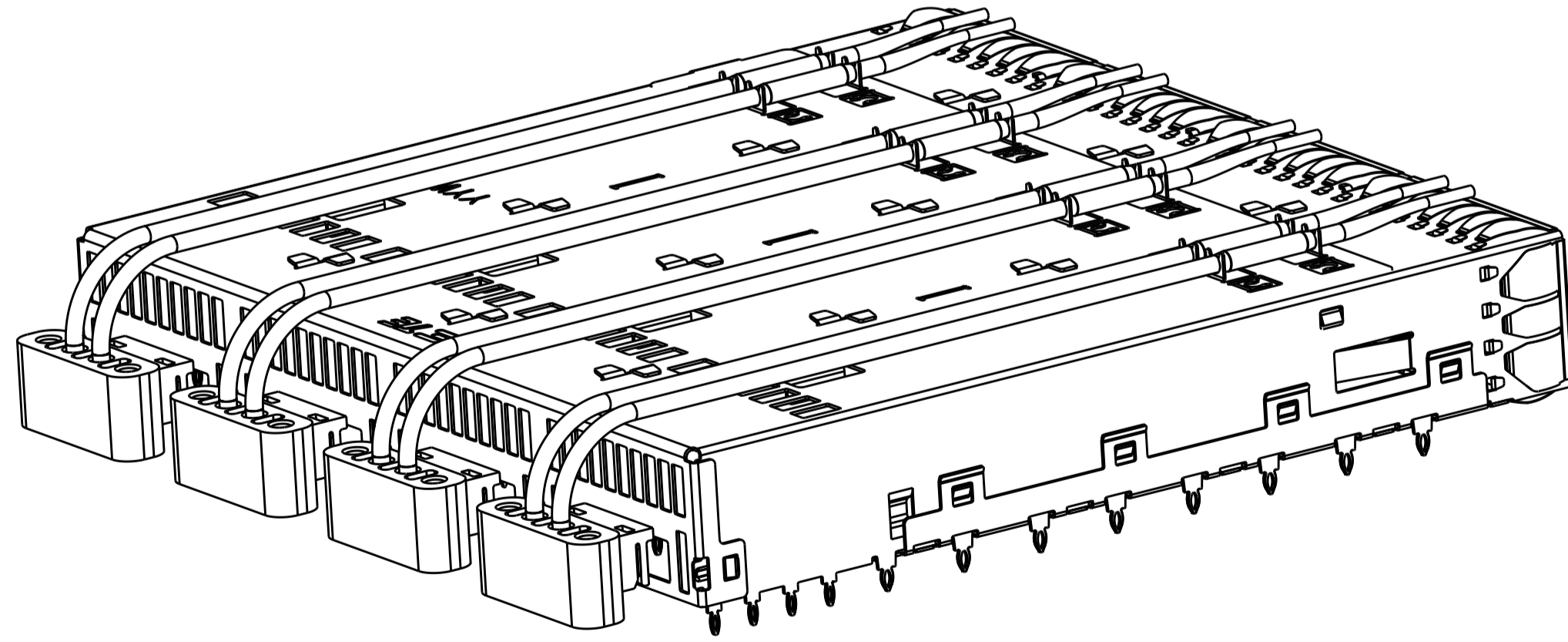

6-2338495-1  
SCALE 2:1

THIS DRAWING IS A CONTROLLED DOCUMENT.		DWN C. VALENTINE 18JUN2018 CHK D. HARMON 18JUN2018 APVD D. HARMON 18JUN2018	
DIMENSIONS: mm	TOLERANCES UNLESS OTHERWISE SPECIFIED: 0 PLC ± 1 PLC ±0.25 2 PLC ±0.15 3 PLC ±0.10 4 PLC ± ANGLES ± FINISH	NAME CAGE ASSEMBLY, 1X4, OSFP PRODUCT SPEC 108-60117 APPLICATION SPEC 114-130009 WEIGHT CUSTOMER DRAWING	
MATERIAL		SIZE A1 CAGE CODE DRAWING NO. ©=2338495 SCALE 3:1	RESTRICTED TO SHEET 2 OF 8 REV E1

REVISIONS				
P.	LTN.	DESCRIPTION	DATE	APVD.
-	-	SEE SHEET 1	-	-

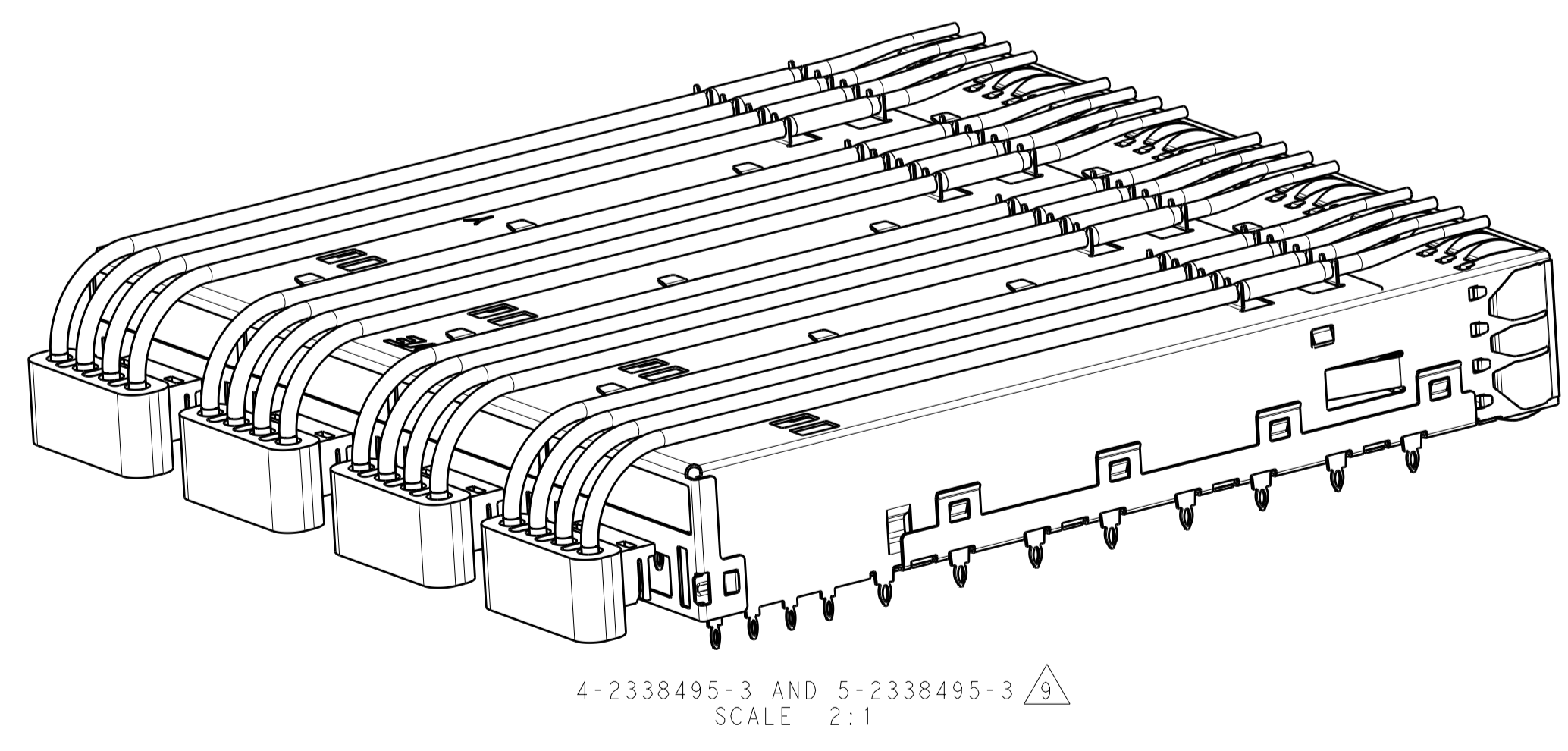
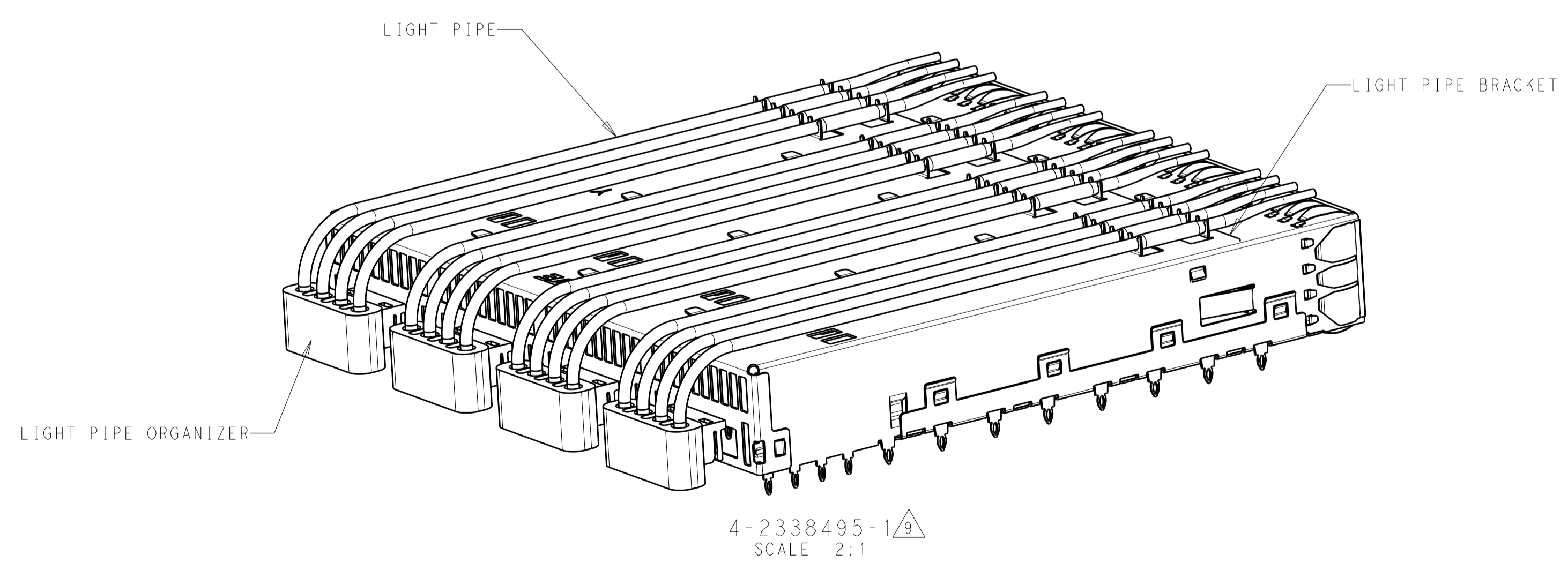
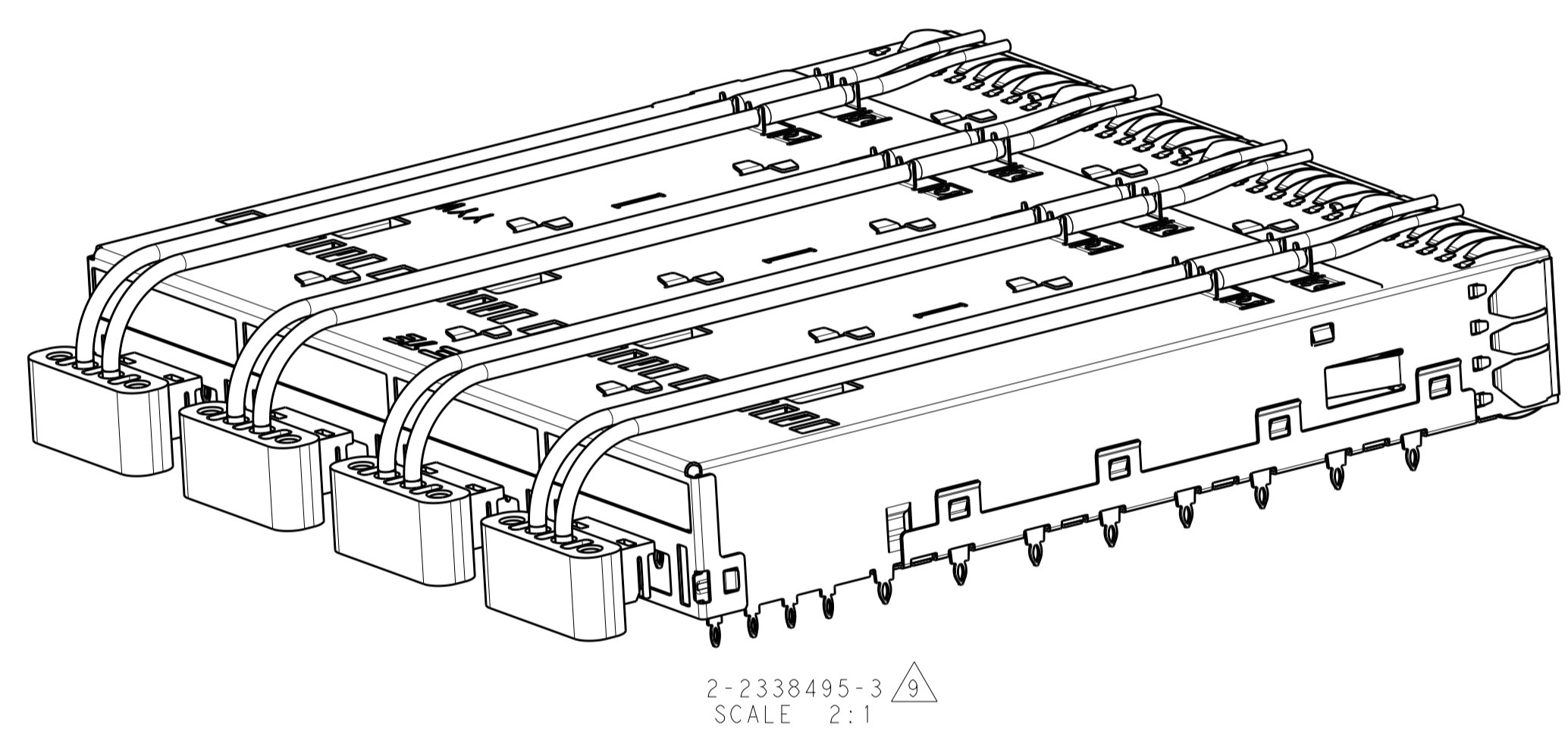
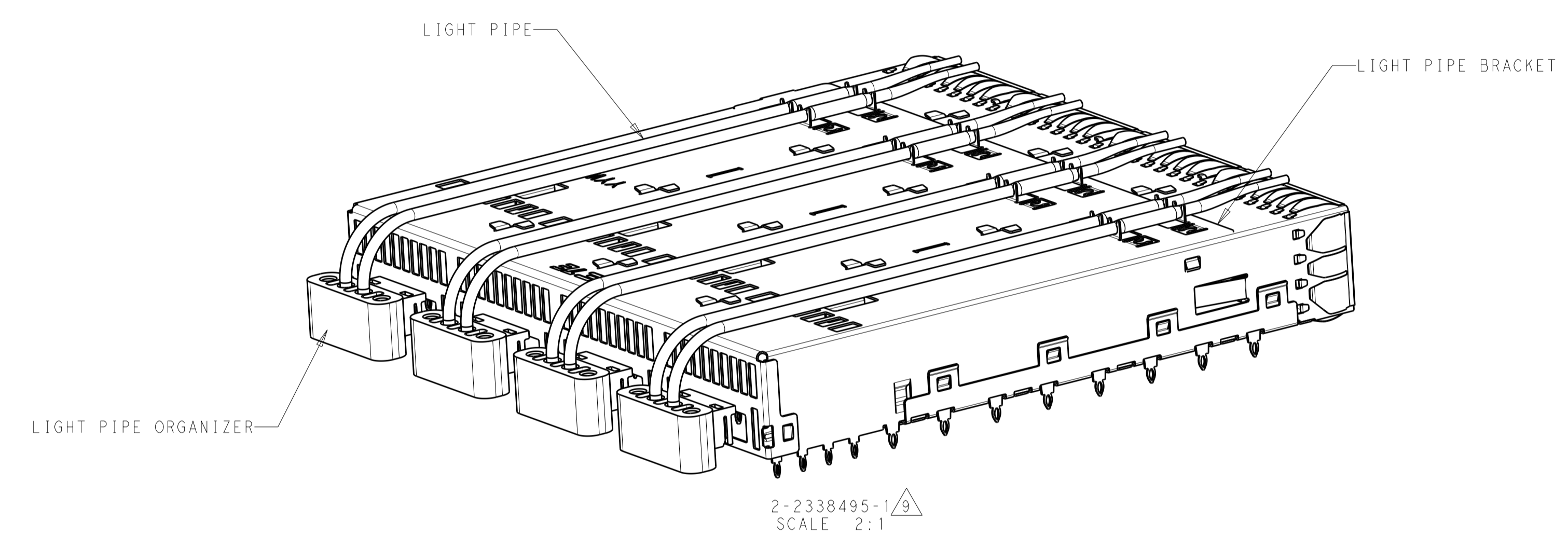
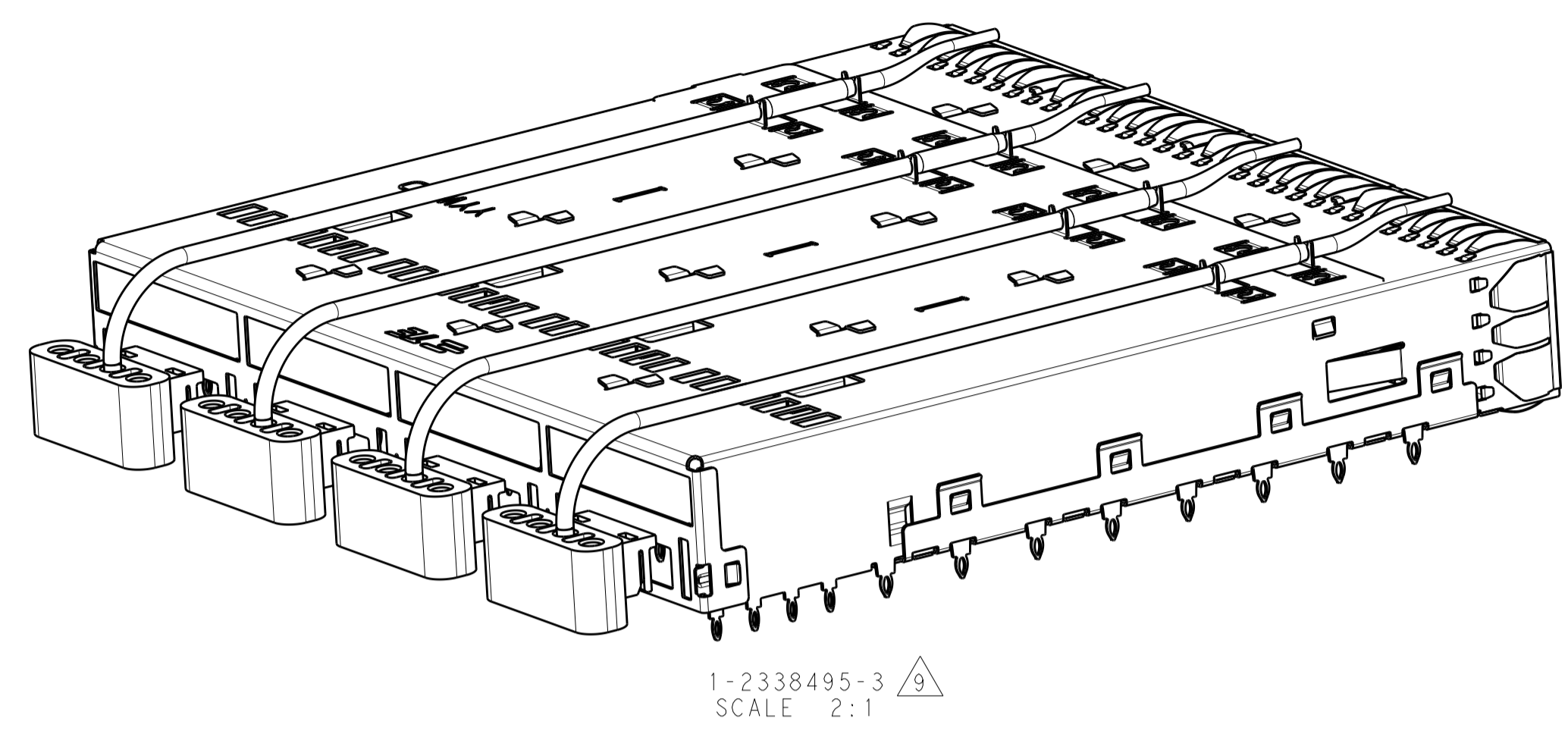
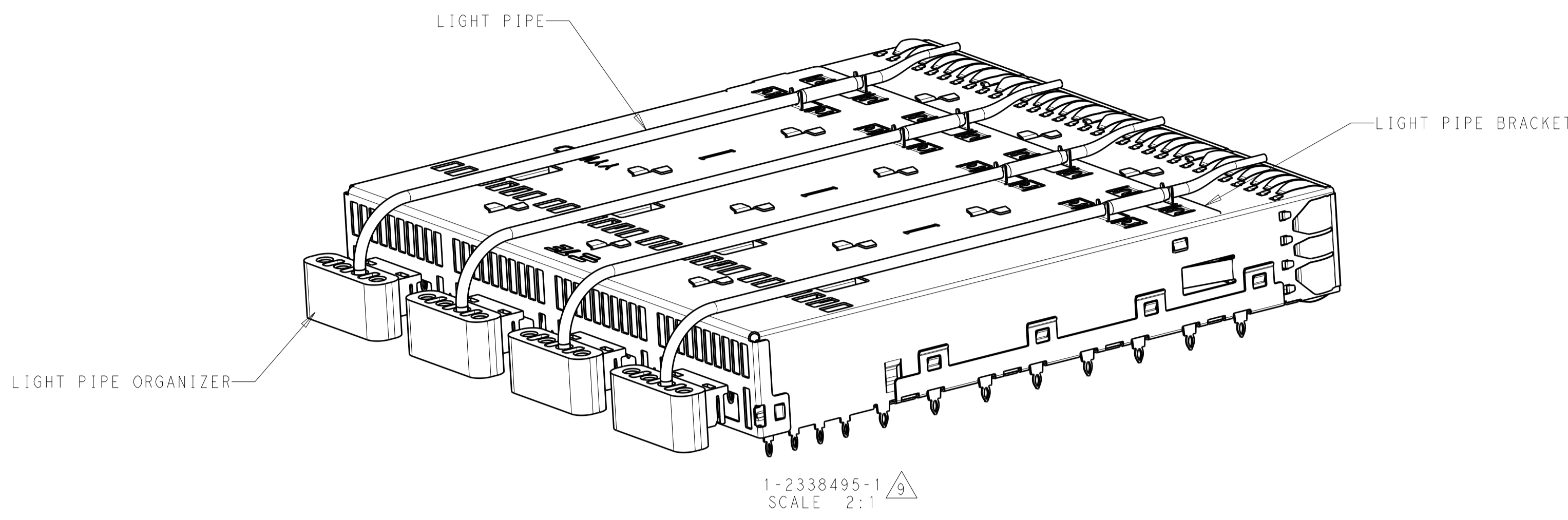

THIS DRAWING IS A CONTROLLED DOCUMENT.		OWN C. VALENTINE 18JUN2018	TE Connectivity
DIMENSIONS:		CHK D. HARMON 18JUN2018	
mm	TOLERANCES UNLESS OTHERWISE SPECIFIED:	APVD D. HARMON 18JUN2018	NAME CAGE ASSEMBLY, 1X4, OSFP
	0 PLC ± 1 PLC ±0.25 2 PLC ±0.15 3 PLC ±0.10 4 PLC ± ANGLES ±	PRODUCT SPEC 108-60117	SIZE A1
MATERIAL	FINISH	APPLICATION SPEC 114-130009	RESTRICTED TO
		WEIGHT	CAGE CODE DRAWING NO C=2338495
		CUSTOMER DRAWING	SCALE 3:1 SHEET 3 OF 8 REV E1

REVISIONS				
P.	LTN	DESCRIPTION	DATE	APVD
-	-	SEE SHEET 1	-	-

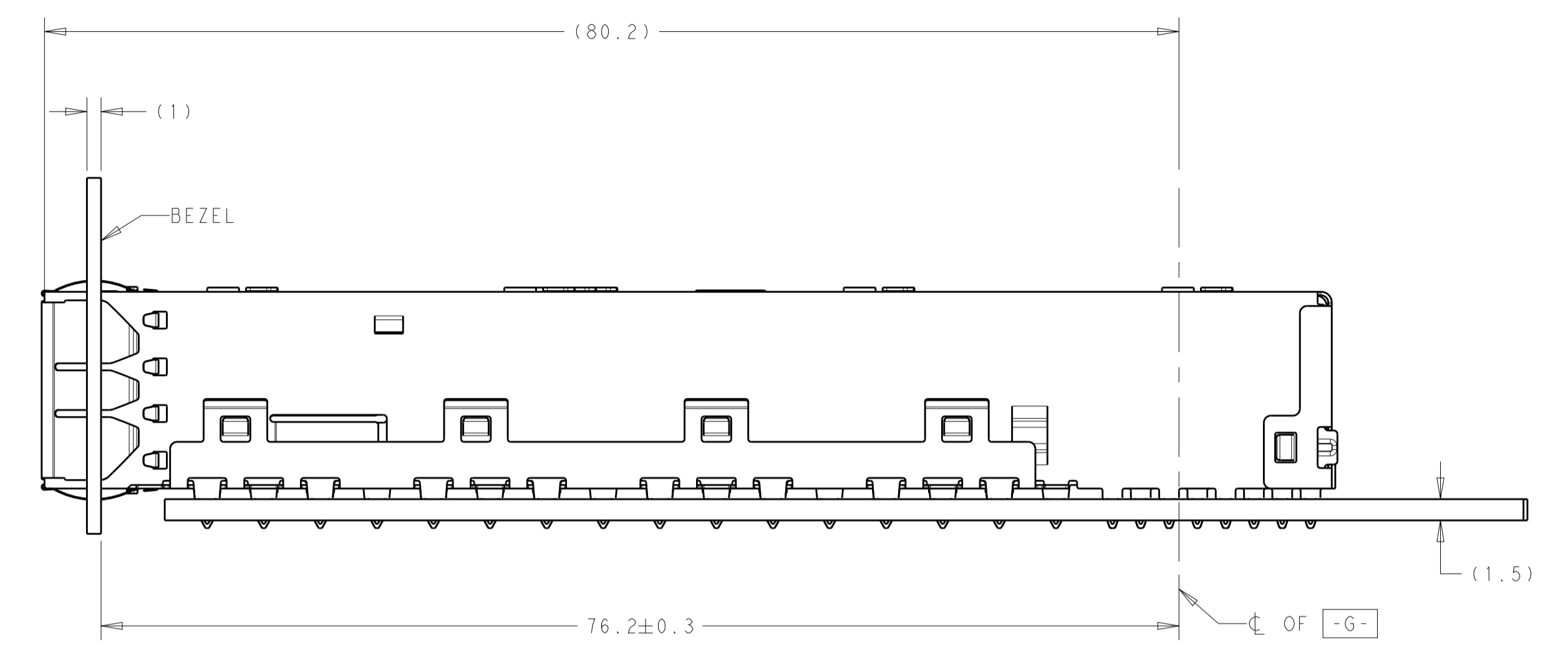
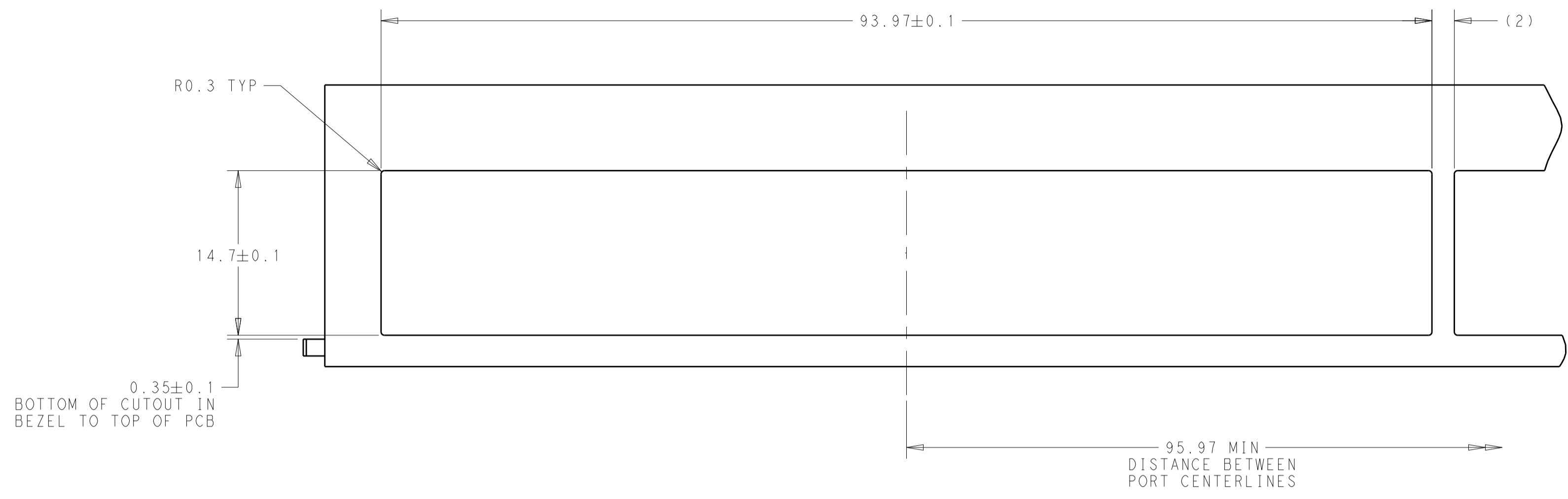

SINGLE SIDE MOUNTING

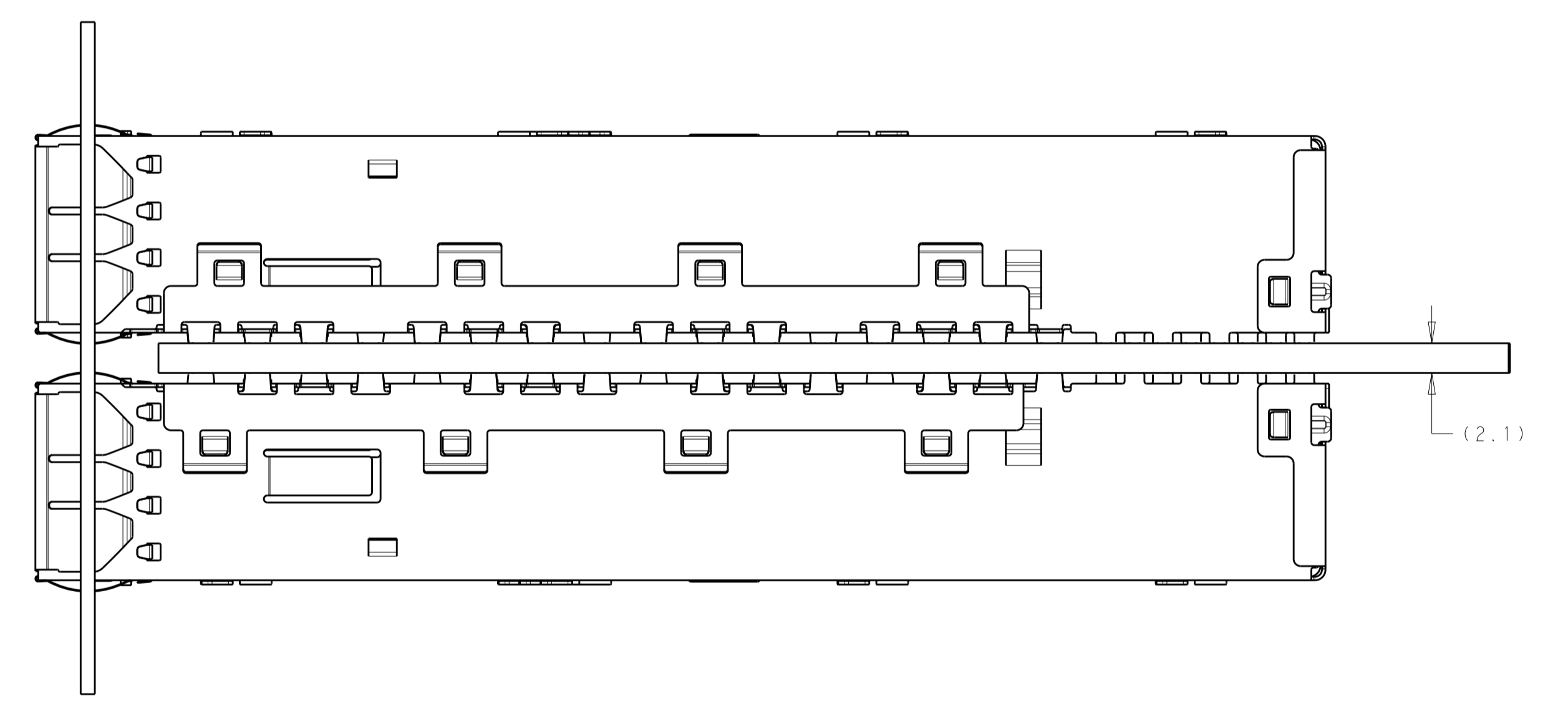
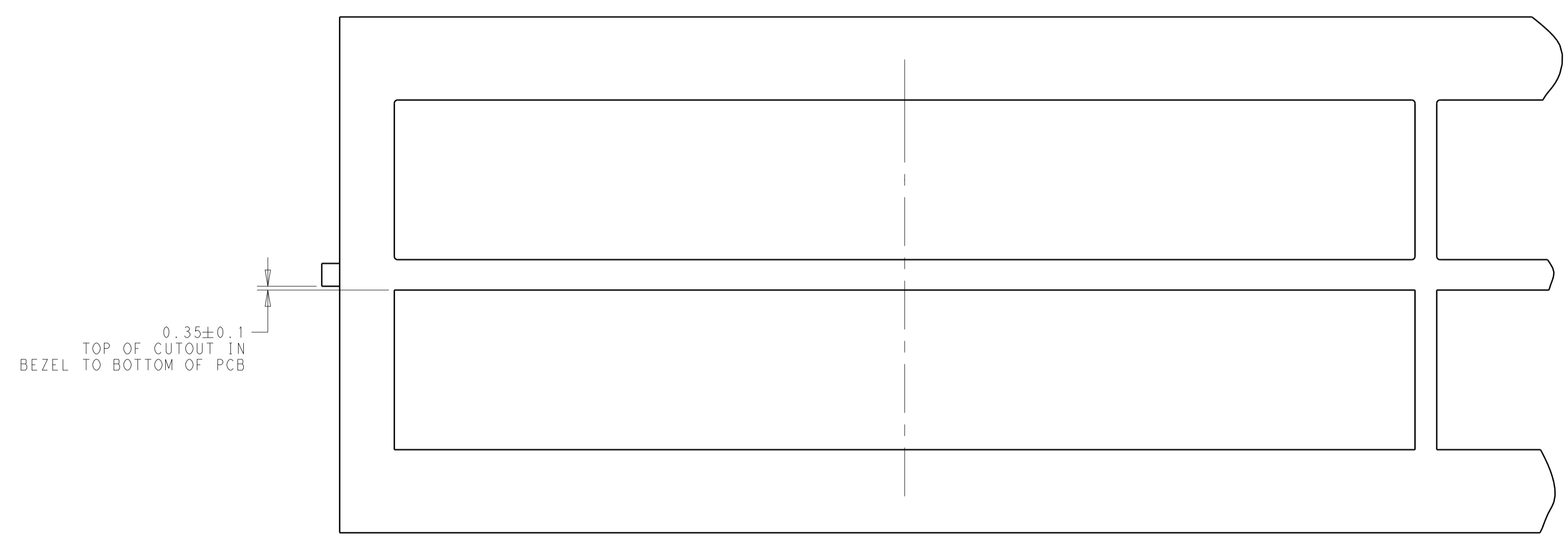

BELLY TO BELLY MOUNTING  
 SAME AS SINGLE SIDE  
 EXCEPT AS NOTED

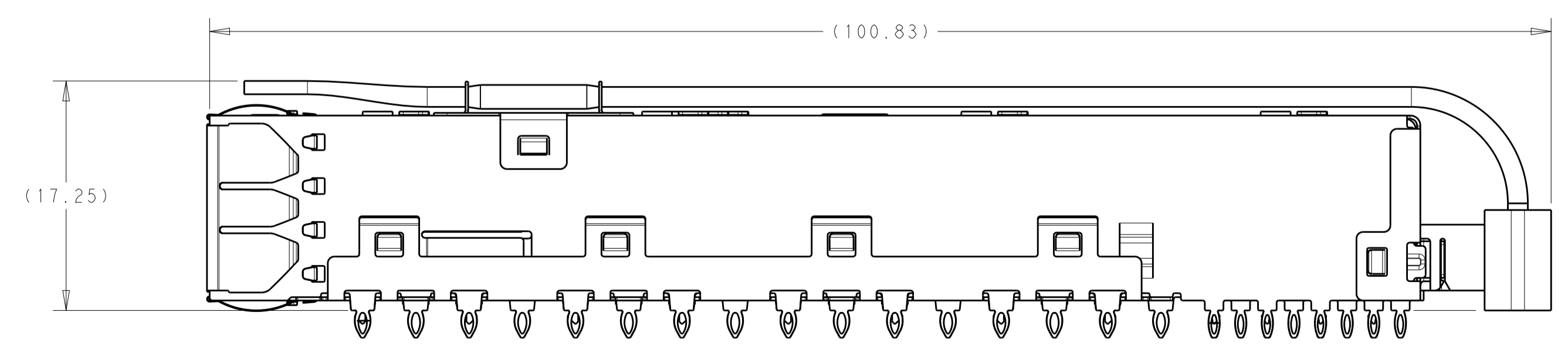

THIS DRAWING IS A CONTROLLED DOCUMENT.		DWN C. VALENTINE 18JUN2018	TE Connectivity
DIMENSIONS:		CHK D. HARMON 18JUN2018	
mm	TOLERANCES UNLESS OTHERWISE SPECIFIED:	APVD D. HARMON 18JUN2018	NAME CAGE ASSEMBLY, 1X4, OSFP
0 PLC ±	1 PLC ±0.25	PRODUCT SPEC	SIZE
2 PLC ±0.15	3 PLC ±0.10	108-60117	A1
4 PLC ±	ANGLES ±	APPLICATION SPEC	CAGE CODE DRAWING NO
MATERIAL	FINISH	114-130009	RESTRICTED TO
		WEIGHT	C=2338495
		CUSTOMER DRAWING	SCALE 3:1 SHEET 4 OF 8 REV E1

REVISIONS				
P.	LTN	DESCRIPTION	DATE	APVD
-	-	SEE SHEET 1	-	-

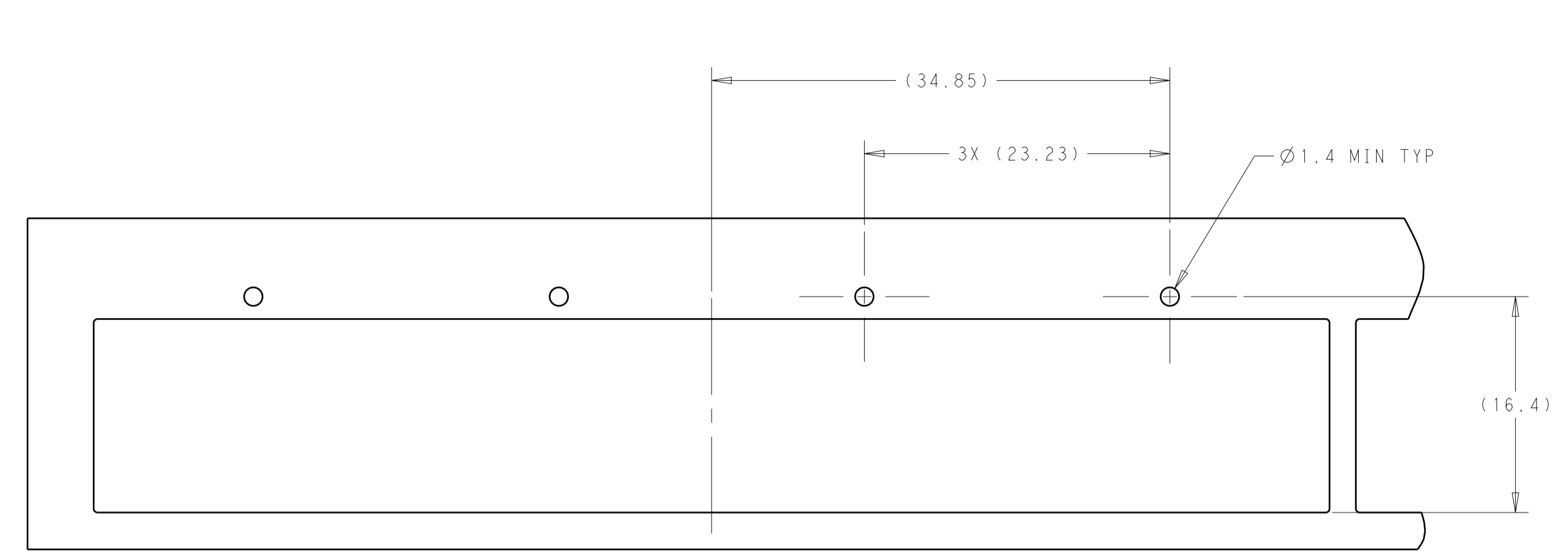

BEZEL LAYOUT FOR SINGLE LIGHT PIPE  
SINGLE SIDE

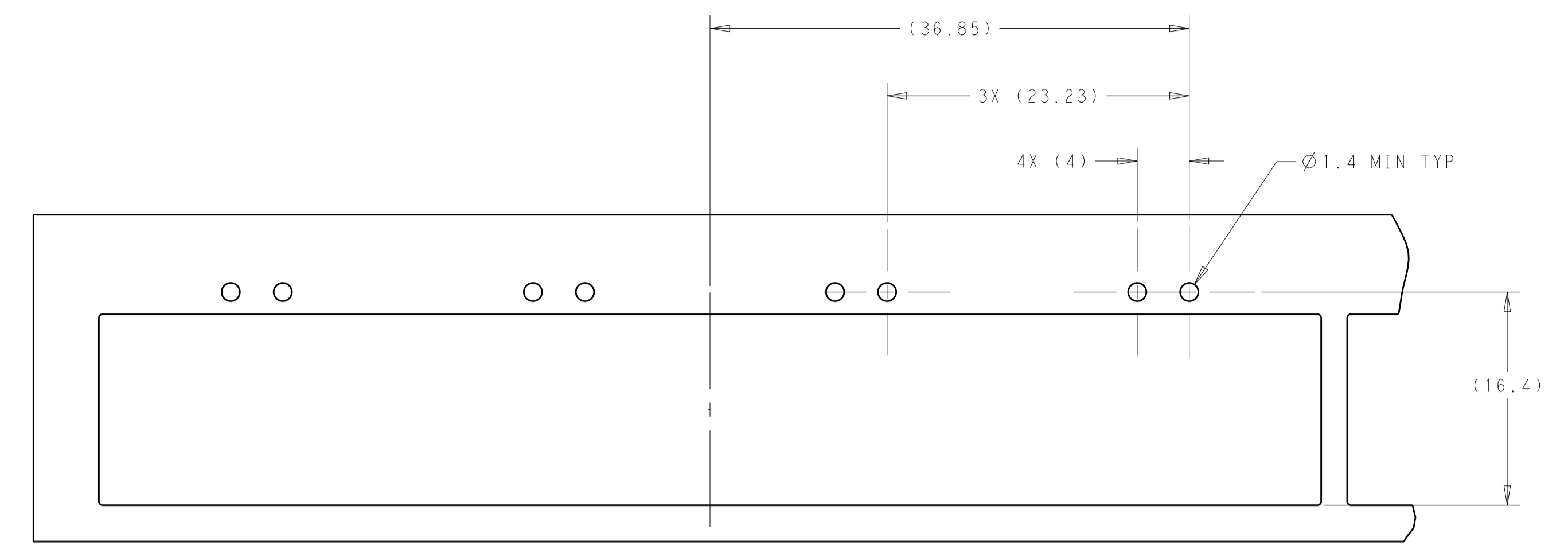

BEZEL LAYOUT FOR DOUBLE LIGHT PIPE  
SINGLE SIDE

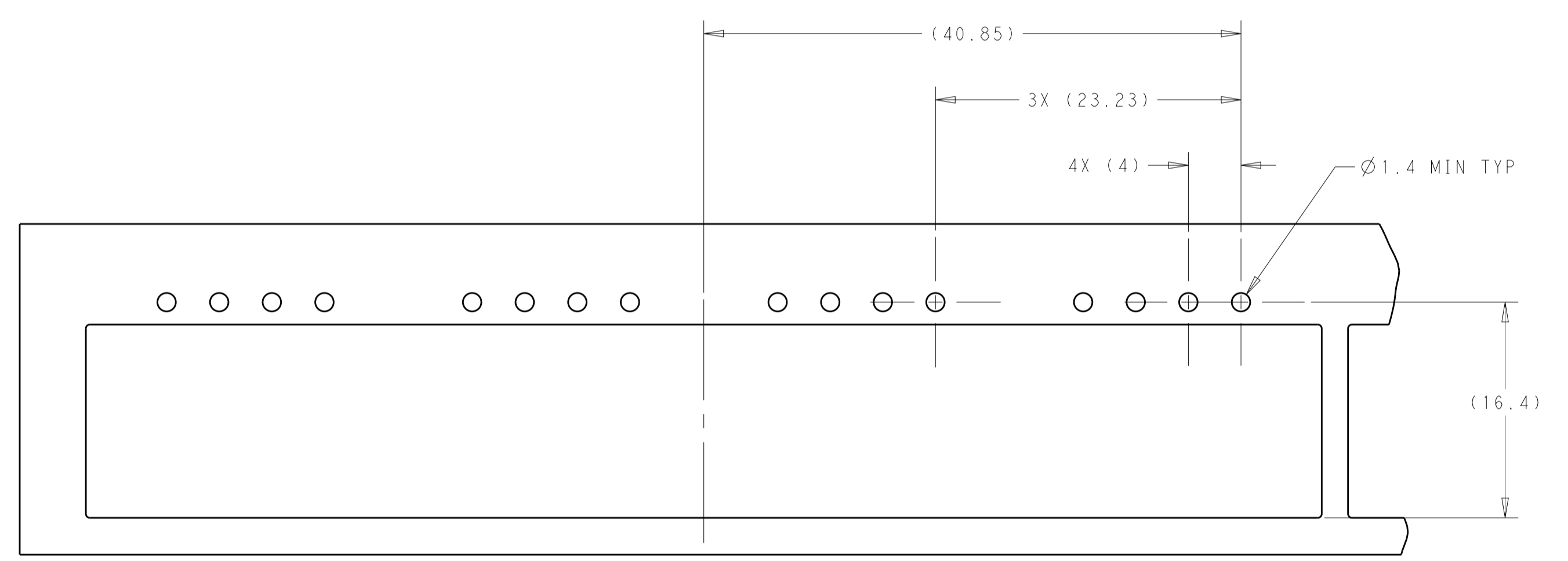

BEZEL LAYOUT FOR QUAD LIGHT PIPE  
SINGLE SIDE

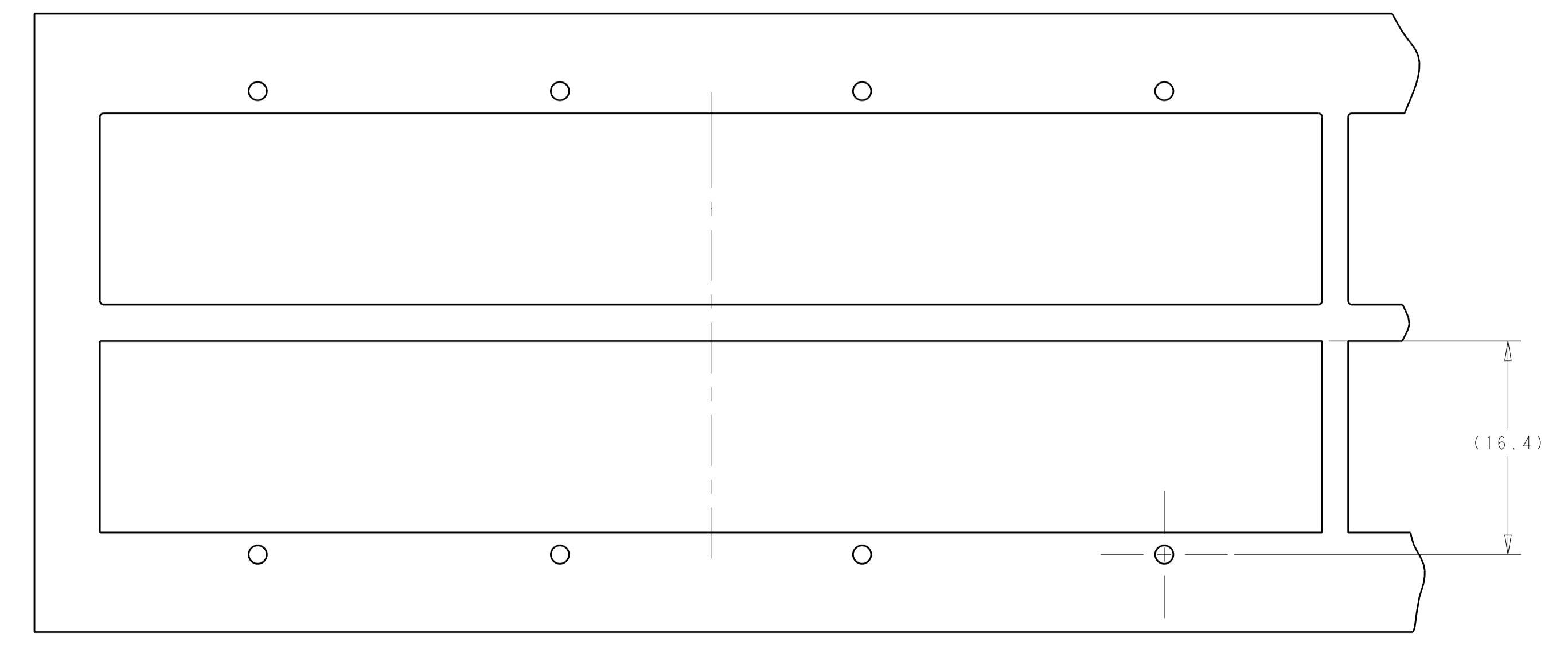

BEZEL LAYOUT FOR LIGHT PIPES  
BELLY TO BELLY  
SIMILAR TO SINGLE SIDE  
EXCEPT WHERE NOTED

THIS DRAWING IS A CONTROLLED DOCUMENT.		DWN C. VALENTINE 18JUN2018	 TE Connectivity
DIMENSIONS: mm		CHK D. HARMON 18JUN2018	
TOLERANCES UNLESS OTHERWISE SPECIFIED:		APVD D. HARMON 18JUN2018	NAME CAGE ASSEMBLY, 1X4, OSFP
0 PLC ±0.25	1 PLC ±0.15	PRODUCT SPEC	108-60117
2 PLC ±0.10	3 PLC ±0.10	APPLICATION SPEC	114-130009
4 PLC ±0.10	ANGLES ±0.10	FINISH	114-130009
MATERIAL	FINISH	WEIGHT	114-130009
CUSTOMER DRAWING		SCALE	3:1
SHEET		5	OF 8
REV		E	1

REVISIONS				
P.	LTN	DESCRIPTION	DATE	APVD
-	-	SEE SHEET 1	-	-

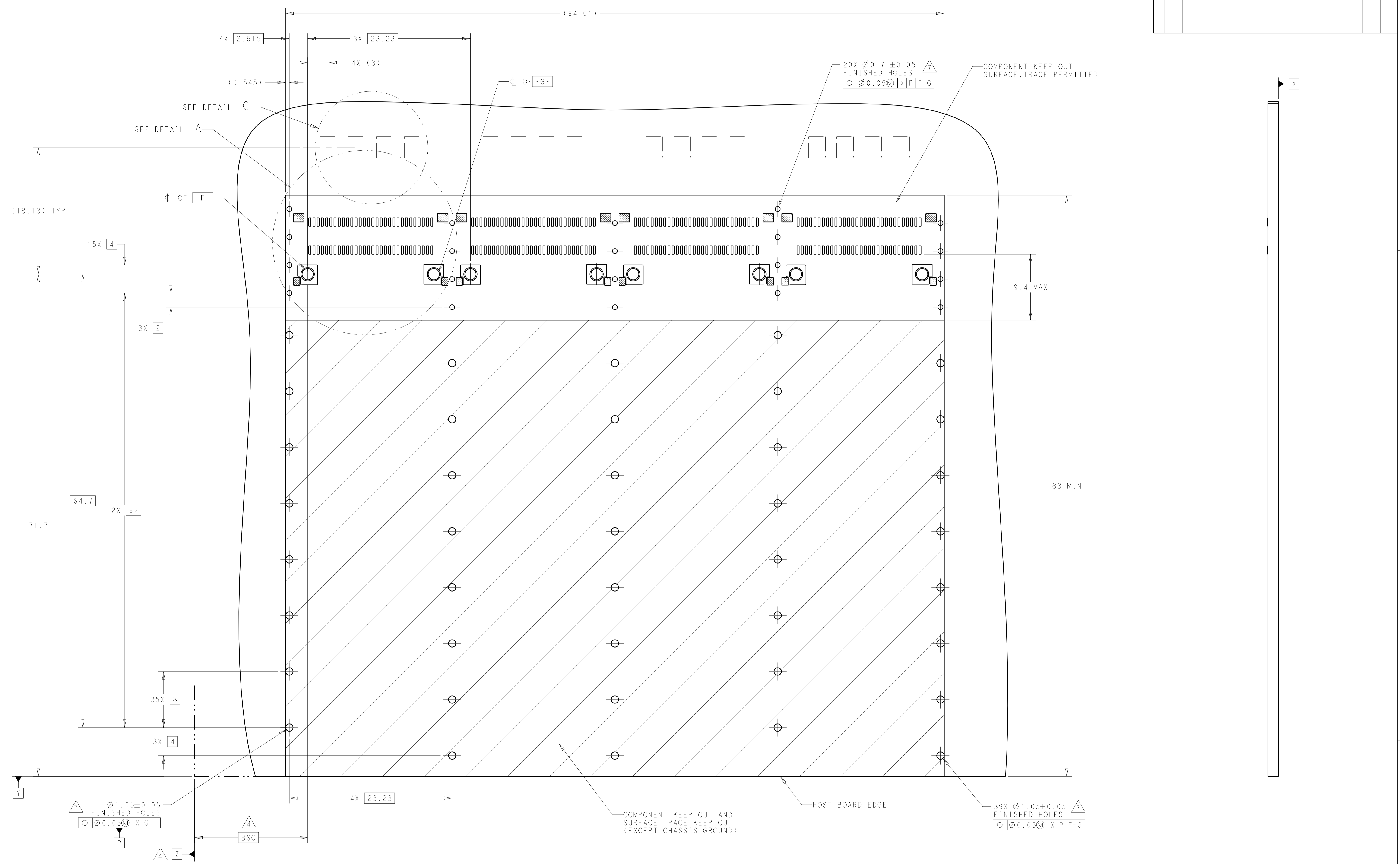

RECOMMENDED PCB LAYOUT  
 SINGLE SIDED APPLICATION  
 SCALE 4:1

THIS DRAWING IS A CONTROLLED DOCUMENT.		DWN C. VALENTINE 18JUN2018	18JUN2018	TE Connectivity																			
DIMENSIONS:		CHK D. HARMON 18JUN2018	18JUN2018																				
mm	TOLERANCES UNLESS OTHERWISE SPECIFIED:	APVD D. HARMON 18JUN2018	18JUN2018	NAME CAGE ASSEMBLY, 1X4, OSFP																			
<table border="1"> <tr><td>0 PLC</td><td>±</td></tr> <tr><td>1 PLC</td><td>±0.25</td></tr> <tr><td>2 PLC</td><td>±0.15</td></tr> <tr><td>3 PLC</td><td>±0.10</td></tr> <tr><td>4 PLC</td><td>±</td></tr> <tr><td>ANGLES</td><td>±</td></tr> </table>	0 PLC	±	1 PLC	±0.25	2 PLC	±0.15	3 PLC	±0.10	4 PLC	±	ANGLES	±	<table border="1"> <tr><td>PRODUCT SPEC</td><td>108-60117</td></tr> <tr><td>APPLICATION SPEC</td><td>114-130009</td></tr> <tr><td>WEIGHT</td><td></td></tr> </table>	PRODUCT SPEC	108-60117	APPLICATION SPEC	114-130009	WEIGHT		SIZE A1	CAGE CODE -	DRAWING NO. C=2338495	RESTRICTED TO -
0 PLC	±																						
1 PLC	±0.25																						
2 PLC	±0.15																						
3 PLC	±0.10																						
4 PLC	±																						
ANGLES	±																						
PRODUCT SPEC	108-60117																						
APPLICATION SPEC	114-130009																						
WEIGHT																							
MATERIAL	FINISH	CUSTOMER DRAWING		SCALE 3:1	SHEET 6 OF 8	REV E1																	

REVISIONS				
P	LTN	DESCRIPTION	DATE	APVD
-	-	SEE SHEET 1	-	-

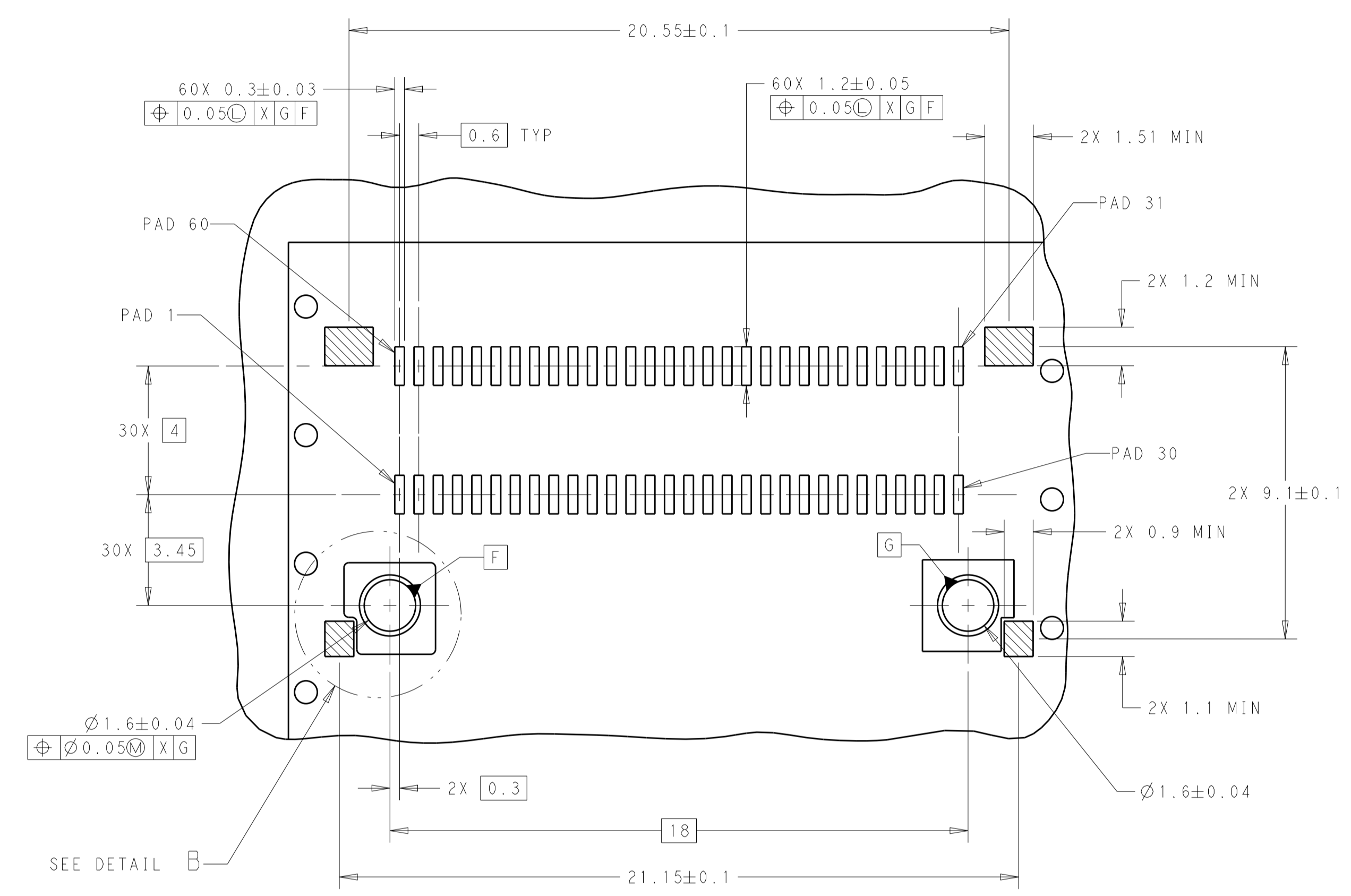

4X INDIVIDUALLY  
 DETAIL A  
 SCALE 8:1

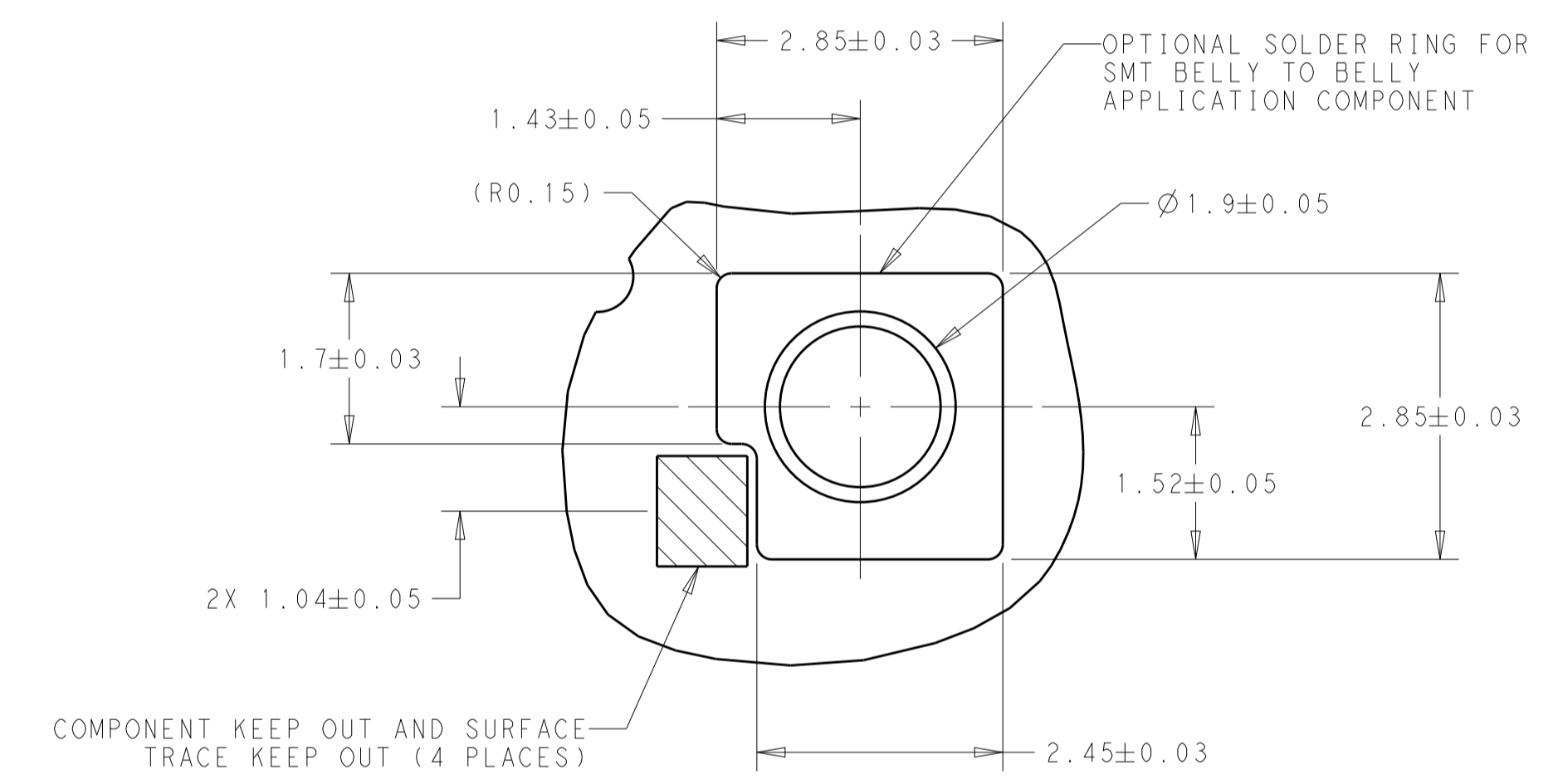

DETAIL B  
 SCALE 16:1

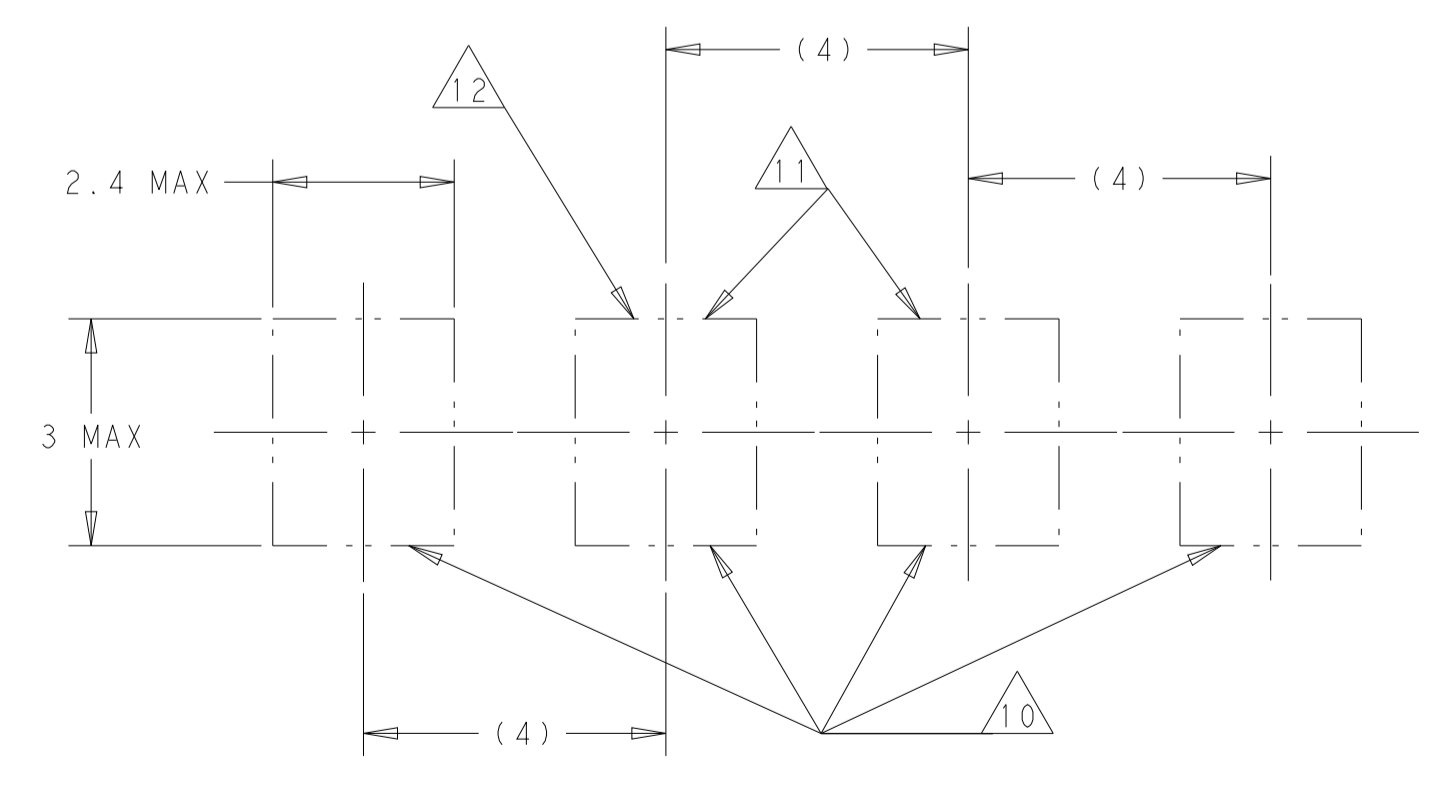

DETAIL C  
 SCALE 10:1

THIS DRAWING IS A CONTROLLED DOCUMENT.		OWN C. VALENTINE 18JUN2018	TE Connectivity
DIMENSIONS: mm		CHK D. HARMON 18JUN2018	
TOLERANCES UNLESS OTHERWISE SPECIFIED:		APVD D. HARMON 18JUN2018	NAME CAGE ASSEMBLY, 1X4, OSFP
0 PLC ±	1 PLC ±0.25	PRODUCT SPEC	-
2 PLC ±0.15	3 PLC ±0.10	108-60117	-
4 PLC ±	ANGLES ±	APPLICATION SPEC	-
MATERIAL	FINISH	114-130009	SIZE A1
CUSTOMER DRAWING		WEIGHT	CAGE CODE 2338495
SCALE 3:1		SHEET 7 OF 8	REV E1

REVISIONS				
P.	LTN	DESCRIPTION	DATE	APVD
-	-	SEE SHEET 1	-	-

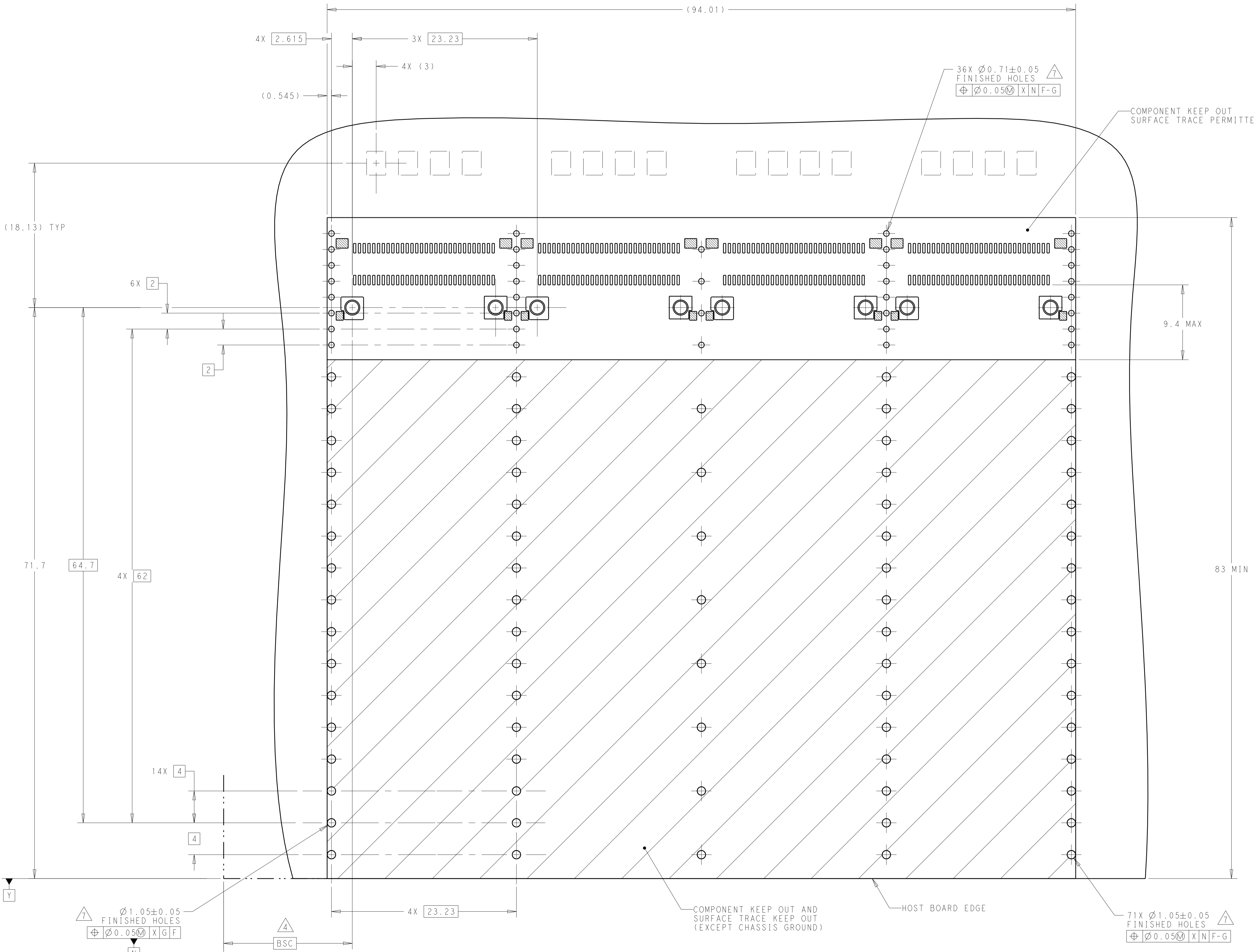

RECOMMENDED PCB LAYOUT  
BELLY TO BELLY APPLICATION  
SCALE 4:1

THIS DRAWING IS A CONTROLLED DOCUMENT.		DWN C. VALENTINE 18JUN2018	 TE Connectivity
DIMENSIONS: mm		CHK D. HARMON 18JUN2018	
TOLERANCES UNLESS OTHERWISE SPECIFIED: 0 PLC ±. 1 PLC ±0.25 2 PLC ±0.15 3 PLC ±0.10 4 PLC ±. ANGLES ±. FINISH ±.		APVD D. HARMON 18JUN2018	NAME CAGE ASSEMBLY, 1X4, OSFP
MATERIAL		PRODUCT SPEC 108-60117	SIZE A1
		APPLICATION SPEC 114-130009	CAGE CODE C=2338495
		WEIGHT	RESTRICTED TO
		CUSTOMER DRAWING	SCALE 3:1 SHEET 8 OF 8 REV E1