



# 8-BIT MAGNITUDE COMPARATORS

The SN54/74LS682, 684, 688 are 8-bit magnitude comparators. These device types are designed to perform comparisons between two eight-bit binary or BCD words. All device types provide  $\overline{P=Q}$  outputs and the LS682 and LS684 have  $P>Q$  outputs also.

The LS682, LS684 and LS688 are totem pole devices. The LS682 has a 20 kΩ pullup resistor on the Q inputs for analog or switch data.

## CONNECTION DIAGRAMS (TOP VIEW)

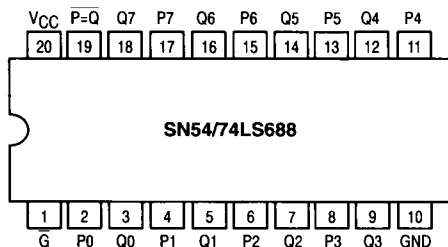
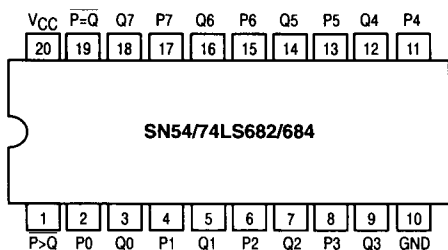

TYPE	$\overline{P=Q}$	$\overline{P>Q}$	OUTPUT ENABLE	OUTPUT CONFIGURATION	PULLUP
LS682	yes	yes	no	totem-pole	yes
LS684	yes	yes	no	totem-pole	no
LS688	yes	no	yes	totem-pole	no

**SN54/74LS682  
SN54/74LS684  
SN54/74LS688**

**8-BIT MAGNITUDE COMPARATORS**

**LOW POWER SCHOTTKY**

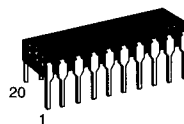

**J SUFFIX  
CERAMIC  
CASE 732-03**

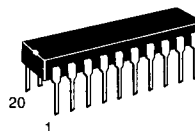

**N SUFFIX  
PLASTIC  
CASE 738-03**

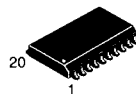

**DW SUFFIX  
SOIC  
CASE 751D-03**

## ORDERING INFORMATION

SN54LSXXXJ Ceramic  
SN74LSXXXN Plastic  
SN74LSXXXDW SOIC

## FUNCTION TABLE

INPUTS			OUTPUTS	
DATA	ENABLES		$\overline{P=Q}$	$\overline{P>Q}$
P, Q	$\overline{G}, \overline{GT}$	$\overline{G2}$		
P = Q	L	L	L	H
P > Q	L	L	H	L
P < Q	L	L	H	H
X	H	H	H	H

H = HIGH Level, L = LOW Level, X = Irrelevant

# SN54/74LS682 • SN54/74LS684 • SN54/74LS688

## GUARANTEED OPERATING RANGES

Symbol	Parameter		Min	Typ	Max	Unit
V <sub>CC</sub>	Supply Voltage	54 74	4.5 4.75	5.0 5.0	5.5 5.25	V
T <sub>A</sub>	Operating Ambient Temperature Range	54 74	-55 0	25 25	125 70	°C
I <sub>OH</sub>	Output Current — High	54, 74			-0.4	mA
I <sub>OL</sub>	Output Current — Low	54 74			12 24	mA

## DC CHARACTERISTICS OVER OPERATING TEMPERATURE RANGE (unless otherwise specified)

Symbol	Parameter	Limits			Unit	Test Conditions	
		Min	Typ	Max			
V <sub>IH</sub>	Input HIGH Voltage	2.0			V	Guaranteed Input HIGH Voltage for All Inputs	
V <sub>IL</sub>	Input LOW Voltage	54		0.7	V	Guaranteed Input LOW Voltage for All Inputs	
		74		0.8			
V <sub>IK</sub>	Input Clamp Diode Voltage		-0.65	-1.5	V	V <sub>CC</sub> = MIN, I <sub>IN</sub> = -18 mA	
V <sub>OH</sub>	Output HIGH Voltage	54	2.5	3.5	V	V <sub>CC</sub> = MIN, I <sub>OH</sub> = MAX, V <sub>IN</sub> = V <sub>IH</sub> or V <sub>IL</sub> per Truth Table	
		74	2.7	3.5	V		
V <sub>OL</sub>	Output LOW Voltage	54, 74		0.25	0.4	I <sub>OL</sub> = 12 mA	V <sub>CC</sub> = V <sub>CC</sub> MIN, V <sub>IN</sub> = V <sub>IL</sub> or V <sub>IH</sub> per Truth Table
		74		0.35	0.5	I <sub>OL</sub> = 24 mA	
I <sub>IH</sub>	Input HIGH Current				20	μA	V <sub>CC</sub> = MAX, V <sub>IN</sub> = 2.7 V
		LS628-Q Inputs			0.1	mA	V <sub>CC</sub> = MAX, V <sub>IN</sub> = 5.5 V
		Others			0.1	mA	V <sub>CC</sub> = MAX, V <sub>IN</sub> = 7.0 V
I <sub>IL</sub>	Input LOW Current	LS682-Q Inputs			-0.4	mA	V <sub>CC</sub> = MAX, V <sub>IN</sub> = 0.4 V
		Others			-0.2	mA	
I <sub>OS</sub>	Short Circuit Current (Note 1)		-30		-130	mA	V <sub>CC</sub> = MAX
I <sub>CC</sub>	Power Supply Current	LS682			70	mA	V <sub>CC</sub> = MAX
		LS684			65	mA	
		LS688			65	mA	

Note 1: Not more than one output should be shorted at a time, nor for more than 1 second.

# SN54/74LS682 • SN54/74LS684 • SN54/74LS688

## LOGIC DIAGRAMS

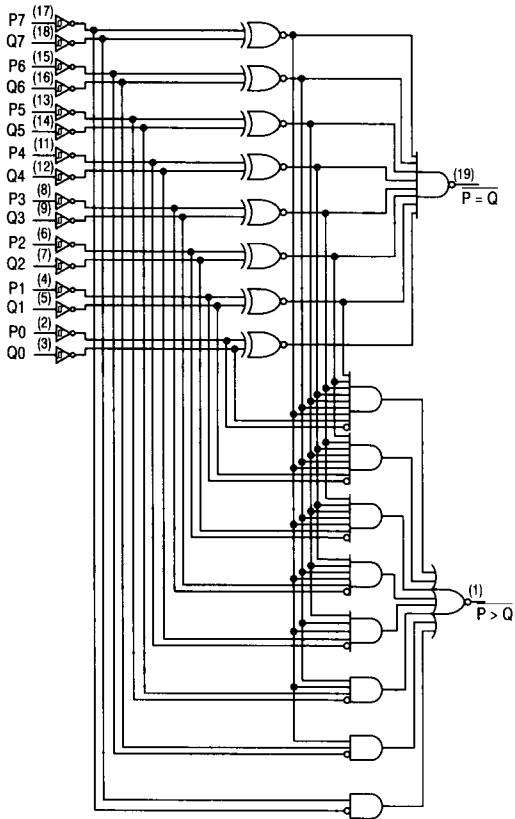

SN54/74LS682 thru LS684

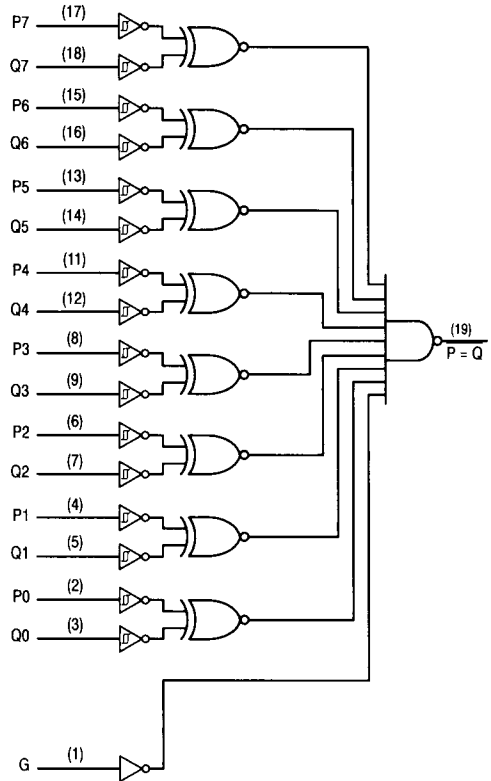

SN54/74LS688

5

# SN54/74LS682•SN54/74LS684•SN54/74LS688

## AC CHARACTERISTICS (T<sub>A</sub> = 25°C)

### SN54/74LS682

Symbol	Parameter	Limits			Unit	Test Conditions
		Min	Typ	Max		
t <sub>PLH</sub> t <sub>PHL</sub>	Propagation Delay, P to $\overline{P} = \overline{Q}$		13 15	25 25	ns	V <sub>CC</sub> = 5.0 V C <sub>L</sub> = 45 pF R <sub>L</sub> = 667 Ω
t <sub>PLH</sub> t <sub>PHL</sub>	Propagation Delay, Q to $\overline{P} = \overline{Q}$		14 15	25 25	ns	
t <sub>PLH</sub> t <sub>PHL</sub>	Propagation Delay, P to $\overline{P} > \overline{Q}$		20 15	30 30	ns	
t <sub>PLH</sub> t <sub>PHL</sub>	Propagation Delay, Q to $\overline{P} > \overline{Q}$		21 19	30 30	ns	

### SN54/74LS684

Symbol	Parameter	Limits			Unit	Test Conditions
		Min	Typ	Max		
t <sub>PLH</sub> t <sub>PHL</sub>	Propagation Delay, P to $\overline{P} = \overline{Q}$		15 17	25 25	ns	V <sub>CC</sub> = 5.0 V C <sub>L</sub> = 45 pF R <sub>L</sub> = 667 Ω
t <sub>PLH</sub> t <sub>PHL</sub>	Propagation Delay, Q to $\overline{P} = \overline{Q}$		16 15	25 25	ns	
t <sub>PLH</sub> t <sub>PHL</sub>	Propagation Delay, P to $\overline{P} > \overline{Q}$		22 17	30 30	ns	
t <sub>PLH</sub> t <sub>PHL</sub>	Propagation Delay, Q to $\overline{P} > \overline{Q}$		24 20	30 30	ns	

### SN54/74LS688

Symbol	Parameter	Limits			Unit	Test Conditions
		Min	Typ	Max		
t <sub>PLH</sub> t <sub>PHL</sub>	Propagation Delay, P to $\overline{P} = \overline{Q}$		12 17	18 23	ns	V <sub>CC</sub> = 5.0 V C <sub>L</sub> = 45 pF R <sub>L</sub> = 667 Ω
t <sub>PLH</sub> t <sub>PHL</sub>	Propagation Delay, Q to $\overline{P} = \overline{Q}$		12 17	18 23	ns	
t <sub>PLH</sub> t <sub>PHL</sub>	Propagation Delay, $\overline{G}, \overline{G1}$ to $\overline{P} = \overline{Q}$		12 13	18 20	ns	