

© 1969 BY AMP INCORPORATED. ALL RIGHTS RESERVED. AMP PRODUCTS COVERED BY PATENTS AND/OR PATENTS PENDING.

REVISIONS				
ZONE	LTR	DESCRIPTION	DATE	APPROVED
	A	REDRAWN & REVISED 2078	9-14-69	m.s. J.H.
	B	LOC. SWASAB, DIST 12 WAS 39 9347	1-7-72	JP
	C	OBSOLETE - 2, BRIGHT TIN .0001 WAS TIN, EA 970	2-1-79	DJA
	D	BRIGHT TIN-LEAD WAS BRIGHT TIN, EA 1818	6-18-81	DS
	E	REV PER DF-2051	10-3-89	mlc
	F	REV PER DF-2412, REACT-3	T.W.	mlc
	G	REV PER OH14-0139-05	1-06	PY RG

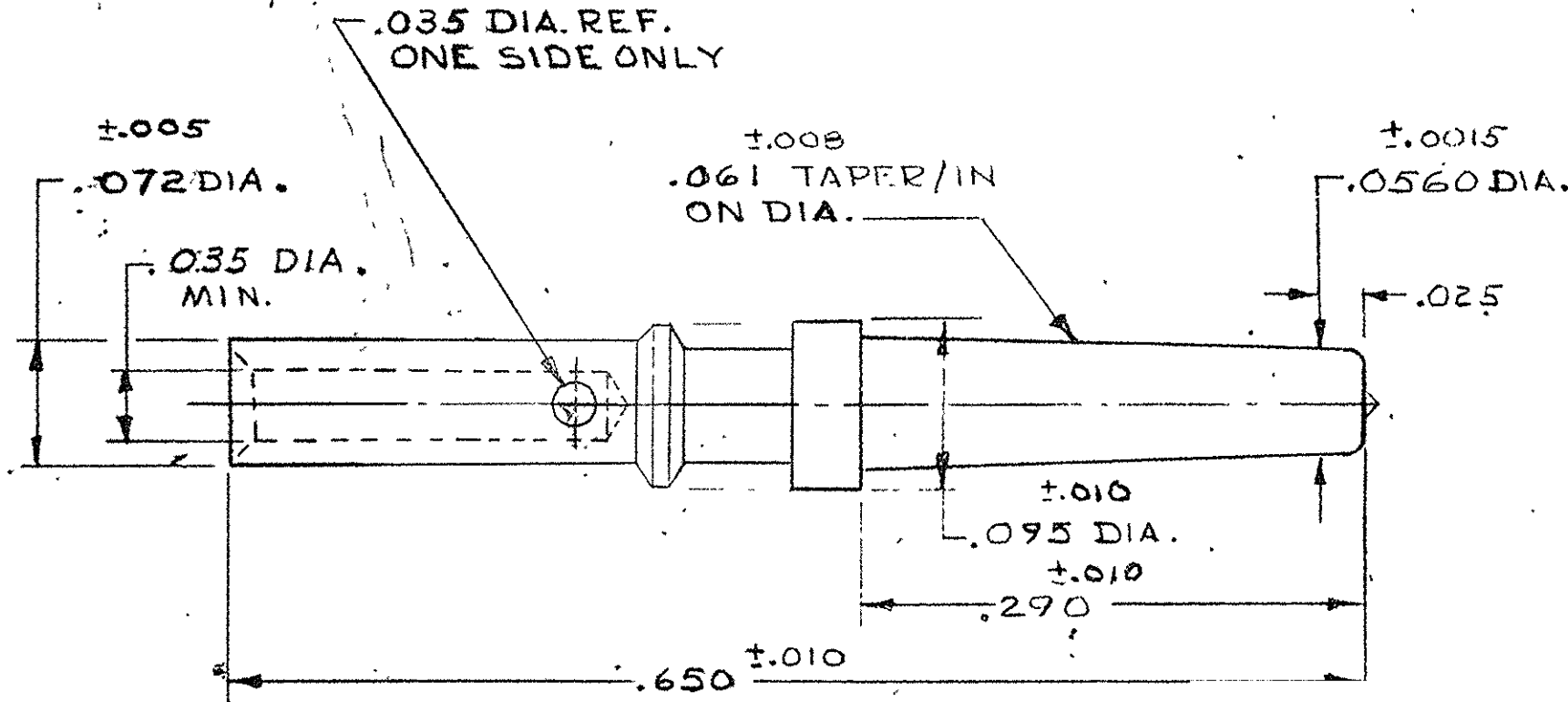

- 1 BRIGHT TIN-LEAD ± .0001 THICK
- 2 SILVER ± .0002 THICK
- 3 GOLD ± .000030 OVER .000050 NICKEL.
- 4 MATTE TIN - .0001 THICK

PART NO.	FINISH.	WIRE SIZE
66074-1	1	#24 - #22
66074-2	2	#24 - #22
66074-3	3	#24 - #22
5-66074-1	4	#24 - #22

UNLESS OTHERWISE SPECIFIED DIMENSIONS ARE IN INCHES TOLERANCES ON: DECIMALS ± .015 ANGLES ±	CONTRACT NO.	AMP AMP INCORPORATED HARRISBURG, PENNSYLVANIA		
	DRY CHK APPD REL			
	MATERIAL	NAME		
	BRASS	PIN, TAPER, "53" SERIES, UNINSULATED		
	DSGN APPD	SIZE	CODE IDENT NO.	NUMBER
	OTHER APPD	B	00779	66074
		SCALE 10-1		SHEET