

THIS DRAWING IS UNPUBLISHED.

RELEASED FOR PUBLICATION

20

© COPYRIGHT 20 BY -

ALL RIGHTS RESERVED.

REVISIONS

P	LTR	DESCRIPTION	DATE	DWN	APVD
	A	IN PRODUCTION	-	R.M	-
	A1	REVISED FOR ET00-0402-97	15-10-1997	M.P	-
	C	REVISED FOR ET00-0088-03	9-06-03	M.P.	-
	C1	REDRAWN TO CREO	17APR2017	GH	JP

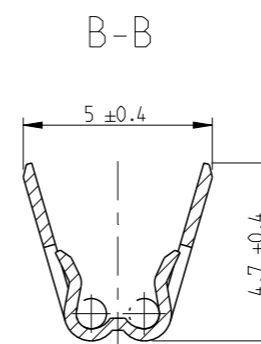
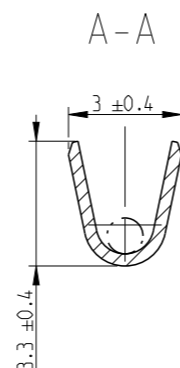
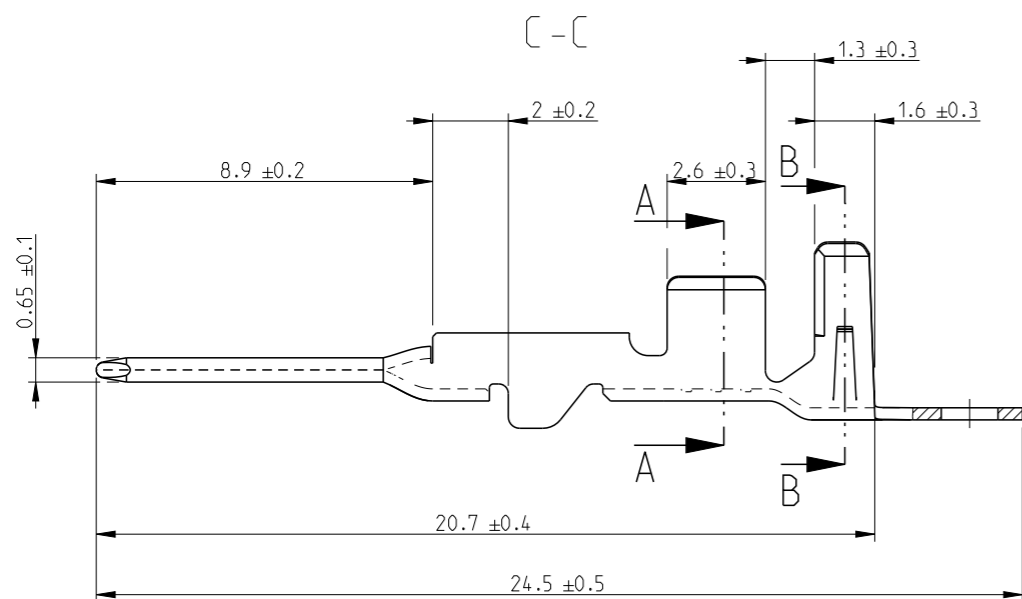
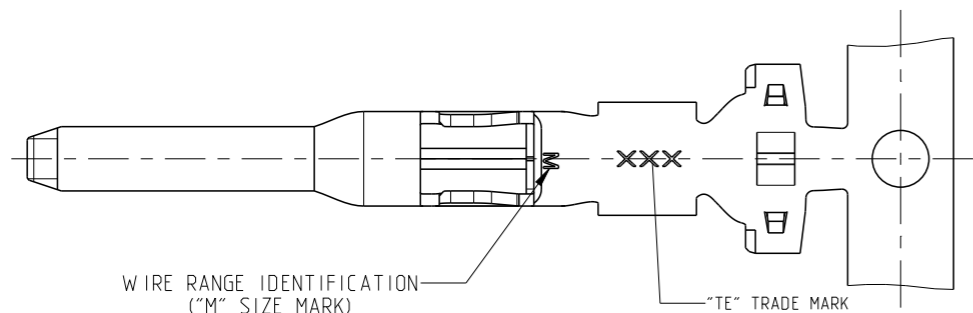

1. DELIVERY STATE: ITEM IS SUPPLIED REELED ON CARTON REEL WITH STRIP PITCH = 11.9±0.2mm
 STATO DI FORNITURA: AVVOLTI SU BOBINA CON PASSO TRA TERMINALI DI = 11.9±0.2mm

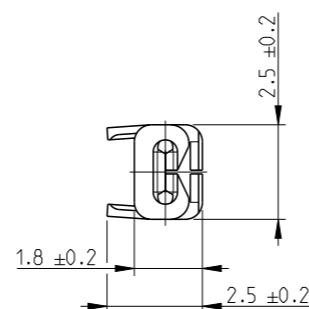
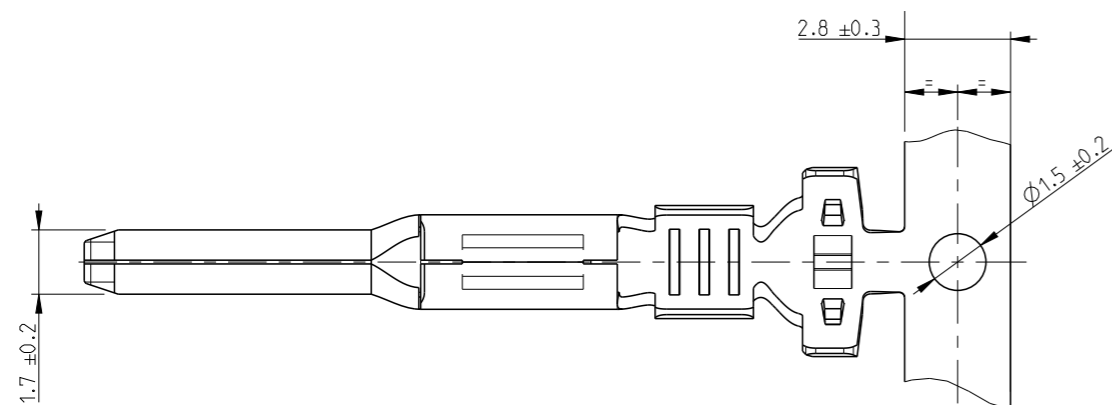

CUSTOMER DRAWING FOR INFORMATION ONLY
 DISEGNO PER CLIENTE SOLO PER RIFERIMENTO

PRE-TIN (PRE-STAGNATO)	BRASS (OTTONE)	282378-1
FINISH/COLOUR (FINITURE/COLORE)	MATERIAL (MATERIALE)	PART NUMBER

THIS DRAWING IS A CONTROLLED DOCUMENT.

DWN R. MARTINI 3JUN1993

CHK C. TARTARI 3JUN1993

APVD -

PRODUCT SPEC 108-20159

APPLICATION SPEC 114-20057

WEIGHT -

CUSTOMER DRAWING



NAME .070 SERIES MULTILOCK TAB CONTACT

SIZE A3 CAGE CODE - DRAWING NO C=282378 RESTRICTED TO -

SCALE 5:1 SHEET 1 OF 1 REV C1

DIRECTION OFF TOP OF REEL
 SENSO DI USCITA DALLA BOBINA

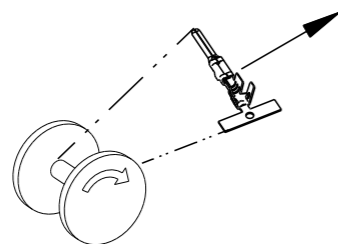

INS. DIA. RANGE (DIAM. ISOLANTE)	WIRE RANGE (RANGO FILO)
Ø1.9 - 2.6mm	0.75 - 1.5mm ²

DIMENSIONS: mm	TOLERANCES UNLESS OTHERWISE SPECIFIED:
	0 PLC ± 1 PLC ± 2 PLC ± 3 PLC ± 4 PLC ±
	±0.3
	±2°
MATERIAL	FINISH
-	-