

OD-RAM HOLE PATTERN
(CONNECTOR SIDE)

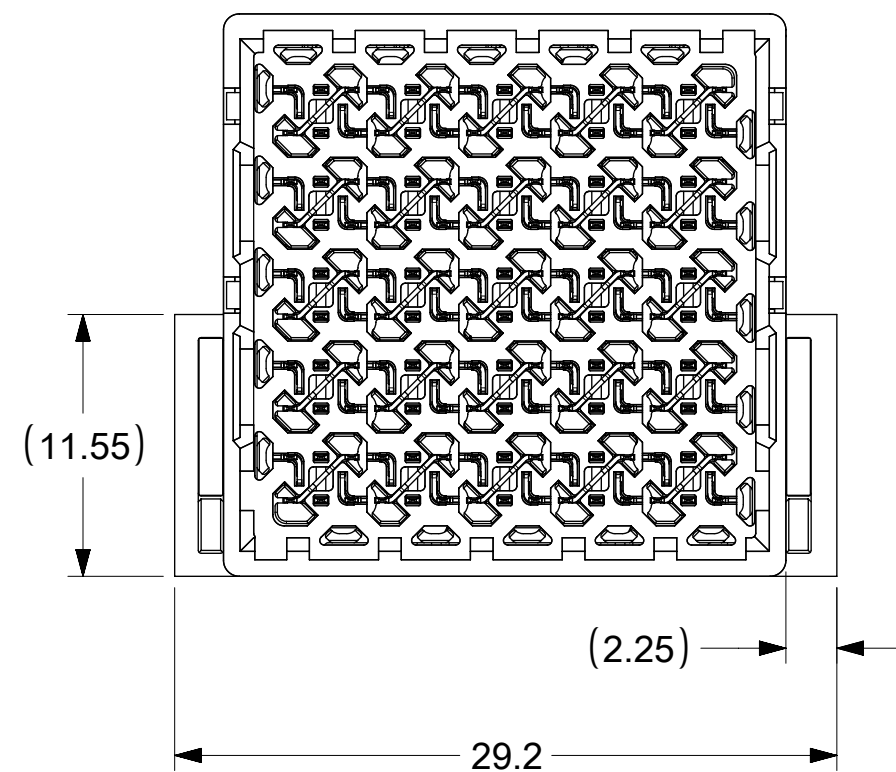

THIS DRAWING CONTAINS INFORMATION THAT IS PROPRIETARY TO MOLEX ELECTRONIC TECHNOLOGIES, LLC AND SHOULD NOT BE USED WITHOUT WRITTEN PERMISSION																	
DIMENSION UNITS		SCALE		CURRENT REV DESC: MIGRATED TO NX													
MM		NTS		<p>IMPACT ORTHOGONAL DIRECT 5 PAIR RAM 90 & 270 ASSY UNGUIDED SALES DRAWING</p> <p>PRODUCT CUSTOMER DRAWING</p> <table border="1"> <tr> <td>DOCUMENT NUMBER</td> <td>DOC TYPE</td> <td>DOC PART</td> <td>REVISION</td> </tr> <tr> <td>SD-171575-0001</td> <td>PSD</td> <td>001</td> <td>B3</td> </tr> </table>						DOCUMENT NUMBER	DOC TYPE	DOC PART	REVISION	SD-171575-0001	PSD	001	B3
DOCUMENT NUMBER	DOC TYPE	DOC PART	REVISION														
SD-171575-0001	PSD	001	B3														
GENERAL TOLERANCES (UNLESS SPECIFIED)																	
ANGULAR TOL ± 0.5°																	
4 PLACES ±																	
3 PLACES ±																	
2 PLACES ± 0.13																	
1 PLACE ± 0.25																	
0 PLACES ±																	
DRAFT WHERE APPLICABLE MUST REMAIN WITHIN DIMENSIONS				THIRD ANGLE PROJECTION		DRAWING		SERIES									
		C-SIZE		171575		MATERIAL NUMBER		CUSTOMER									
						SEE CHART		GENERAL MARKET									
						SHEET NUMBER		1 OF 4									

DOCUMENT STATUS	P1	RELEASE DATE	2022/05/13	03:05:12
-----------------	----	--------------	------------	----------

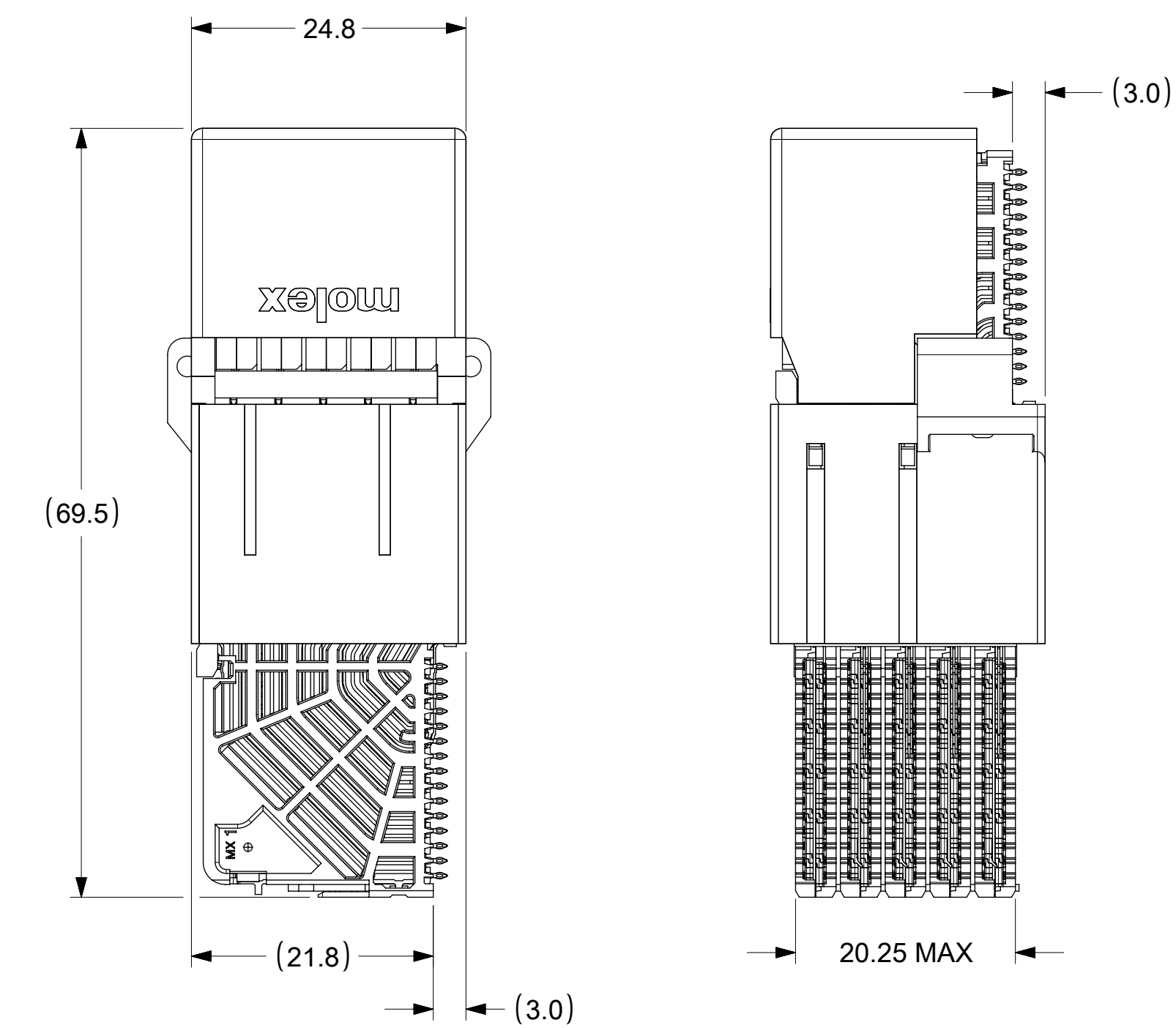

MATED DIMENSIONS
(POSITION 90° SHOWN)

- NOTES:
- MATERIALS: HOUSING - LIQUID CRYSTAL POLYMER (LCP)
GLASS-FILLED, UL94V-0
TERMINALS - HIGH PERFORMANCE COPPER ALLOY
 - FINISH: 30μ MIN GOLD IN CONTACT AREA.
SELECTIVE TIN ON PCB TAILS.
NICKEL OVERALL.
 - REFER TO MOLEX PRODUCT SPECIFICATION PS-76060-999 FOR PERFORMANCE SPECIFICATIONS AND ADDITIONAL PCB INFORMATION.
 - THIS PART CONFORMS TO CLASS B REQUIREMENTS OF COSMETIC SPEC PS-45499-002.
 - PACKAGE PER: PK-70873-8022.
 - SEE SHEET 3 AND 4 FOR ORTHOGONAL PIN MAPPING.
 - REFER TO MOLEX SALES DRAWING SD-76990-001 FOR THE MATING RECEPTACLES.
 - REFER TO MOLEX ROUTING GUIDE AS-76850-990 FOR ADDITIONAL PCB LAYOUT AND ROUTING RECOMMENDATIONS.
 - CONNECTORS ARE SUPPLIED WITH TWO 2-32 SCREWS P/N 73726-0000. (9.50mm±0.38 THREADABLE SCREW LENGTH). THE MAXIMUM BOARD THICKNESS IS 4.4mm.
 - THESE DIMENSIONS REPRESENT THE AREA NEEDED TO ACCOMODATE CONNECTOR INSERTION AND REPAIR ON THE PC BOARD. THIS IS REFERRED TO AS THE "CONNECTOR KEEP OUT ZONE" AND DOES NOT REPRESENT THE ACTUAL PERIMETER OF THE CONNECTOR.
 - MARKING: LOCATED APPROXIMATELY AS SHOWN, ON THE BOTTOM OR TOP OF HOUSING. PART NUMBER AND DATE CODE.

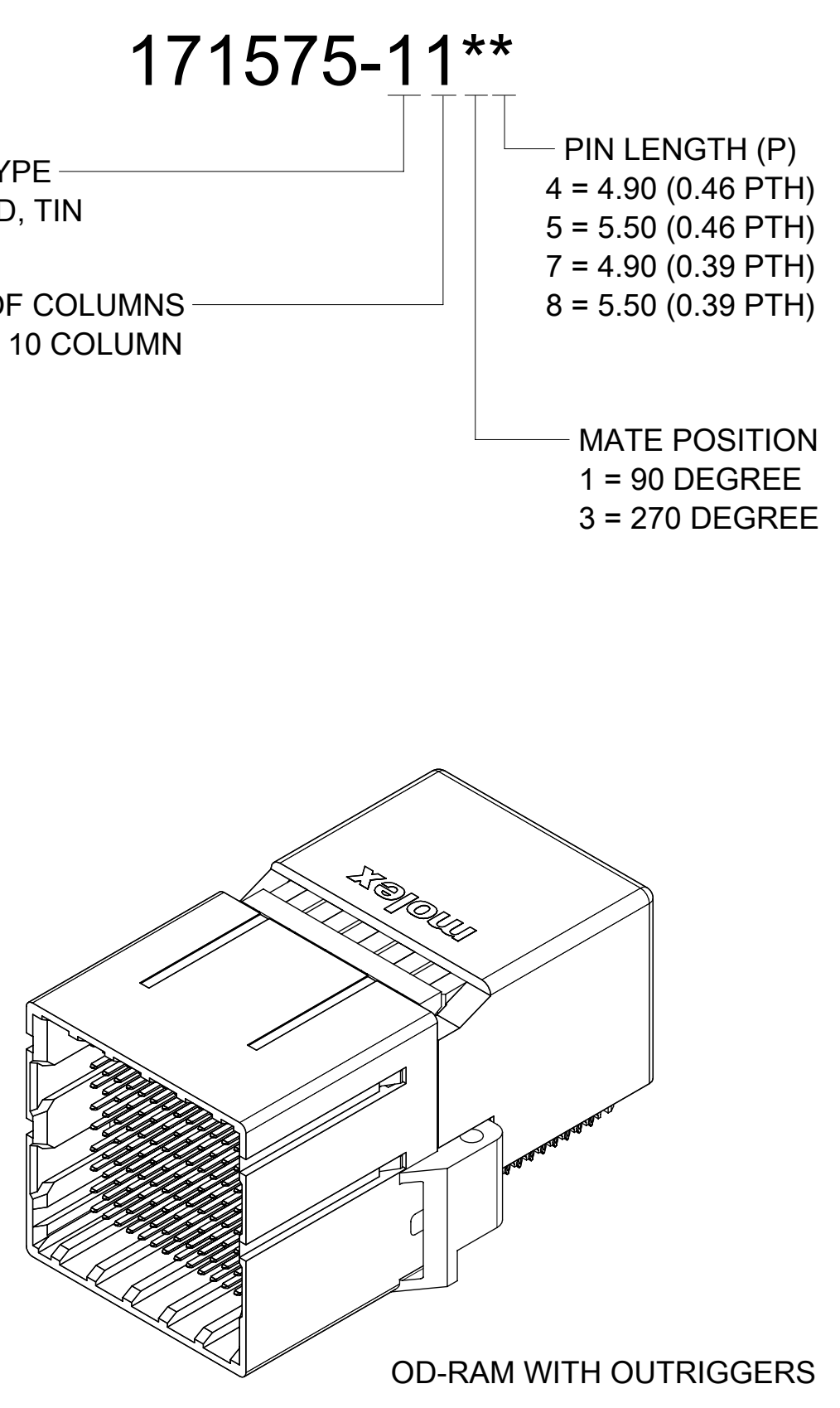

THIS DRAWING CONTAINS INFORMATION THAT IS PROPRIETARY TO MOLEX ELECTRONIC TECHNOLOGIES, LLC AND SHOULD NOT BE USED WITHOUT WRITTEN PERMISSION									
DIMENSION UNITS		SCALE		CURRENT REV DESC: MIGRATED TO NX				molex	
MM	NTS								
GENERAL TOLERANCES (UNLESS SPECIFIED)				EC NO: 705090				IMPACT ORTHOGONAL DIRECT 5 PAIR RAM 90 & 270 ASSY UNGUIDED SALES DRAWING	
ANGULAR TOL ± 0.5°				DRWN: TMARRI 2018/09/18					
4 PLACES ±				CHK'D: VINODM3 2022/02/17					
3 PLACES ±				APPR: LZENG 2022/05/13				PRODUCT CUSTOMER DRAWING	
2 PLACES ± 0.13				INITIAL REVISION:				DOCUMENT NUMBER	
1 PLACE ± 0.25				DRWN: JMENDOZA 2012/04/13				SD-171575-0001	
0 PLACES ±				APPR: TELO 2013/12/26				DOC TYPE DOC PART REVISION	
DRAFT WHERE APPLICABLE MUST REMAIN WITHIN DIMENSIONS		THIRD ANGLE PROJECTION		DRAWING		SERIES		MATERIAL NUMBER	
		C-SIZE		171575		SEE CHART		CUSTOMER	
						GENERAL MARKET		SHEET NUMBER	
								2 OF 4	

DOCUMENT STATUS	P1	RELEASE DATE	2022/05/13	03:05:12
-----------------	----	--------------	------------	----------

ORTHO POSITION 90°

OD-RAM PIN A1 MAPS
TO RAF PIN Q10

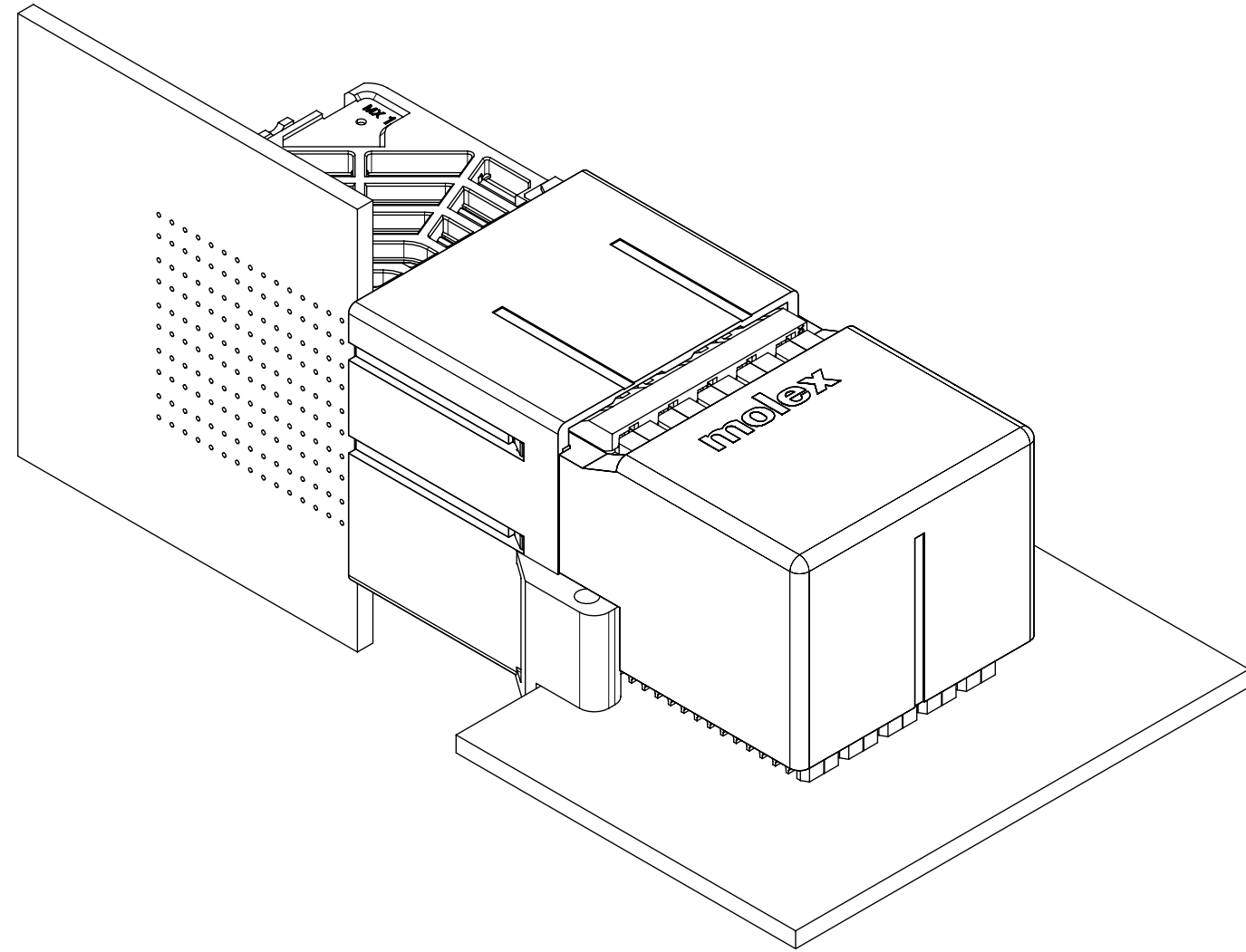

ORTHO PIN MAPPING

OPTION 90 (NEARSIDE - FAR SIDE)

A1-Q10	A2-P10	A3-M10	A4-L10	A5-J10	A6-H10	A7-F10	A8-E10	A9-C10	A10-B10
B1-Q9	B2-N10	B3-M9	B4-K10	B5-J9	B6-G10	B7-F9	B8-D10	B9-C9	B10-A10
C1-P9	C2-N9	C3-L9	C4-K9	C5-H9	C6-G9	C7-E9	C8-D9	C9-B9	C10-A9
D1-Q8	D2-P8	D3-M8	D4-L8	D5-J8	D6-H8	D7-F8	D8-E8	D9-C8	D10-B8
E1-Q7	E2-N8	E3-M7	E4-K8	E5-J7	E6-G8	E7-F7	E8-D8	E9-C7	E10-A8
F1-P7	F2-N7	F3-L7	F4-K7	F5-H7	F6-G7	F7-E7	F8-D7	F9-B7	F10-A7
G1-Q6	G2-P6	G3-M6	G4-L6	G5-J6	G6-H6	G7-F6	G8-E6	G9-C6	G10-B6
H1-Q5	H2-N6	H3-M5	H4-K6	H5-J5	H6-G6	H7-F5	H8-D6	H9-C5	H10-A6
J1-P5	J2-N5	J3-L5	J4-K5	J5-H5	J6-G5	J7-E5	J8-D5	J9-B5	J10-A5
K1-Q4	K2-P4	K3-M4	K4-L4	K5-J4	K6-H4	K7-F4	K8-E4	K9-C4	K10-B4
L1-Q3	L2-N4	L3-M3	L4-K4	L5-J3	L6-G4	L7-F3	L8-D4	L9-C3	L10-A4
M1-P3	M2-N3	M3-L3	M4-K3	M5-H3	M6-G3	M7-E3	M8-D3	M9-B3	M10-A3
N1-Q2	N2-P2	N3-M2	N4-L2	N5-J2	N6-H2	N7-F2	N8-E2	N9-C2	N10-B2
P1-Q1	P2-N2	P3-M1	P4-K2	P5-J1	P6-G2	P7-F1	P8-D2	P9-C1	P10-A2
Q1-P1	Q2-N1	Q3-L1	Q4-K1	Q5-H1	Q6-G1	Q7-E1	Q8-D1	Q9-B1	Q10-A1

NOTE: PINOUTS SHOWN IN BALLOONS ARE GROUNDS.
GROUND PATHS ARE NOT DISCRETE CIRCUITS.

MATERIAL NUMBER	# OF COLUMNS	# OF DIFF PAIR	MATE POSITION	DIM P	PTH Ø
171575-1114	10	50	90	4.90	0.46±0.05
171575-1115	10	50	90	5.50	0.46±0.05
171575-1117	10	50	90	4.90	0.39±0.05
171575-1118	10	50	90	5.50	0.39±0.05

THIS DRAWING CONTAINS INFORMATION THAT IS PROPRIETARY TO MOLEX ELECTRONIC TECHNOLOGIES, LLC AND SHOULD NOT BE USED WITHOUT WRITTEN PERMISSION

DIMENSION UNITS	SCALE	CURRENT REV DESC: MIGRATED TO NX				
MM	NTS					
GENERAL TOLERANCES (UNLESS SPECIFIED)		EC NO: 705090		IMPACT ORTHOGONAL DIRECT 5 PAIR RAM 90 & 270 ASSY UNGUIDED SALES DRAWING		
ANGULAR TOL ± 0.5°		DRWN: TMARRI 2018/09/18				
4 PLACES ±		CHK'D: VINODM3 2022/02/17		PRODUCT CUSTOMER DRAWING		
3 PLACES ±		APPR: LZENG 2022/05/13				
2 PLACES ± 0.13		INITIAL REVISION:		DOCUMENT NUMBER SD-171575-0001		
1 PLACE ± 0.25		DRWN: JMENDOZA 2012/04/13				
0 PLACES ±		APPR: TELO 2013/12/26		DOC TYPE DOC PART REVISION PSD 001 B3		
DRAFT WHERE APPLICABLE MUST REMAIN WITHIN DIMENSIONS		THIRD ANGLE PROJECTION				
		DRAWING		MATERIAL NUMBER CUSTOMER SHEET NUMBER SEE CHART GENERAL MARKET 3 OF 4		
		SERIES C-SIZE 171575				

ORTHO POSITION 270°
 OD-RAM PIN A1 MAPS
 TO RAF PIN A1

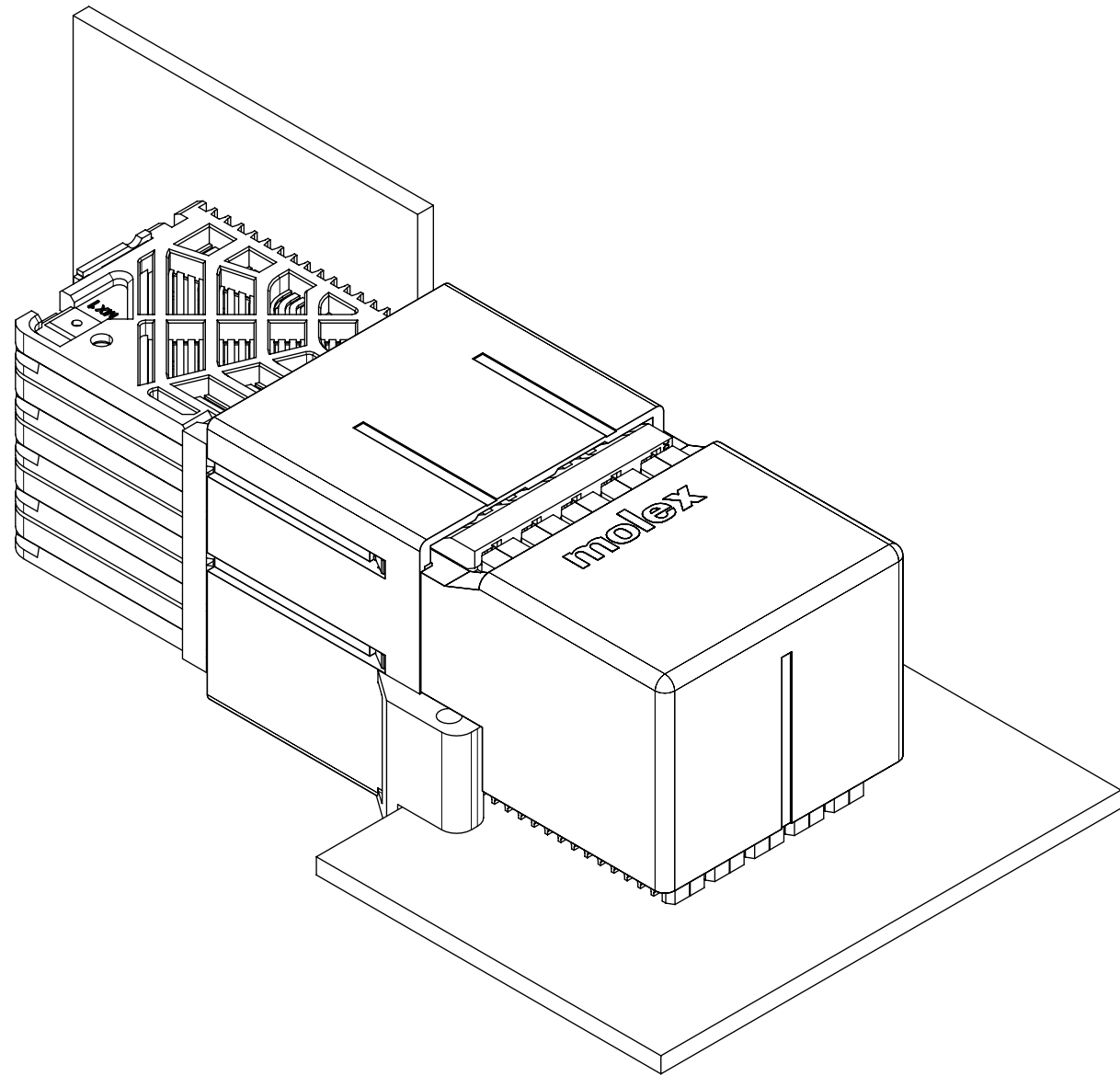

ORTHO PIN MAPPING

OPTION 270 (NEARSIDE - FAR SIDE)

A1-A1	A2-B1	A3-D1	A4-E1	A5-G1	A6-H1	A7-K1	A8-L1	A9-N1	A10-P1
B1-A2	B2-C1	B3-D2	B4-F1	B5-G2	B6-J1	B7-K2	B8-M1	B9-N2	B10-Q1
C1-B2	C2-C2	C3-E2	C4-F2	C5-H2	C6-J2	C7-L2	C8-M2	C9-P2	C10-Q2
D1-A3	D2-B3	D3-D3	D4-E3	D5-G3	D6-H3	D7-K3	D8-L3	D9-N3	D10-P3
E1-A4	E2-C3	E3-D4	E4-F3	E5-G4	E6-J3	E7-K4	E8-M3	E9-N4	E10-Q3
F1-B4	F2-C4	F3-E4	F4-F4	F5-H4	F6-J4	F7-L4	F8-M4	F9-P4	F10-Q4
G1-A5	G2-B5	G3-D5	G4-E5	G5-G5	G6-H5	G7-K5	G8-L5	G9-N5	G10-P5
H1-A6	H2-C5	H3-D6	H4-F5	H5-G6	H6-J5	H7-K6	H8-M5	H9-N6	H10-Q5
J1-B6	J2-C6	J3-E6	J4-F6	J5-H6	J6-J6	J7-L6	J8-M6	J9-P6	J10-Q6
K1-A7	K2-B7	K3-D7	K4-E7	K5-G7	K6-H7	K7-K7	K8-L7	K9-N7	K10-P7
L1-A8	L2-C7	L3-D8	L4-F7	L5-G8	L6-J7	L7-K8	L8-M7	L9-N8	L10-Q7
M1-B8	M2-C8	M3-E8	M4-F8	M5-H8	M6-J8	M7-L8	M8-M8	M9-P8	M10-Q8
N1-A9	N2-B9	N3-D9	N4-E9	N5-G9	N6-H9	N7-K9	N8-L9	N9-N9	N10-P9
P1-A10	P2-C9	P3-D10	P4-F9	P5-G10	P6-J9	P7-K10	P8-M9	P9-N10	P10-Q9
Q1-B10	Q2-C10	Q3-E10	Q4-F10	Q5-H10	Q6-J10	Q7-L10	Q8-M10	Q9-P10	Q10-Q10

NOTE: PINOUTS SHOWN IN BALLOONS ARE GROUNDS.
 GROUND PATHS ARE NOT DISCRETE CIRCUITS.

MATERIAL NUMBER	# OF COLUMNS	# OF DIFF PAIR	MATE POSITION	DIM P	PTH Ø
171575-1134	10	50	270	4.90	0.46±0.05
171575-1135	10	50	270	5.50	0.46±0.05
171575-1137	10	50	270	4.90	0.39±0.05
171575-1138	10	50	270	5.50	0.39±0.05

THIS DRAWING CONTAINS INFORMATION THAT IS PROPRIETARY TO MOLEX ELECTRONIC TECHNOLOGIES, LLC AND SHOULD NOT BE USED WITHOUT WRITTEN PERMISSION

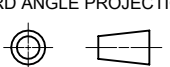
DIMENSION UNITS	SCALE	CURRENT REV DESC: MIGRATED TO NX		 IMPACT ORTHOGONAL DIRECT 5 PAIR RAM 90 & 270 ASSY UNGUIDED SALES DRAWING		
MM	NTS					
GENERAL TOLERANCES (UNLESS SPECIFIED)		EC NO: 705090		PRODUCT CUSTOMER DRAWING DOCUMENT NUMBER: SD-171575-0001 DOC TYPE: PSD DOC PART: 001 REVISION: B3 MATERIAL NUMBER: SEE CHART CUSTOMER: GENERAL MARKET SHEET NUMBER: 4 OF 4		
ANGULAR TOL	± 0.5°	DRWN: TMARRI 2018/09/18				
4 PLACES	±	CHK'D: VINODM3 2022/02/17				
3 PLACES	±	APPR: LZENG 2022/05/13				
2 PLACES	± 0.13	INITIAL REVISION:				
1 PLACE	± 0.25	DRWN: JMENDOZA 2012/04/13				
0 PLACES	±	APPR: TELO 2013/12/26				
DRAFT WHERE APPLICABLE MUST REMAIN WITHIN DIMENSIONS		THIRD ANGLE PROJECTION	DRAWING	SERIES		
			C-SIZE	171575		

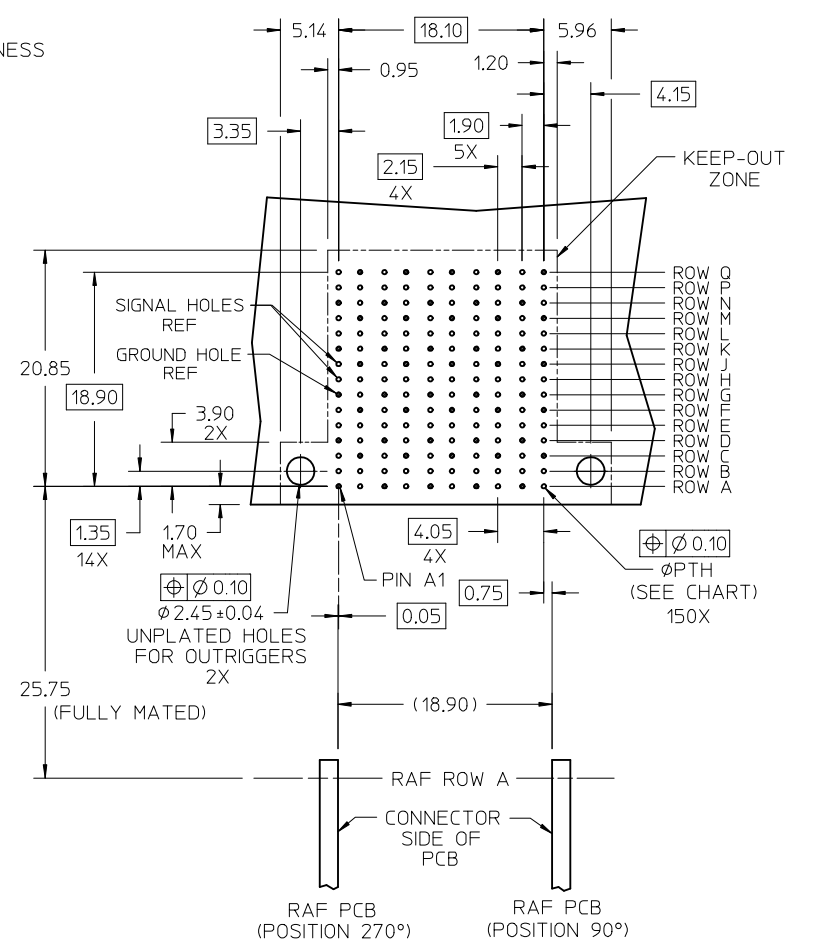
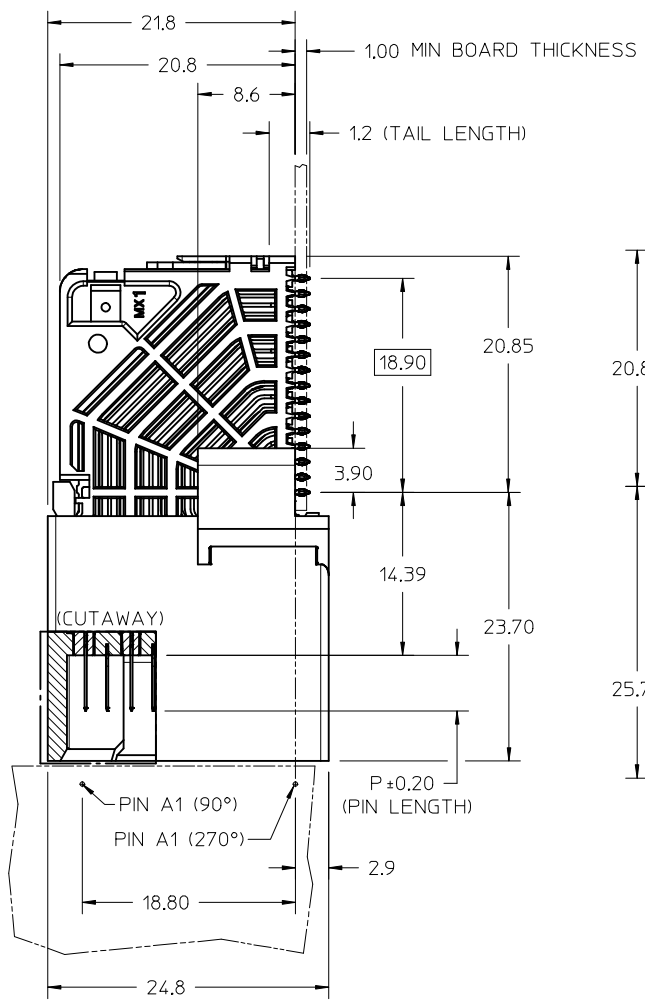
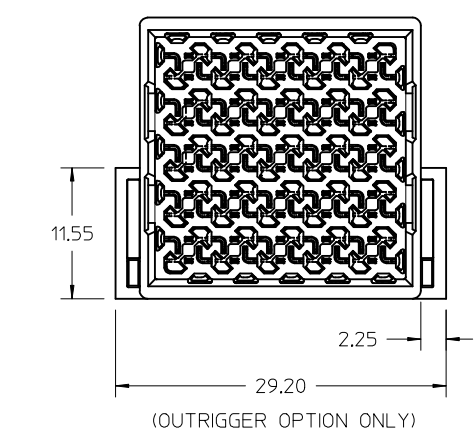
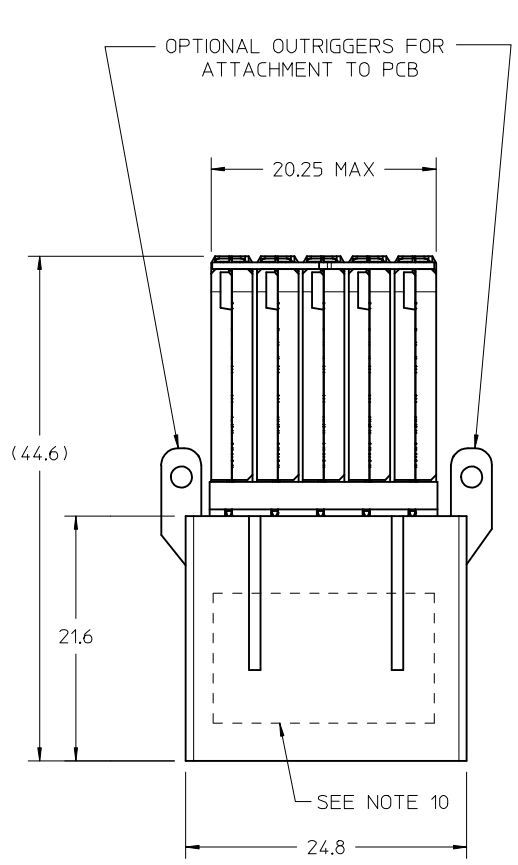

OD-RAM HOLE PATTERN
(CONNECTOR SIDE)

UPDATE TP. LASER MARK EC NO: UCP2016-3973 DRWNG:VARVARA 2015/08/24 CHKD:TELO 2016/02/22 APPR:TELO 2016/04/20	QUALITY SYMBOLS ▽=0 ▽=0	GENERAL TOLERANCES (UNLESS SPECIFIED)		DIMENSION STYLE MM ONLY	SCALE 3:1	DESIGN UNITS METRIC	THIRD ANGLE PROJECTION	
		4 PLACES ± --- ± ---	3 PLACES ± --- ± ---	DRAWN BY JMENDOZA	DATE 2011/04/11	TITLE IMPACT ORTHOGONAL DIRECT 5 PAIR RAM ASSEMBLY UNGUIDED SALES DRAWING		
		2 PLACES ± 0.13 ± ---	1 PLACE ± 0.25 ± ---	CHECKED BY JB INGHAM	DATE 2011/04/12	MOLEX INCORPORATED		
		ANGULAR ± 1/2°		APPROVED BY JB INGHAM	DATE 2011/04/21	MATERIAL NO. SEE CHART	DOCUMENT NO. SD-76725-001	SHEET NO. 1 OF 4
DRAFT WHERE APPLICABLE MUST REMAIN WITHIN DIMENSIONS		SIZE C		THIS DRAWING CONTAINS INFORMATION THAT IS PROPRIETARY TO MOLEX INCORPORATED AND SHOULD NOT BE USED WITHOUT WRITTEN PERMISSION				

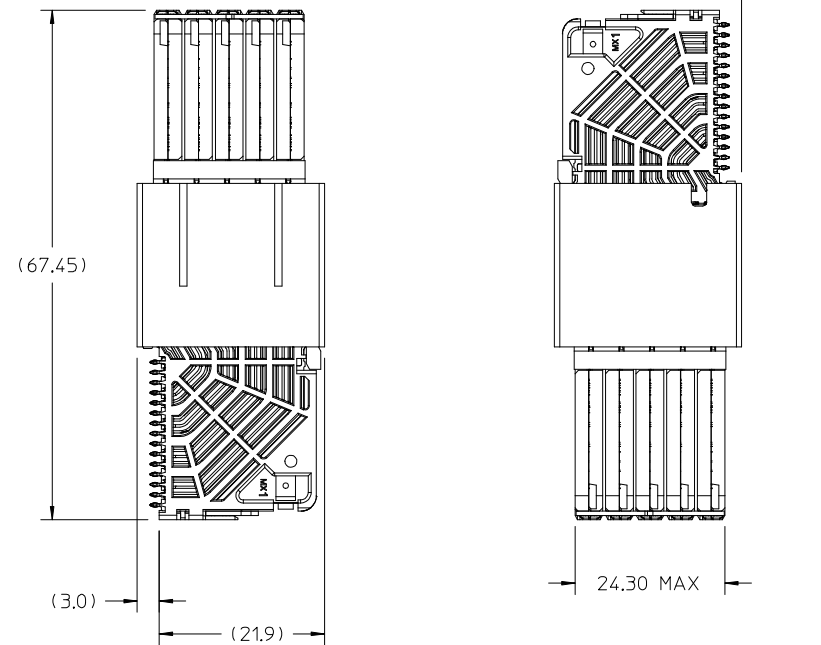

MATERIAL NUMBER	# OF COLUMNS	# OF DIFF PAIR	DIM P	PTH ϕ
76725-11*4	10	50	4.90	0.46±0.05
76725-11*5	10	50	5.50	0.46±0.05
76725-11*7	10	50	4.90	0.39±0.05
76725-11*8	10	50	5.50	0.39±0.05

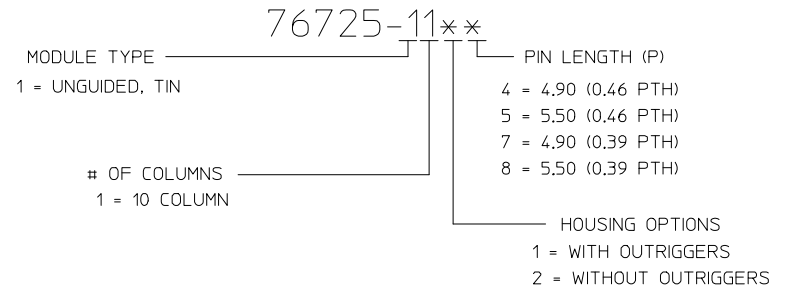

MATED DIMENSIONS
(POSITION 270° SHOWN, WITHOUT OUTRIGGERS)

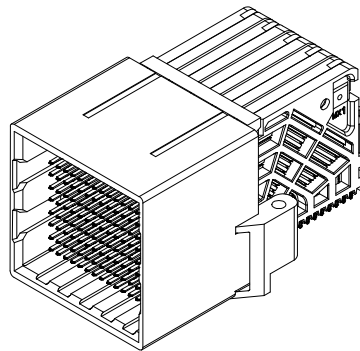

OD-RAM WITH OUTRIGGERS

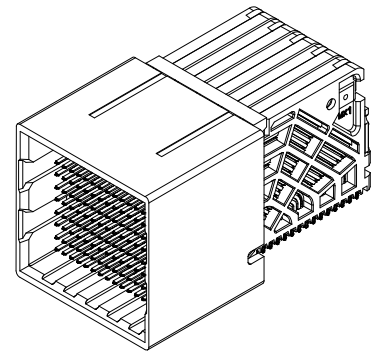

OD-RAM WITHOUT OUTRIGGERS

NOTES:

- MATERIALS: HOUSING - LIQUID CRYSTAL POLYMER (LCP)
GLASS-FILLED, UL94V-0
TERMINALS - HIGH PERFORMANCE COPPER ALLOY
- FINISH: 30 μ MIN GOLD IN CONTACT AREA.
SELECTIVE TIN ON PCB TAILS.
NICKEL OVERALL.
- REFER TO MOLEX PRODUCT SPECIFICATION PS-76060-999
FOR PERFORMANCE SPECIFICATIONS AND ADDITIONAL PCB INFORMATION.
- THIS PART CONFORMS TO CLASS B REQUIREMENTS OF
COSMETIC SPEC PS-45499-002.
- PACKAGE PER: PK-70873-8010.
- SEE SHEET 3 AND 4 FOR ORTHOGONAL PIN MAPPING.
- REFER TO MOLEX SALES DRAWING SD-76990-001 FOR THE MATING RECEPTACLES.
- REFER TO MOLEX ROUTING GUIDE AS-76850-990 FOR ADDITIONAL PCB LAYOUT
AND ROUTING RECOMMENDATIONS.
- CONNECTORS WITH OUTRIGGERS ARE SUPPLIED WITH TWO 2-32 THREAD
FORMING SCREWS.
- MARKING: LOCATED APPROXIMATELY AS SHOWN, ON BOTTOM OR TOP OF THE
HOUSING. PART NUMBER AND DATE CODE.

SEE SHEET 1 EC NO: UCP2016-3973 DRAWN BY: DRWINDYARVARA CHECKED BY: CHKD:TELO APPR:TELO REV: A2	DESCRIPTION 2015/08/24 2016/02/22 2016/04/20	QUALITY SYMBOLS =0 =0	GENERAL TOLERANCES (UNLESS SPECIFIED)		DIMENSION STYLE MM ONLY	SCALE 2:1	DESIGN UNITS METRIC	THIRD ANGLE PROJECTION
			mm	INCH	DRAWN BY JMENDOZA	DATE 2011/04/11	TITLE IMPACT ORTHOGONAL DIRECT 5 PAIR RAM ASSEMBLY UNGUIDED SALES DRAWING	
			4 PLACES ± --- ± ---		CHECKED BY JB INGHAM	DATE 2011/04/12	MOLEX INCORPORATED	
			3 PLACES ± --- ± ---		APPROVED BY JB INGHAM	DATE 2011/04/21	DOCUMENT NO. SD-76725-001	
			2 PLACES ± 0.13 ± ---		SEE CHART		SHEET NO. 2 OF 4	
			1 PLACE ± 0.25 ± ---		THIS DRAWING CONTAINS INFORMATION THAT IS PROPRIETARY TO MOLEX INCORPORATED AND SHOULD NOT BE USED WITHOUT WRITTEN PERMISSION			
			ANGULAR ±1/2°					
			DRAFT WHERE APPLICABLE MUST REMAIN WITHIN DIMENSIONS					

ORTHO POSITION 270°
 OD-RAM PIN A1 MAPS
 TO RAF PIN A1

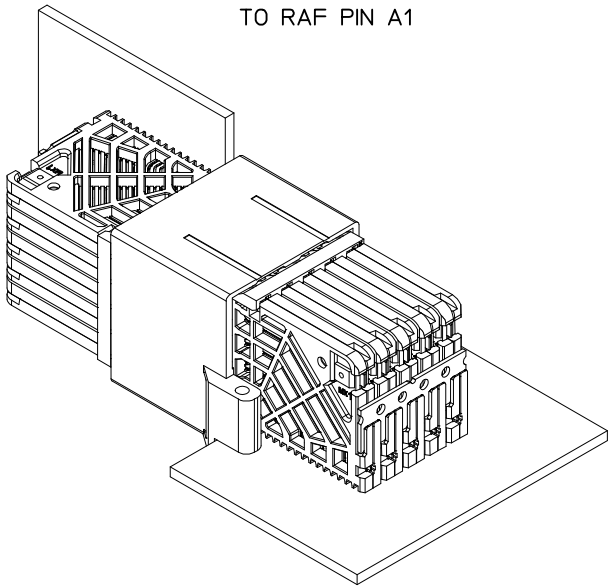

ORTHO PIN MAPPING									
OPTION 270 (NEAR SIDE - FAR SIDE)									
(A1-A1)	A2-B1	(A3-D1)	A4-E1	(A5-G1)	A6-H1	(A7-K1)	A8-L1	(A9-N1)	A10-P1
B1-A2	B2-C1	B3-D2	B4-F1	B5-G2	B6-J1	B7-K2	B8-M1	B9-N2	B10-O1
C1-B2	(C2-C2)	C3-E2	(C4-F2)	C5-H2	(C6-J2)	C7-L2	(C8-M2)	C9-P2	(C10-Q2)
(D1-A3)	D2-B3	(D3-D3)	D4-E3	(D5-G3)	D6-H3	(D7-K3)	D8-L3	(D9-N3)	D10-P3
E1-A4	E2-C3	E3-D4	E4-F3	E5-G4	E6-J3	E7-K4	E8-M3	E9-N4	E10-Q3
F1-B4	(F2-C4)	F3-E4	(F4-F4)	F5-H4	(F6-J4)	F7-L4	(F8-M4)	F9-P4	(F10-Q4)
(G1-A5)	G2-B5	(G3-D5)	G4-E5	(G5-G5)	G6-H5	(G7-K5)	G8-L5	(G9-N5)	G10-P5
H1-A6	H2-C5	H3-D6	H4-F5	H5-G6	H6-J5	H7-K6	H8-M5	H9-N6	H10-Q5
J1-B6	(J2-C6)	J3-E6	(J4-F6)	J5-H6	(J6-J6)	J7-L6	(J8-M6)	J9-P6	(J10-Q6)
(K1-A7)	K2-B7	(K3-D7)	K4-E7	(K5-G7)	K6-H7	(K7-K7)	K8-L7	(K9-N7)	K10-P7
L1-A8	L2-C7	L3-D8	L4-F7	L5-G8	L6-J7	L7-K8	L8-M7	L9-N8	L10-Q7
M1-B8	(M2-C8)	M3-E8	(M4-F8)	M5-H8	(M6-J8)	M7-L8	(M8-M8)	M9-P8	(M10-Q8)
(N1-A9)	N2-B9	(N3-D9)	N4-E9	(N5-G9)	N6-H9	(N7-K9)	N8-L9	(N9-N9)	N10-P9
P1-A10	P2-C9	P3-D10	P4-F9	P5-G10	P6-J9	P7-K10	P8-M9	P9-N10	P10-Q9
Q1-B10	(Q2-C10)	Q3-E10	(Q4-F10)	Q5-H10	(Q6-J10)	Q7-L10	(Q8-M10)	Q9-P10	(Q10-Q10)

NOTE: PINOUTS SHOWN IN BALLOONS ARE GROUNDS.
 GROUND PATHS ARE NOT DISCRETE CIRCUITS.

SEE SHEET 1 EC NO: UCP2016-3973 DRWNG: VARVARA 2015/08/24 CHKD: TELO 2016/02/22 APPR: TELO 2016/04/20 REV: A2	QUALITY SYMBOLS ▽=0 ▽=0	GENERAL TOLERANCES (UNLESS SPECIFIED) <table border="1"> <tr> <th></th> <th>mm</th> <th>INCH</th> </tr> <tr> <td>4 PLACES</td> <td>± .005</td> <td>± .0002</td> </tr> <tr> <td>3 PLACES</td> <td>± .005</td> <td>± .0002</td> </tr> <tr> <td>2 PLACES</td> <td>± 0.13</td> <td>± .005</td> </tr> <tr> <td>1 PLACE</td> <td>± 0.25</td> <td>± .010</td> </tr> </table> ANGULAR ±1/2°		mm	INCH	4 PLACES	± .005	± .0002	3 PLACES	± .005	± .0002	2 PLACES	± 0.13	± .005	1 PLACE	± 0.25	± .010	DIMENSION STYLE MM ONLY	SCALE 2:1	DESIGN UNITS METRIC	THIRD ANGLE PROJECTION
		mm	INCH																		
	4 PLACES	± .005	± .0002																		
	3 PLACES	± .005	± .0002																		
2 PLACES	± 0.13	± .005																			
1 PLACE	± 0.25	± .010																			
DRAWN BY JMENDOZA	DATE 2011/04/11	TITLE IMPACT ORTHOGONAL DIRECT 5 PAIR RAM ASSEMBLY GUIDED SALES DRAWING																			
CHECKED BY JB INGHAM	DATE 2011/04/12	APPROVED BY JB INGHAM		DATE 2011/04/21																	
MATERIAL NO. SEE CHART		DOCUMENT NO. SD-76725-001		SHEET NO. 3 OF 4																	

ORTHO POSITION 90°
 OD-RAM PIN A1 MAPS
 TO RAF PIN Q10

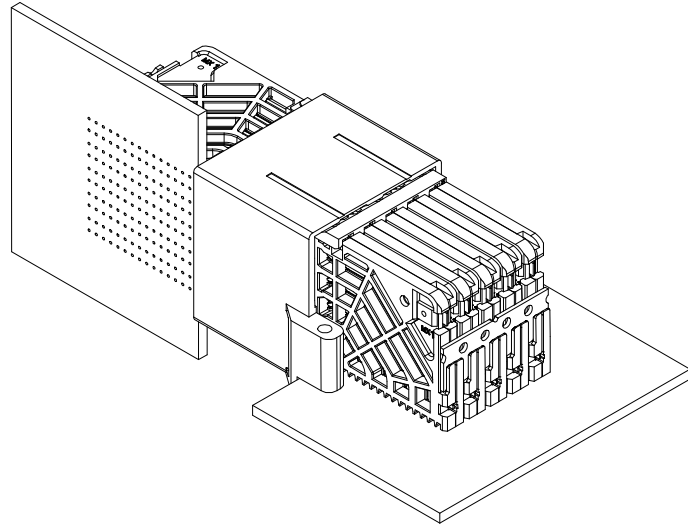

ORTHO PIN MAPPING									
OPTION 90 (NEARSIDE - FAR SIDE)									
(A1-Q10)	A2-P10	(A3-M10)	A4-L10	(A5-J10)	A6-H10	(A7-F10)	A8-E10	(A9-C10)	A10-B10
B1-Q9	B2-N10	B3-M9	B4-K10	B5-J9	B6-G10	B7-F9	B8-D10	B9-C9	B10-A10
C1-P9	(C2-N9)	C3-L9	(C4-K9)	C5-H9	(C6-G9)	C7-E9	(C8-D9)	C9-B9	(C10-A9)
(D1-Q8)	D2-P8	(D3-M8)	D4-L8	(D5-J8)	D6-H8	(D7-F8)	D8-E8	(D9-C8)	D10-B8
E1-Q7	E2-N8	E3-M7	E4-K8	E5-J7	E6-G8	E7-F7	E8-D8	E9-C7	E10-A8
F1-P7	(F2-N7)	F3-L7	(F4-K7)	F5-H7	(F6-G7)	F7-E7	(F8-D7)	F9-B7	(F10-A7)
(G1-Q6)	G2-P6	(G3-M6)	G4-L6	(G5-J6)	G6-H6	(G7-F6)	G8-E6	(G9-C6)	G10-B6
H1-Q5	H2-N6	H3-M5	H4-K6	H5-J5	H6-G6	H7-F5	H8-D6	H9-C5	H10-A6
J1-P5	(J2-N5)	J3-L5	(J4-K5)	J5-H5	(J6-G5)	J7-E5	(J8-D5)	J9-B5	(J10-A5)
(K1-Q4)	K2-P4	(K3-M4)	K4-L4	(K5-J4)	K6-H4	(K7-F4)	K8-E4	(K9-C4)	K10-B4
L1-Q3	L2-N4	L3-M3	L4-K4	L5-J3	L6-G4	L7-F3	L8-D4	L9-C3	L10-A4
M1-P3	(M2-N3)	M3-L3	(M4-K3)	M5-H3	(M6-G3)	M7-E3	(M8-D3)	M9-B3	(M10-A3)
(N1-Q2)	N2-P2	(N3-M2)	N4-L2	(N5-J2)	N6-H2	(N7-F2)	N8-E2	(N9-C2)	N10-B2
P1-Q1	P2-N2	P3-M1	P4-K2	P5-J1	P6-G2	P7-F1	P8-D2	P9-C1	P10-A2
Q1-P1	(Q2-N1)	Q3-L1	(Q4-K1)	Q5-H1	(Q6-G1)	Q7-E1	(Q8-D1)	Q9-B1	(Q10-A1)

NOTE: PINOUTS SHOWN IN BALLOONS ARE GROUNDS.
 GROUND PATHS ARE NOT DISCRETE CIRCUITS.

SEE SHEET 1 EC NO: UCP2016-3973 DRWINDYARVARA 2015/08/24 CHKD:TELO 2016/02/22 APPR:TELO 2016/04/20	QUALITY SYMBOLS 	GENERAL TOLERANCES (UNLESS SPECIFIED)		DIMENSION STYLE MM ONLY	SCALE 2:1	DESIGN UNITS METRIC	THIRD ANGLE PROJECTION	
		4 PLACES ± --- ± ---	3 PLACES ± --- ± ---	DRAWN BY JMENDOZA	DATE 2011/04/11	TITLE IMPACT ORTHOGONAL DIRECT 5 PAIR RAM ASSEMBLY UNGUIDED SALES DRAWING		
		2 PLACES ± 0.13 ± ---	1 PLACE ± 0.25 ± ---	CHECKED BY JB INGHAM	DATE 2011/04/12	APPROVED BY JB INGHAM		
		ANGULAR ± 1/2°		APPROVED BY DATE 2011/04/21		MATERIAL NO. SEE CHART		
A2	REV	DRAFT WHERE APPLICABLE MUST REMAIN WITHIN DIMENSIONS		SIZE C	DOCUMENT NO. SD-76725-001		SHEET NO. 4 OF 4	