

4 CIRCUIT SHOWN

- NOTES:
1. MATERIAL: SEE TABLE
  2. FINISHES: SEE TABLE
  3. PRODUCT SPECIFICATION: NOT REQUIRED
  4. PACKAGING: NOT REQUIRED
  5. MATES WITH: NONE
  6. "XX" REFERS TO THE QUANTITY OF CIRCUITS.

ITEM	QTY.	DESCRIPTION	MATERIAL	FINISH
6	XX	SCREW, #6-32X.250, PHIL-SLOT, SO, WASHER (-50 OPT)	STEEL	ZN, CLEAR CHROMATE
5	XX	SCREW, #6-32X.250, PHIL-SLOT, BHD, (-49 OPT)	BRASS	NICKEL PLATE
4	XX	SCREW, #6-32X.250, PHIL-SLOT, BHD	STEEL	ZN, CLEAR CHROMATE
3	2	PLATE, MTG.	BRASS	NICKEL PLATE
2	XX	TERMINAL, PC	BRASS	TIN PLATE
1	1	INSULATOR, SR, RAISED PADS	THERMOPLASTIC	BLACK

EC NO. RELEASED  
 DRAWN: CLY  
 CHK: APPR:  
 A

QUALITY SYMBOLS  
 MAJOR  
 CRITICAL  
 SPC

GENERAL TOLERANCES: (UNLESS SPECIFIED)

	mm	INCH
4 PLACES	±.0015	
3 PLACES	±.038	±.005
2 PLACES	±.13	±.01
1 PLACE	±.3	

ANGULAR: ±2°

DRAFT WHERE APPLICABLE MUST REMAIN WITHIN DIMENSIONS

SCALE 2:1  
 DESIGN UNITS  
 mm  INCH  
 DRAWN BY & DATE  
 C. YORK 03-01-05  
 CHECKED BY & DATE  
 APPROVED BY & DATE

THIRD ANGLE PROJECTION  
 TITLE:  
 9.53 1.3751 SR BTS, PC ASSY, RAISED PADS

PROJECT NO. -	-	-
DIMENSIONS:	<input checked="" type="checkbox"/> mm <input type="checkbox"/> INCH	<input type="checkbox"/> mm <input type="checkbox"/> INCH ONLY
	SHT	REV
	1	1
	REVISE ON CAD ONLY	
MOLEX INCORPORATED		
CAD FILENAME	MATERIAL NO.	DRAWING NO.
725XX-P	SEE CHART	SD-38720-006
		SHEET NO.
		1 OF 2
THIS DRAWING CONTAINS INFORMATION THAT IS PROPRIETARY TO MOLEX INCORPORATED AND SHOULD NOT BE USED WITHOUT WRITTEN PERMISSION.		SIZE B

NUMBER OF CIRCUITS "XX"	DIM. "A"		DIM. "B"		DIM. "C"		DIM. "D"		ASSEMBLY MATERIAL NO. (-P OPT.)	ASSEMBLY MATERIAL NO. (-P-49 OPT.)	ASSEMBLY MATERIAL NO. (-P-50 OPT.)
02	40.1	[1.58]	9.53	[1.375]	28.58	[1.125]	21.1	[1.83]	387206502	387207102	387207702
03	49.7	[1.96]	19.05	[1.750]	38.10	[1.500]	30.6	[1.21]	387206503	387207103	387207703
04	59.2	[2.33]	28.58	[1.125]	47.63	[1.875]	40.1	[1.58]	387206504	387207104	387207704
05	68.7	[2.71]	38.10	[1.500]	57.15	[2.250]	49.7	[1.96]	387206505	387207105	387207705
06	78.2	[3.08]	47.63	[1.875]	66.68	[2.625]	59.2	[2.33]	387206506	387207106	387207706
07	87.8	[3.46]	57.15	[2.250]	76.20	[3.000]	68.7	[2.71]	387206507	387207107	387207707
08	97.3	[3.83]	66.68	[2.625]	85.73	[3.375]	78.2	[3.08]	387206508	387207108	387207708
09	106.8	[4.21]	76.20	[3.000]	95.25	[3.750]	87.8	[3.46]	387206509	387207109	387207709
10	116.3	[4.58]	85.73	[3.375]	104.78	[4.125]	97.3	[3.83]	387206510	387207110	387207710
11	125.9	[4.96]	95.25	[3.750]	114.30	[4.500]	106.8	[4.21]	387206511	387207111	387207711
12	135.4	[5.33]	104.78	[4.125]	123.83	[4.875]	116.3	[4.58]	387206512	387207112	387207712
13	144.9	[5.71]	114.30	[4.500]	133.35	[5.250]	125.9	[4.96]	387206513	387207113	387207713
14	154.4	[6.08]	123.83	[4.875]	142.88	[5.625]	135.4	[5.33]	387206514	387207114	387207714
15	164.0	[6.46]	133.35	[5.250]	152.40	[6.000]	144.9	[5.71]	387206515	387207115	387207715
16	173.5	[6.83]	142.88	[5.625]	161.93	[6.375]	154.4	[6.08]	387206516	387207116	387207716
17	183.0	[7.21]	152.40	[6.000]	171.45	[6.750]	164.0	[6.46]	387206517	387207117	387207717
18	192.5	[7.58]	161.93	[6.375]	180.98	[7.125]	173.5	[7.21]	387206518	387207118	387207718
19	202.1	[7.96]	171.45	[6.750]	190.50	[7.500]	183.0	[7.58]	387206519	387207119	387207719
20	211.6	[8.33]	180.98	[7.125]	200.03	[7.875]	192.5	[7.96]	387206520	387207120	387207720
21	221.1	[8.71]	190.50	[7.500]	209.55	[8.250]	202.1	[8.33]	387206521	387207121	387207721
22	230.6	[9.08]	200.03	[7.875]	219.08	[8.625]	211.6	[8.71]	387206522	387207122	387207722
23	240.2	[9.46]	209.55	[8.250]	228.60	[9.000]	221.1	[9.08]	387206523	387207123	387207723
24	249.7	[9.83]	219.08	[8.625]	238.13	[9.375]	230.6	[9.46]	387206524	387207124	387207724
25	259.2	[10.21]	228.60	[9.000]	247.65	[9.750]	240.2	[9.83]	387206525	387207125	387207725
26	268.7	[10.58]	238.13	[9.375]	257.18	[10.125]	249.7	[9.83]	387206526	387207126	387207726

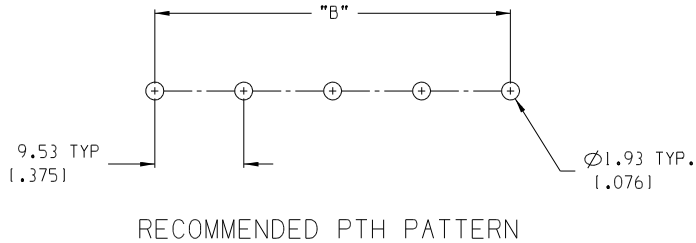

EC NO. : DRAWN: CH-K CHK-K APPR: REV	DESCRIPTION	QUALITY SYMBOLS MAJOR CRITICAL SPC	GENERAL TOLERANCES: (UNLESS SPECIFIED)		SCALE	DESIGN UNITS	THIRD ANGLE PROJECTION	PROJECT NO. -	-	-	
			mm	INCH	-	<input type="checkbox"/> mm <input checked="" type="checkbox"/> INCH	<input checked="" type="checkbox"/> THIRD ANGLE	DIMENSIONS:	SHT	REV	
			4 PLACES	±.0015			<input checked="" type="checkbox"/> mm <input type="checkbox"/> INCH <input type="checkbox"/> mm ONLY				
			3 PLACES	±.038							
			2 PLACES	±.13							
			1 PLACE	±.3							
			ANGULAR: ±2°		DRAWN BY & DATE C. YORK 03-01-05		TITLE: 9.53 [1.375] SR BTS, PC ASSY, RAISED PADS				
			DRAFT WHERE APPLICABLE MUST REMAIN WITHIN DIMENSIONS		CHECKED BY & DATE		APPROVED BY & DATE				
					CAD FILENAME 725XX-P		MATERIAL NO. SEE CHART		DRAWING NO. SD-38720-006		
					THIS DRAWING CONTAINS INFORMATION THAT IS PROPRIETARY TO MOLEX INCORPORATED AND SHOULD NOT BE USED WITHOUT WRITTEN PERMISSION.						SHEET NO. 2 OF 2
											SIZE B

NUMBER OF CIRCUITS "XX"	DIM. A		DIM. B		DIM. C		DIM. D	
	IN	MM	IN	MM	IN	MM	IN	MM
01	1.21	30.7	-	-	.75	19.1	.46	11.7
02	1.58	40.1	.375	9.53	1.13	28.7	.83	21.1
03	1.96	49.7	.750	19.05	1.50	38.1	1.21	30.7
04	2.33	59.2	1.125	28.58	1.88	47.7	1.58	40.1
05	2.71	68.8	1.500	38.10	2.25	57.2	1.96	49.8
06	3.08	78.2	1.875	47.63	2.63	66.8	2.33	59.2
07	3.46	87.9	2.250	57.15	3.00	76.2	2.71	68.8
08	3.83	97.3	2.625	66.68	3.38	85.9	3.08	78.2
09	4.21	106.9	3.000	76.20	3.75	95.3	3.46	87.8
10	4.58	116.3	3.375	85.73	4.13	104.9	3.83	97.3
11	4.96	126.0	3.750	95.25	4.50	114.3	4.21	106.9
12	5.33	135.4	4.125	104.78	4.88	123.9	4.58	116.3
13	5.71	145.0	4.500	114.30	5.25	133.4	4.96	126.0
14	6.08	154.4	4.875	123.83	5.63	143.0	5.33	135.4
15	6.46	164.0	5.250	133.35	6.00	152.4	5.71	145.0
16	6.83	173.5	5.625	142.88	6.38	162.0	6.08	154.4
17	7.21	183.1	6.000	152.40	6.75	171.5	6.46	164.0
18	7.58	192.5	6.375	161.93	7.13	181.1	6.84	173.7
19	7.96	202.2	6.750	171.45	7.50	190.5	7.21	183.1
20	8.33	211.6	7.125	180.98	7.88	200.2	7.58	192.5
21	8.71	221.2	7.500	190.50	8.25	209.6	7.96	202.2
22	9.08	230.6	7.875	200.03	8.63	219.2	8.33	211.6
23	9.46	240.3	8.250	209.55	9.00	228.6	8.71	221.2
24	9.83	249.7	8.625	219.08	9.38	238.2	9.08	230.6
25	10.21	259.3	9.000	228.60	9.75	247.7	9.46	240.3
26	10.58	268.7	9.375	238.13	10.13	257.3	9.83	250.0

### P/N LEGEND

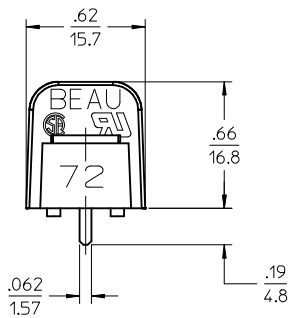
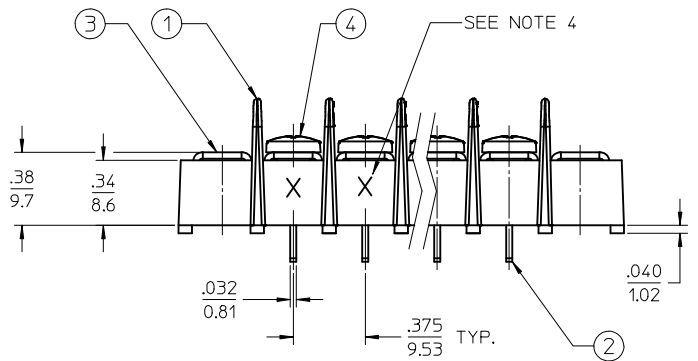
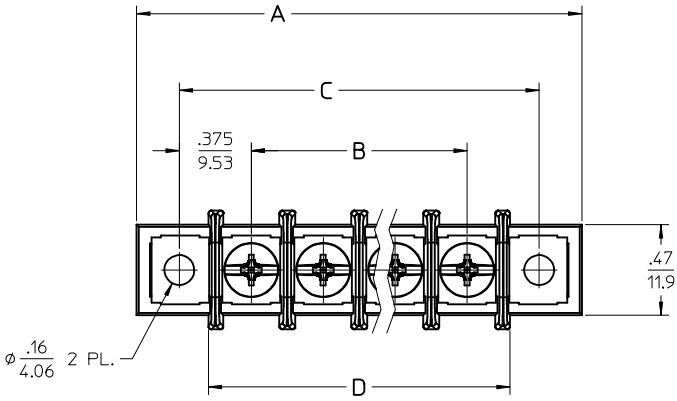
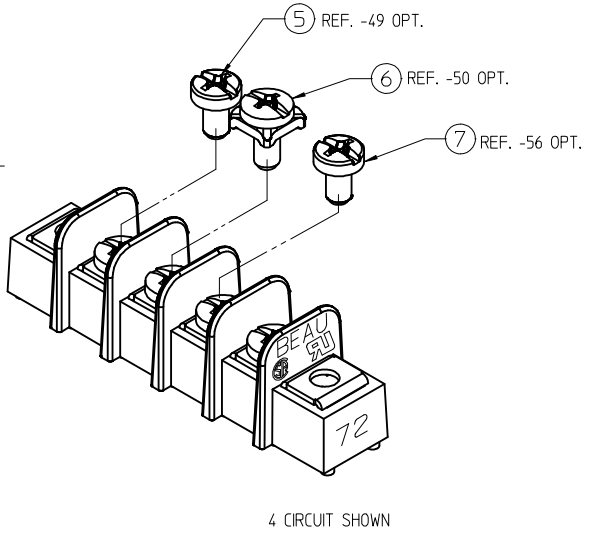
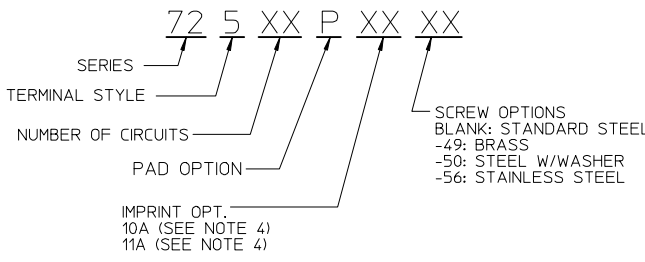

- NOTES:
1. MATERIAL: SEE TABLE
  2. FINISH: SEE TABLE
  3. ELECTRICAL SPECS:  
MAX VOLTAGE: 300V (BINDING HD, 14 AWG)  
MAX CURRENT: 15A  
  
MAX VOLTAGE: 300V (-50 OPT, 12 AWG)  
MAX CURRENT: 25A
  4. REFER TO SD-38120-001 FOR IMPRINT OPTION 10A & 11A
  5. PRODUCT SPEC: PS-38710-001
  6. SCREW TIGHTENING TORQUE: 12 IN LBS. (MAX)
  7. WIRE STRIP LENGTH: .31 (7.8mm)
  8. PART IS RoHS COMPLIANT

7	XX	SCREW, #6-32X.250, PHIL-SLOT, BHD -56 OPT	ST. STEEL	PASSIVATED
6	XX	SCREW, #6-32X.250, PHIL-SLOT, SQ. WASHER (-50 OPT)	STEEL	ZINC, CLEAR CHROMATE
5	XX	SCREW, #6-32X.250, PHIL-SLOT, BHD -49 OPT	BRASS	NICKEL PLATED
4	XX	SCREW, #6-32X.250, PHIL-SLOT, BHD	STEEL	ZINC, CLEAR CHROMATE
3	2	PLATE, MTG.	BRASS	NICKEL PLATED
2	XX	TERMINAL, PC	BRASS	TIN PLATED
1	1	INSULATOR, SR, RAISED PADS	PBT	BLACK
ITEM	QTY.	DESCRIPTION	MATERIAL	FINISH

RELEASED EC NO: IPGZ2015-2082 DRWR:RSTONE 2015/06/04 CHKD:B RUPERT 2015/06/08 APPR:JFMURPHY 2015/06/08	QUALITY SYMBOLS $\nabla=0$ $\nabla=0$	GENERAL TOLERANCES (UNLESS SPECIFIED) <table border="1"> <tr> <th></th> <th>mm</th> <th>INCH</th> </tr> <tr> <td>4 PLACES</td> <td>± .005</td> <td>± .0004</td> </tr> <tr> <td>3 PLACES</td> <td>± .005</td> <td>± .0004</td> </tr> <tr> <td>2 PLACES</td> <td>± .005</td> <td>± .0004</td> </tr> <tr> <td>1 PLACE</td> <td>± .005</td> <td>± .0004</td> </tr> <tr> <td>0 PLACE</td> <td>± .005</td> <td>± .0004</td> </tr> </table>		mm	INCH	4 PLACES	± .005	± .0004	3 PLACES	± .005	± .0004	2 PLACES	± .005	± .0004	1 PLACE	± .005	± .0004	0 PLACE	± .005	± .0004	DIMENSION STYLE IN/MM	SCALE 2:1	DESIGN UNITS INCH	THIRD ANGLE PROJECTION
				mm	INCH																			
4 PLACES	± .005	± .0004																						
3 PLACES	± .005	± .0004																						
2 PLACES	± .005	± .0004																						
1 PLACE	± .005	± .0004																						
0 PLACE	± .005	± .0004																						
DRAFT WHERE APPLICABLE MUST REMAIN WITHIN DIMENSIONS	MATERIAL NO. <b>SEE CHART</b>	DRAWN BY RSTONE	DATE 2015/06/04	CHECKED BY B RUPERT	DATE 2015/06/08	APPROVED BY JFMURPHY	DATE 2015/06/08																	
		ANGULAR ± 1°		DOCUMENT NO. <b>SD-38720-014</b>		SHEET NO. 1 OF 1																		
THIS DRAWING CONTAINS INFORMATION THAT IS PROPRIETARY TO MOLEX INCORPORATED AND SHOULD NOT BE USED WITHOUT WRITTEN PERMISSION																								