

KXW シリーズ  
SERIES

105°C 2000時間 小形化品  
105°C 2000 hours, Miniaturized

RoHS  
compliance

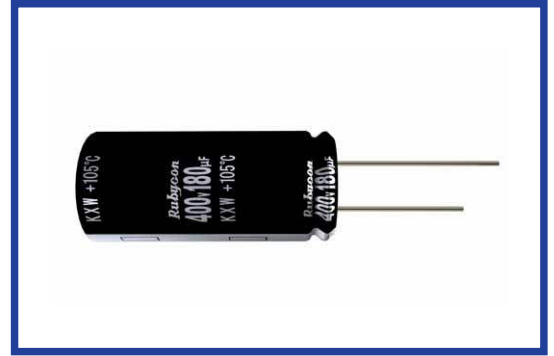

◆規格表 / SPECIFICATIONS

項目 Items	特性 Characteristics				
カテゴリ温度範囲 Category Temperature Range	-25~+105°C				
定格電圧範囲 Rated Voltage Range	200~450Vdc				
静電容量許容差 Capacitance Tolerance	±20% (20°C, 120Hz)				
漏れ電流 Leakage Current(MAX)	$I=3\sqrt{CV}$ 以下 (定格電圧印加5分後) $I=3\sqrt{CV}$ (After 5 minutes application of rated voltage) $I$ =漏れ電流(μA) Leakage Current $C$ =静電容量(μF) Capacitance $V$ =定格電圧(Vdc) Rated Voltage				
損失角の正接 (tanδ) Dissipation Factor(MAX)	定格電圧(Vdc) Rated Voltage	200	400	420~450	(20°C, 120Hz)
	tanδ	0.12	0.15	0.20	
耐久性 Endurance	105°C中で2000時間定格電圧(リップル重畳)印加後、下記項目を満足すること。 After applying rated voltage with rated ripple current for 2000 hours at 105°C, the capacitors shall meet the following requirements.				
	静電容量変化率 Capacitance Change	初期値の±20%以内 Within ±20% of the initial value.			
	損失角の正接 Dissipation Factor	規格値の200%以下 Not more than 200% of the specified value.			
	漏れ電流 Leakage Current	規格値以下 Not more than the specified value.			
低温特性 (インピーダンス比) Impedance Ratio(MAX)	定格電圧(Vdc) Rated Voltage	200	400~450	(120Hz)	
	Z(-25°C)/Z(20°C)	3	8		

◆リップル電流補正係数 / MULTIPLIER FOR RIPPLE CURRENT

周波数(Hz) Frequency	60(50)	120	500	1k	10k≦	
係数 Coefficient	200Vdc	0.80	1.00	1.20	1.30	1.40
	400~450Vdc	0.80	1.00	1.25	1.40	1.50

◆副記号 / OPTION

	記号 Code
PETスリーブ PET Sleeve	EFC

◆呼称方法 / PART NUMBER

□□□	KXW	□□□□□	M	□□□	□□	D×L
定格電圧 Rated Voltage	シリーズ名 Series	静電容量 Capacitance	静電容量許容差 Capacitance Tolerance	副記号 Option	リード加工記号 Lead Forming	ケースサイズ Case Size

◆寸法図 / DIMENSIONS

(mm)

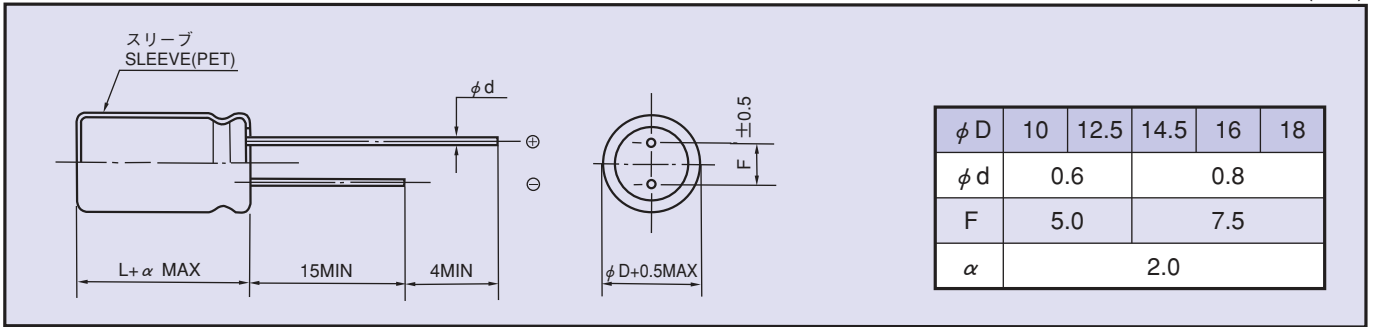

◆標準品一覧表 / STANDARD SIZE

定格電圧 Rated Voltage (Vdc)	静電容量 Capacitance ( $\mu F$ )	外形寸法 Size $\phi D \times L$ (mm)	定格リップル電流 Rated Ripple Current (A r.m.s./105°C,120Hz)
200	82	10×30	0.40
	100	10×35	0.46
	120	10×40	0.53
	150	12.5×30	0.62
	180	12.5×35	0.70
	220	12.5×40	0.80
	220	14.5×30	0.80
	270	14.5×35	0.87
	270	16×30	0.87
	330	16×35	1.01
	330	18×30	1.01
	390	16×40	1.13
	390	18×35	1.13
	470	18×40	1.27
560	18×45	1.39	
400	27	10×30	0.24
	33	10×35	0.28
	39	10×40	0.32
	47	12.5×30	0.37
	56	12.5×35	0.42
	68	12.5×40	0.48
	68	14.5×30	0.48
	82	14.5×35	0.52
	100	14.5×40	0.58
	100	16×30	0.58
	120	16×35	0.67
	120	18×30	0.67
	150	16×40	0.77
	150	18×35	0.77
180	18×40	0.88	
220	18×45	1.00	

定格電圧 Rated Voltage (Vdc)	静電容量 Capacitance ( $\mu F$ )	外形寸法 Size $\phi D \times L$ (mm)	定格リップル電流 Rated Ripple Current (A r.m.s./105°C,120Hz)
420	22	10×30	0.20
	27	10×35	0.23
	33	10×40	0.27
	39	12.5×30	0.31
	47	12.5×35	0.36
	56	12.5×40	0.43
	56	14.5×30	0.43
	68	14.5×35	0.51
	68	16×30	0.51
	82	14.5×40	0.57
	82	16×35	0.57
	100	16×40	0.61
	100	18×30	0.61
	120	18×35	0.66
150	18×40	0.71	
450	18	10×30	0.18
	22	10×35	0.21
	27	10×40	0.25
	33	12.5×30	0.28
	39	12.5×35	0.32
	47	12.5×40	0.38
	47	14.5×30	0.38
	56	14.5×35	0.44
	56	16×30	0.44
	68	14.5×40	0.49
	68	16×35	0.49
	82	16×40	0.55
	82	18×30	0.55
	100	18×35	0.65
120	18×40	0.74	
150	18×45	0.80	