



**ANATECH ELECTRONICS INC**  
RF & Microwave Filters & Products

# Cavity Bandpass Filter

## Part Number: AE1375B9072



### Electrical specifications

**Center Frequency:** 1375 MHz  
**Bandwidth:** 24 MHz  
**Input / Output Impedance:** 50 Ohms  
**Passband:** 1363-1387 MHz  
**Passband Insertion Loss:** @ 1375 MHz: <3dB  
**Passband Ripple:** <0.2 dB  
**Passband Return Loss:** >14 dB  
**Rejection:** >70dB @ 1200 MHz  
**Rejection 2:** >70dB @ 1500 MHz  
**Power Handling:** 40 W

### Mechanical

**Mounting Method:** Threaded Mounting Holes  
**Connector Type:** SMA (M) and SMA (F)  
**Dimensions:** 2" x 1.5" x .550"

### Environmental

**Operating Temperature:** -45 to +85 deg.C  
**Storage Temperature:** -55 to +95 deg.C  
**Shock:** 20 G. 11ms  
**Vibration:** 20 G. 5 to 200 MHz

### Outline Drawing:

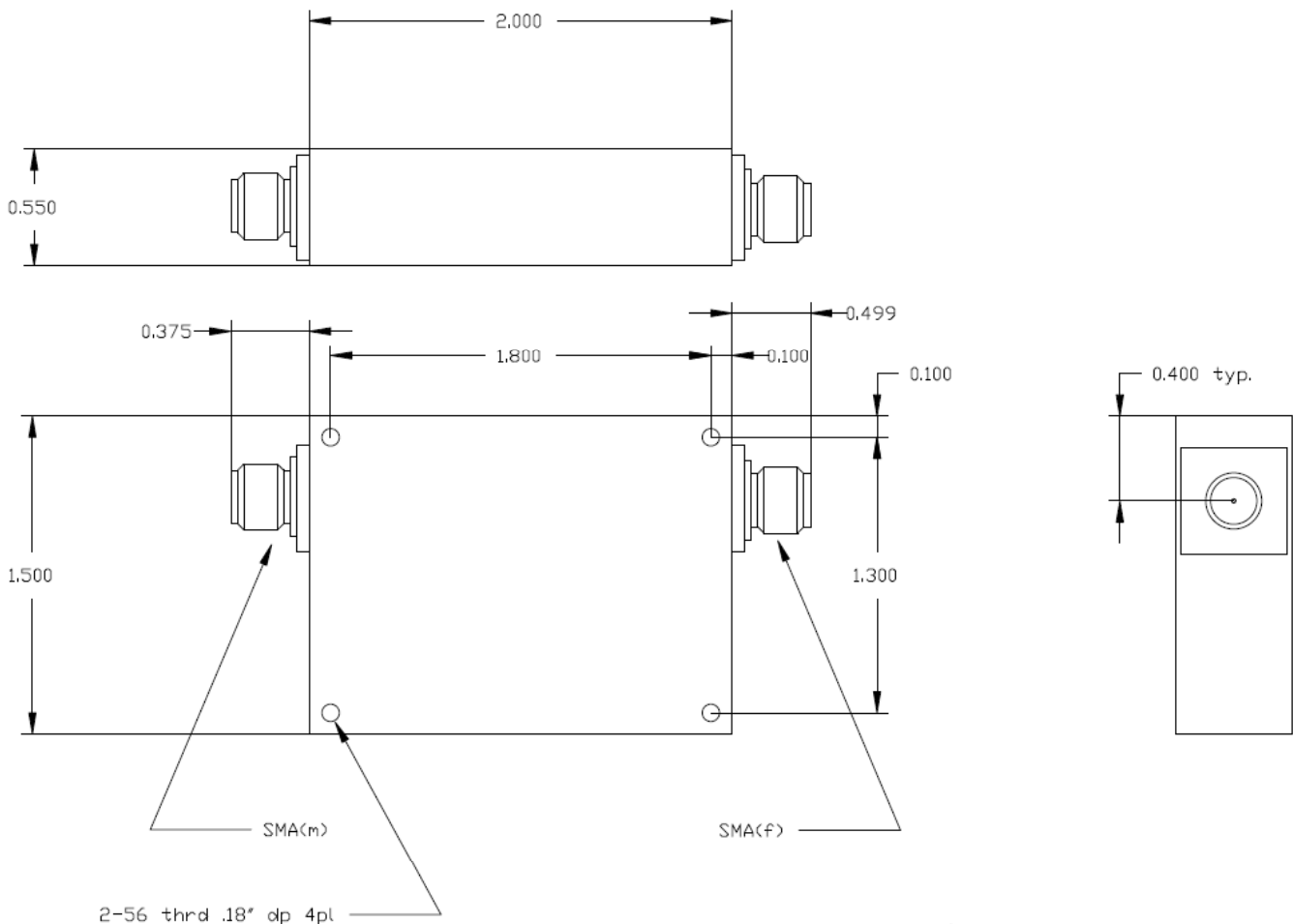



**ANATECH ELECTRONICS INC**  
RF & Microwave Filters & Products

# Cavity Bandpass Filter

## Part Number: AE1375B9072



### Response Plot:

