



FEATURES

- Efficiency up to 86%
- Wide temperature performance at full 2 watt load, -40°C to 85°C
- Dual output from a single input rail
- Industry standard pinout
- Power sharing on output
- 1kVDC isolation 'Hi Pot Test'
- 5V, 12V & 24V inputs
- 5V, 9V, 12V & 15V outputs
- Internal SMD construction
- No external components required
- MTTF up to 1.5 million hours
- No electrolytic or tantalum capacitors
- Pin compatible with MEA1 series

DESCRIPTION

The NMH series of industrial temperature range DC-DC converters are the standard building blocks for on-board point-of-use power systems. They are ideally suited for providing dual rail supplies on single rail boards with the added benefit of galvanic isolation to reduce circuit noise. All of the rated power may be drawn from a single pin provided the total load does not exceed 2 watts.

Pin compatibility with the NMA 1 watt series ensures minimal effort in upgrading distributed power systems.

SELECTION GUIDE

Order Code	Nominal Input Voltage	Output Voltage	Output Current	Input Current at Rated Load	Efficiency	Isolation Capacitance	MTTF ¹	Package Style	Recommended Alternative	
	V	V	mA	mA	%	pF	kHrs			
Recommended In Production										
NMH0509DC	5	±9	±111	494	81	28	663	DIP		
NMH0512DC	5	±12	±83	488	82	30	338			
NMH0515DC	5	±15	±67	476	84	33	187			
NMH0505SC	5	±5	±200	500	80	24	1574		SIP	
NMH0509SC	5	±9	±111	494	81	28	663			
NMH0512SC	5	±12	±83	488	82	30	338			
NMH0515SC	5	±15	±67	476	84	33	187			
NMH1212SC	12	±12	±83	198	84	63	229			
NMH1215SC	12	±15	±67	198	84	66	148			
NMH2405SC	24	±5	±200	103	81	41	318			
NMH2409SC	24	±9	±111	98	85	75	249			
NMH2412SC	24	±12	±83	97	86	95	183			
NMH2415SC	24	±15	±67	97	86	104	127			
To be discontinued										
NMH0505DC	5	±5	±200	500	80	24	1574	DIP	NMK0505SC	
NMH1205DC	12	±5	±200	208	80	35	490		MEJ2D1205SC	
NMH1209DC	12	±9	±111	201	83	55	343		MEJ2S1209SC	
NMH1212DC	12	±12	±83	198	84	63	229		NMK1212SC	
NMH1215DC	12	±15	±67	198	84	66	148		NMK1215SC	
NMH2412DC	24	±12	±83	97	86	95	183	SIP	Contact Murata	
NMH2415DC	24	±15	±67	97	86	104	127		NMK2415SC	
NMH1205SC	12	±5	±200	208	80	35	490		MEJ2D1205SC	
NMH1209SC	12	±9	±111	201	83	55	343	MEJ2S1209SC		
Discontinued										
NMH2405DC	24	±5	±200	103	81	41	318	DIP	Contact Murata	
NMH2409DC	24	±9	±111	98	85	75	249		NMH2409SC	
NMH4805DC	48	±5	±200	51	82	45	235	DIP	Contact Your Local Sales Rep	
NMH4809DC	48	±9	±111	51	82	74	195			
NMH4812DC	48	±12	±83	49	85	90	152			
NMH4815DC	48	±15	±67	49	85	112	112			
NMH4805SC	48	±5	±200	51	82	45	235			
NMH4809SC	48	±9	±111	51	82	74	195	SIP		
NMH4812SC	48	±12	±83	49	85	90	152			
NMH4815SC	48	±15	±67	49	85	112	112			

INPUT CHARACTERISTICS

Parameter	Conditions	Min.	Typ.	Max.	Units
Voltage range	Continuous operation, 5V input types	4.5	5	5.5	V
	Continuous operation, 12V input types	10.8	12	13.2	
	Continuous operation, 24V input types	21.6	24	26.4	
	Continuous operation, 48V input types	43.2	48	52.8	
Reflected ripple current	5V input types		50		mA p-p
	12V input types		70		
	24V input types		130		
	48V input types		200		

1. Calculated using MIL-HDBK-217F with nominal input voltage at full load.

All specifications typical at T_a=25°C, nominal input voltage and rated output current unless otherwise specified.



For full details go to
<https://www.murata.com/en-global/products/power/rohs>

OUTPUT CHARACTERISTICS					
Parameter	Conditions	Min.	Typ.	Max.	Units
Rated Power	T _A =-40°C to 85°C, see derating graph			2	W
Voltage Set Point Accuracy	NMH0505XC	-5		7.5	%
	All other types	-5		5	
Line regulation	High V _{IN} to low V _{IN}		1.0	1.2	%/%
Load Regulation	10% load to rated load, 5V output types		5	10	%
	10% load to rated load, 9V output types		3	10	
	10% load to rated load, 12V output types				
	10% load to rated load, 15V output types				
Ripple and Noise	BW=DC to 20MHz, 5V output types		150	200	mV p-p
	BW=DC to 20MHz, 9V output types		100	150	
	BW=DC to 20MHz, 12V output types		80	150	
	BW=DC to 20MHz, 15V output types		70	150	

ISOLATION CHARACTERISTICS					
Parameter	Conditions	Min.	Typ.	Max.	Units
Isolation test voltage	Flash tested for 1 second	1000			VDC
Resistance	Viso= 500V	1	10		GΩ

GENERAL CHARACTERISTICS					
Parameter	Conditions	Min.	Typ.	Max.	Units
Switching frequency	5V input types		95		kHz
	12V input types		90		
	24V & 48V input types		80		

TEMPERATURE CHARACTERISTICS					
Parameter	Conditions	Min.	Typ.	Max.	Units
Specification	All output types	-40		85	°C
Storage		-50		130	
Case Temperature above ambient	5V output types		30		
	12V output types		25		
Cooling	Free air convection				

ABSOLUTE MAXIMUM RATINGS	
Lead temperature 1.5mm from case for 10 seconds	260°C
Wave Solder	Wave Solder profile not to exceed the profile recommended in IEC 61760-1 Section 6.1.3. Please refer to application notes for further information.
Input voltage V _{IN} , NMH05 types	7V
Input voltage V _{IN} , NMH12 types	15V
Input voltage V _{IN} , NMH24 types	28V
Input voltage V _{IN} , NMH48 types	54V

TECHNICAL NOTES

ISOLATION VOLTAGE

'Hi Pot Test', 'Flash Tested', 'Withstand Voltage', 'Proof Voltage', 'Dielectric Withstand Voltage' & 'Isolation Test Voltage' are all terms that relate to the same thing, a test voltage, applied for a specified time, across a component designed to provide electrical isolation, to verify the integrity of that isolation.

Murata Power Solutions NMH series of DC-DC converters are all 100% production tested at their stated isolation voltage. This is 1kVDC for 1 second.

A question commonly asked is, "What is the continuous voltage that can be applied across the part in normal operation?"

For a part holding no specific agency approvals, such as the NMH series, both input and output should normally be maintained within SELV limits i.e. less than 42.4V peak, or 60VDC. The isolation test voltage represents a measure of immunity to transient voltages and the part should never be used as an element of a safety isolation system. The part could be expected to function correctly with several hundred volts offset applied continuously across the isolation barrier; but then the circuitry on both sides of the barrier must be regarded as operating at an unsafe voltage and further isolation/insulation systems must form a barrier between these circuits and any user-accessible circuitry according to safety standard requirements.

REPEATED HIGH-VOLTAGE ISOLATION TESTING

It is well known that repeated high-voltage isolation testing of a barrier component can actually degrade isolation capability, to a lesser or greater degree depending on materials, construction and environment. The NMH series has toroidal isolation transformers, with no additional insulation between primary and secondary windings of enamelled wire. While parts can be expected to withstand several times the stated test voltage, the isolation capability does depend on the wire insulation. Any material, including this enamel (typically polyurethane) is susceptible to eventual chemical degradation when subject to very high applied voltages thus implying that the number of tests should be strictly limited. We therefore strongly advise against repeated high voltage isolation testing, but if it is absolutely required, that the voltage be reduced by 20% from specified test voltage.

This consideration equally applies to agency recognised parts rated for better than functional isolation where the wire enamel insulation is always supplemented by a further insulation system of physical spacing or barriers.

RoHS COMPLIANCE INFORMATION



This series is compatible with RoHS soldering systems with a peak wave solder temperature of 260°C for 10 seconds. Please refer to [application notes](#) for further information. The pin termination finish on the SIP package type is Tin Plate, Hot Dipped over Matte Tin with Nickel Preplate. The DIP types are Matte Tin over Nickel Preplate. Both types in this series are backward compatible with Sn/Pb soldering systems. For further information, please visit www.murata-ps.com/rohs

PART NUMBER STRUCTURE

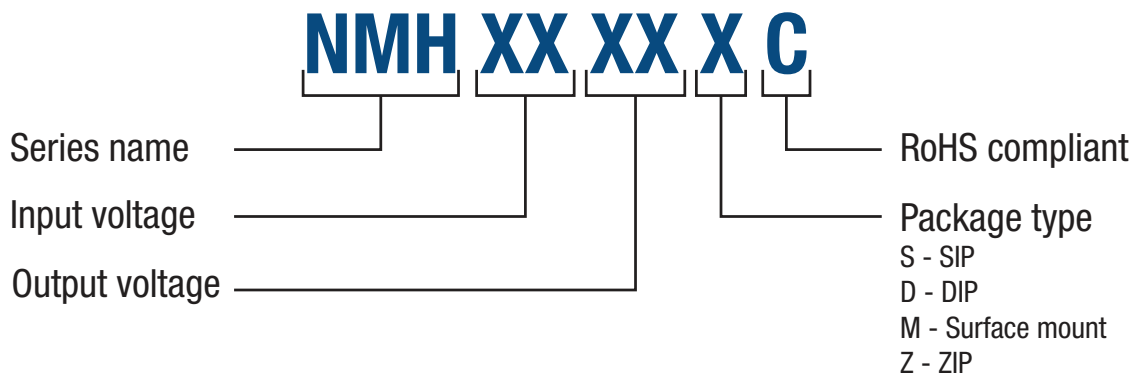

CHARACTERISATION TEST METHODS

Ripple & Noise Characterisation Method

Ripple and noise measurements are performed with the following test configuration.

C1	1µF X7R multilayer ceramic capacitor, voltage rating to be a minimum of 3 times the output voltage of the DC-DC converter
C2	10µF tantalum capacitor, voltage rating to be a minimum of 1.5 times the output voltage of the DC-DC converter with an ESR of less than 100mΩ at 100 kHz
C3	100nF multilayer ceramic capacitor, general purpose
R1	450Ω resistor, carbon film, ±1% tolerance
R2	50Ω BNC termination
T1	3T of the coax cable through a ferrite toroid
RLOAD	Resistive load to the maximum power rating of the DC-DC converter. Connections should be made via twisted wires

Measured values are multiplied by 10 to obtain the specified values.

Differential Mode Noise Test Schematic

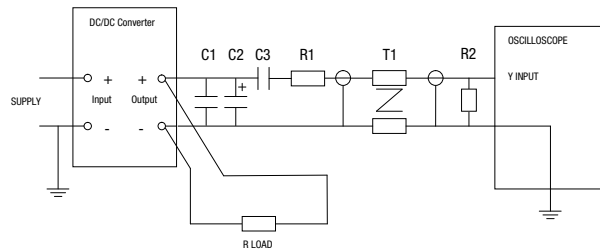

APPLICATION NOTES

Minimum load

The minimum load to meet datasheet specification is 10% of the full rated load across the specified input voltage range. Lower than 10% minimum loading will result in an increase in output voltage, which may rise to typically double the specified output voltage if the output load falls to less than 5%.

Capacitive loading and start up

Typical start up times for this series, with a typical input voltage rise time of 2.2µs and output capacitance of 10µF, are shown in the table below. The product series will start into a capacitance of 47µF with an increased start time, however, the maximum recommended output capacitance is 10µF.

	Start-up time µs		Start-up time µs
NMH0505XC	1072	NMH2405XC	1064
NMH0509XC	2481	NMH2409XC	1544
NMH0512XC	3546	NMH2412XC	4398
NMH0515XC	5380	NMH2415XC	4230
NMH1205XC	672	NMH4805XC	966
NMH1209XC	1152	NMH4809XC	1220
NMH1212XC	1580	NMH4812XC	2822
NMH1215XC	3150	NMH4815XC	4275

Typical Start-Up Wave Form

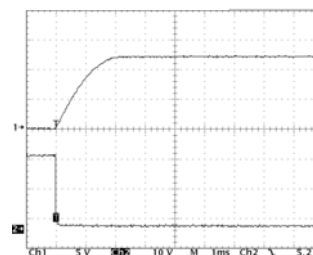

APPLICATION NOTES (Continued)

Output Ripple Reduction

By using the values of inductance and capacitance stated, the output ripple at the rated load is lowered to 5mV p-p max.

Component selection

Capacitor: It is required that the ESR (Equivalent Series Resistance) should be as low as possible, ceramic types are recommended.

The voltage rating should be at least twice (except for 15V output), the rated output voltage of the DC-DC converter.

Inductor: The rated current of the inductor should not be less than that of the output of the DC-DC converter. At the rated current, the DC resistance of the inductor should be such that the voltage drop across the inductor is <2% of the rated voltage of the DC-DC converter. The SRF (Self Resonant Frequency) should be >20MHz.

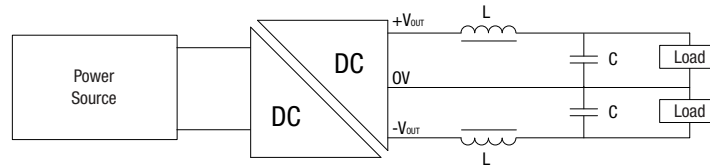

Order Code	L (μH)	Inductor Order Codes		C (μF)
		SMD	Through Hole	
NMH0505XC	47	82473C	11R473C	4.7
NMH0509XC	47	82473C	11R473C	2.2
NMH0512XC	150	82154C	11R154C	3.3
NMH0515XC	100	82104C	11R104C	3.3
NMH1205XC	47	82473C	11R473C	4.7
NMH1209XC	47	82473C	11R473C	2.2
NMH1212XC	150	82154C	11R154C	3.3
NMH1215XC	100	82104C	11R104C	3.3
NMH2405XC	47	82473C	11R473C	4.7
NMH2409XC	47	82473C	11R473C	2.2
NMH2412XC	150	82154C	11R154C	3.3
NMH2415XC	100	82104C	11R104C	3.3
NMH4805XC	47	82473C	11R473C	4.7
NMH4809XC	47	82473C	11R473C	2.2
NMH4812XC	150	82154C	11R154C	3.3
NMH4815XC	100	82104C	11R104C	3.3

Product specification for MPS inductors can be found at:

1100R Series (Through Hole)

http://www.murata-ps.com/data/magnetics/kmp_1100r.pdf

8200 Series (SMD)

http://www.murata-ps.com/data/magnetics/kmp_8200c.pdf

TOLERANCE ENVELOPES

The voltage tolerance envelopes show typical load regulation characteristics for this product series. The tolerance envelope is the maximum output voltage variation due to the changes in output loading.

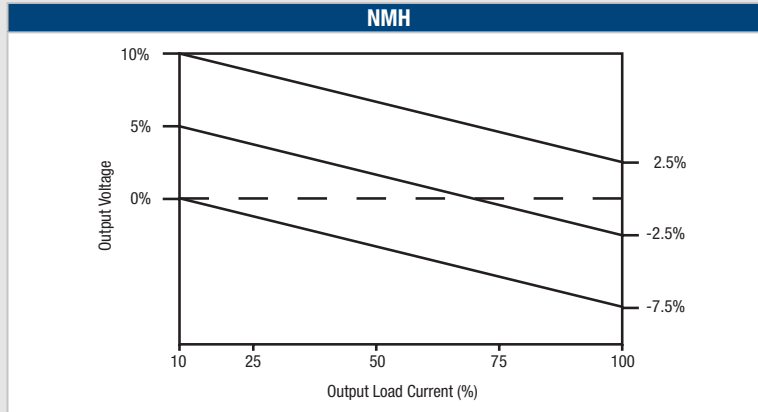

TEMPERATURE DERATING GRAPH

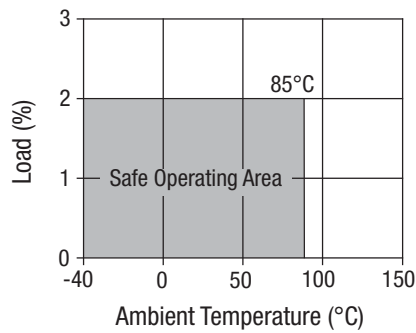

PACKAGE SPECIFICATIONS

MECHANICAL DIMENSIONS

DIP package

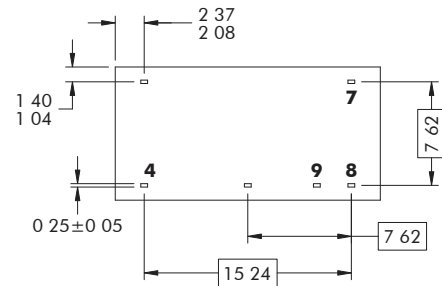
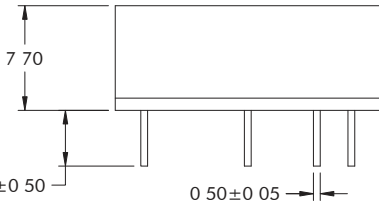
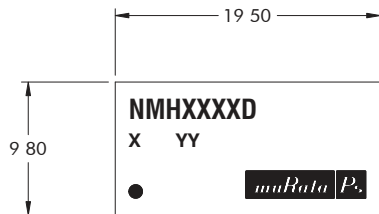

SIP package

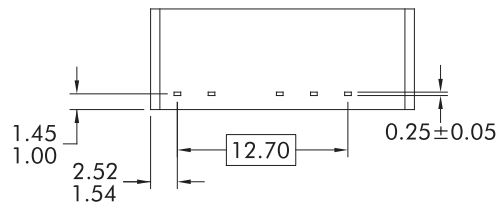
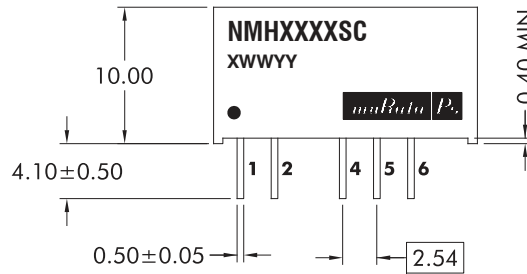
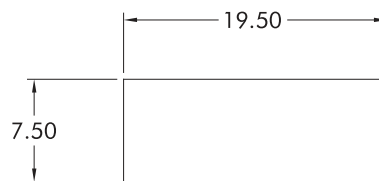

Unless otherwise stated all dimensions in mm ±0.25mm.
All pins on a 2.54mm pitch and within 0.25mm of true position.

Weight: 2.85g (DIP) 2.76g (SIP)

PIN CONNECTIONS - 14 PIN DIP

Pin	Function
1	-VIN
7	NC
8	OV
9	+VOUT
11	-VOUT
14	+VIN

PIN CONNECTIONS - 7 PIN SIP

Pin	Function
1	+VIN
2	-VIN
4	-VOUT
5	OV
6	+VOUT

PACKAGE SPECIFICATIONS (Continued)

RECOMMENDED FOOTPRINT DETAILS

14 Pin DIP Package

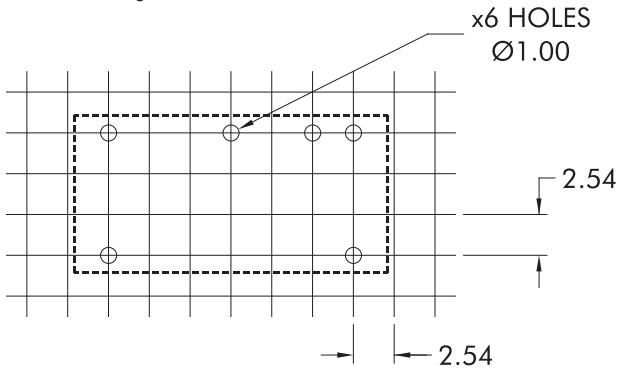

7 Pin SIP Package

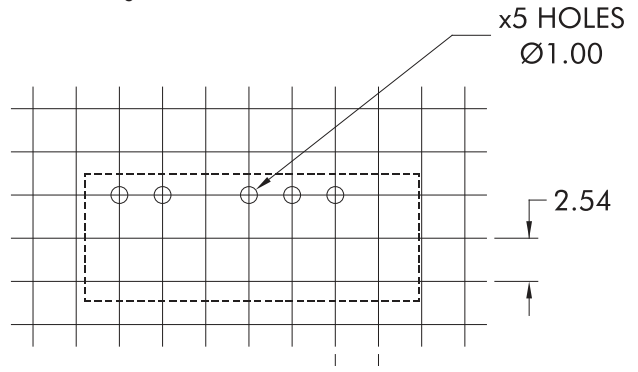

TUBE OUTLINE DIMENSIONS

14 Pin DIP Tube

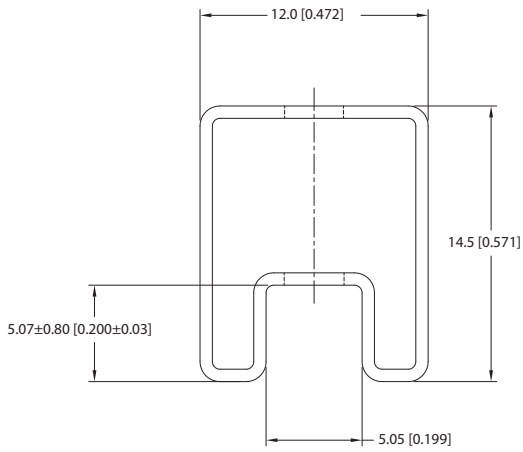

7 Pin SIP Tube

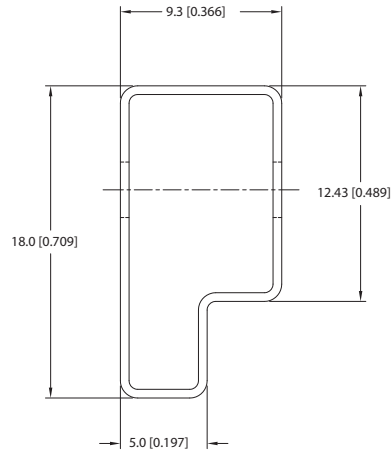

Unless otherwise specified all dimensions in mm [inches] ±0.55mm [0.022]. Tube length (14 Pin DIP) : 520mm [20.472] ±2.0 [0.079]. Tube length (7 Pin SIP) : 520mm [20.472] ±2.0 [0.079].

Tube Quantity : 25

DISCLAIMER

Unless otherwise stated in the datasheet, all products are designed for standard commercial and industrial applications and NOT for safety-critical and/or life-critical applications.

Particularly for safety-critical and/or life-critical applications, i.e. applications that may directly endanger or cause the loss of life, inflict bodily harm and/or loss or severe damage to equipment/property, and severely harm the environment, a prior explicit written approval from Murata is strictly required. Any use of Murata standard products for any safety-critical, life-critical or any related applications without any prior explicit written approval from Murata shall be deemed unauthorised use.

These applications include but are not limited to:

- Aircraft equipment
- Aerospace equipment
- Undersea equipment
- Power plant control equipment
- Medical equipment
- Transportation equipment (automobiles, trains, ships, etc.)
- Traffic signal equipment
- Disaster prevention / crime prevention equipment
- Data Processing equipment

Murata makes no express or implied warranty, representation, or guarantee of suitability, fitness for any particular use/purpose and/or compatibility with any application or device of the buyer, nor does Murata assume any liability whatsoever arising out of unauthorised use of any Murata product for the application of the buyer. The suitability, fitness for any particular use/purpose and/or compatibility of Murata product with any application or device of the buyer remain to be the responsibility and liability of the buyer.

Buyer represents and agrees that it has all the necessary expertise to create and implement safeguards that anticipate dangerous consequences of failures, monitor failures and their consequences, lessen the likelihood of failures that might cause harm, and take appropriate remedial actions. Buyer will fully indemnify and hold Murata, its affiliated companies, and its representatives harmless against any damages arising out of unauthorised use of any Murata products in any safety-critical and/or life-critical applications.

Remark: Murata in this section refers to Murata Manufacturing Company and its affiliated companies worldwide including, but not limited to, Murata Power Solutions.



This product is subject to the following [operating requirements](https://www.murata.com/en-eu/products/power/requirements) and the [Life and Safety Critical Application Sales Policy](https://www.murata.com/en-eu/products/power/requirements):

Refer to: <https://www.murata.com/en-eu/products/power/requirements>

Murata Power Solutions (Milton Keynes) Ltd. makes no representation that the use of its products in the circuits described herein, or the use of other technical information contained herein, will not infringe upon existing or future patent rights. The descriptions contained herein do not imply the granting of licenses to make, use, or sell equipment constructed in accordance therewith. Specifications are subject to change without notice.

© 2022 Murata Power Solutions (Milton Keynes) Ltd.