

PART NUMBER	REVISION	DESCRIPTION	FEED TYPE
2151139-1	F	FINE CRIMP HEIGHT ADJUST	MECHANICAL
2151139-2	F	FINE CRIMP HEIGHT ADJUST	PNEUMATIC
5-2151139-1	F	SEAL STRIPPER CRIMPER TERMINATING UNIT	MECHANICAL
5-2151139-2	F	SEAL STRIPPER CRIMPER TERMINATING UNIT	PNEUMATIC
7-2151139-1	F	MECHANICAL AND CRIMP TOOLING KIT	MECHANICAL
7-2151139-2	F	PNEUMATIC AND CRIMP TOOLING KIT	PNEUMATIC
7-2151139-7	F	CRIMP TOOLING KIT	-

ATLANTIC VERSION TERMINATOR INTERFACE ADAPTER



APPLICATOR DATA		
CRIMP	SIZE	TYPE
WIRE	2.03 mm [.080]	F
INSUL	4.06 mm [1.60]	O

APPLICATOR INSTRUCTIONS
408-35042

TERMINAL DATA: TE TERMINAL		TE CRIMP SPECIFICATION	
TERMINAL NAME: DIA 1.5mm PIN or SOCKET CONTACT, SINGLE WIRE			
WIRE STRIP LENGTH		TERMINAL INSULATION DIAMETER RANGE	
4.20-4.80 mm [1.65-.189 IN]		∅ 3.4mm MAX	
TERMINAL APPLICATION SPECIFICATION	(A)114-18040 (B)114-18020	-	-

TERMINALS APPLIED				SEAL INSULATION DIAMETER RANGE
TE TERMINAL	TE TERMINAL	TE SEAL	TE SEAL	∅ 1.2-2.1mm
(A) 929989-1	(B) 929974-9		(A) 828904-1	
(A) 929989-4	(B) 1-929974-4		(A) 828904-2	
(A) 929989-7	(A) 1-1418497-0		(A) 828904-3	
(A) 929989-8	(B) 929967-1		(B) 828920-1	
(A) 1-929989-0	(B) 929967-7		(B) 828920-2	
(B) 929974-1	(B) 929967-8			
(B) 929974-4	(B) 1-929967-0			

WIRE SIZE	CRIMP HEIGHT mm [INCH]	CRIMP HEIGHT REFERENCE SETTING
1.00mm2	1.45 +/- 0.03 [0.057 +/- .001]	3.7
0.75mm2	1.36 +/- 0.03 [0.054 +/- .001]	4.5
0.50mm2	1.27 +/- 0.03 [0.050 +/- .001]	5.5

- RECOMMENDED SPARE PARTS
- REFER TO SUPPLIED INSTRUCTION SHEET FOR CLEANING, LUBRICATION AND STORAGE OF APPLICATOR.
- APPLY PART NUMBER 1-23419-5 LOCTITE TO THREADS OF ITEMS 180. APPLY PART NUMBER 2-23419-6 LOCTITE TO THREADS OF ITEM 242.
- CRIMP HEIGHT REFERENCE SETTING WAS THE SETTING USED WHEN THE APPLICATOR WAS QUALIFIED AT THE FACTORY. ADJUSTMENT MAY BE NECESSARY WHEN RUNNING APPLICATOR IN THE FIELD.
- APPLY TORQ-SEAL IN ALLEN SOCKET TO FILL HOLE AFTER FLAT HD HAS BEEN ADJUSTED TO CORRECT HEIGHT AT QUALIFICATION. APPLY #1-23419-5 LOC-TITE TO THREADS.
- TERMINAL LUBRICANT IS RECOMMENDED.
- UNLESS SPECIFIED OTHERWISE TORQUE VALUES SHALL BE USED PER DOCUMENT, 101-35000.
- THIS CRIMP PARAMETER IS PROVIDED TO MEET A CUSTOM AND UNIQUE CUSTOMER REQUIREMENT. IT HAS BEEN EVALUATED AND IS CONDITIONALLY SPECIFIED BY TE CONNECTIVITY. THIS CUSTOMIZED CRIMP PARAMETER IS NOT LISTED AS AN APPROVED APPLICATION WITHIN A TE CONNECTIVITY APPLICATION SPECIFICATION. **TE CONNECTIVITY EXPRESSLY DISCLAIMS ANY AND ALL WARRANTIES THAT THE PRODUCT WILL PERFORM SIMILARLY TO VALIDATED AND APPROVED APPLICATIONS. AS STATED WITHIN TE CONNECTIVITY APPLICATION SPECIFICATIONS, INCLUDING BUT NOT LIMITED TO IMPLIED WARRANTIES OF MERCHANTABILITY OR FITNESS FOR PARTICULAR PURPOSE.** AS SUCH, IT IS HIGHLY RECOMMENDED THAT THE CUSTOMER PERFORM FURTHER DETAILED EVALUATION TO ASSESS PRODUCT PERFORMANCE IN THE SPECIFIC APPLICATION.

***WARNING**
ON INSTALLATION, SET WIRE DISC TO CRIMP HEIGHT REFERENCE SETTING FOR LARGEST WIRE SIZE. CRIMP HEIGHT REFERENCE SETTINGS GREATER THAN THE VALUE SHOWN MAY CAUSE DAMAGE TO THE CRIMP TOOLING. REFER TO THE INSTRUCTION SHEET FOR PROPER SETUP AND ADJUSTMENTS.

TERMINAL DATA: TE TERMINAL		TE CRIMP SPECIFICATION	
TERMINAL NAME: DIA 1.5mm PIN or SOCKET CONTACT, SINGLE WIRE			
WIRE STRIP LENGTH		TERMINAL INSULATION DIAMETER RANGE	
4.20-4.80 mm [1.65-.189 IN]		∅ 1.2-2.1mm	
TERMINAL APPLICATION SPECIFICATION	(A)114-18040 (B)114-18020	-	-

TERMINALS APPLIED				SEAL INSULATION DIAMETER RANGE
TE TERMINAL	TE TERMINAL	TE SEAL	TE SEAL	∅ 1.2-2.1mm
(A) 1703013-1			(A) 828904-1	
(A) 1703013-2			(A) 828904-2	
(A) 1703013-4			(A) 828904-3	
(A) 1703013-8			(B) 828920-1	
(A) 1703049-1			(B) 828920-2	

TERMINAL DATA: TE TERMINAL		TE CRIMP SPECIFICATION	
TERMINAL NAME: DIA 1.5mm PIN or SOCKET CONTACT, SINGLE WIRE			
WIRE STRIP LENGTH		TERMINAL INSULATION DIAMETER RANGE	
4.20-4.80mm [1.65-.189 IN]		∅ 3.4mm MAX	
TERMINAL APPLICATION SPECIFICATION	(B)114-18020	-	-

TERMINALS APPLIED				SEAL INSULATION DIAMETER RANGE
TE TERMINAL	TE TERMINAL	TE SEAL	TE SEAL	∅ 1.2-2.1mm
(B) 929974-1	(B) 929974-8		(B) 828920-1	
(B) 929974-4	(B) 929974-9		(B) 828920-2	
(B) 929974-7	(B) 1-929974-4			

WIRE SIZE	CRIMP HEIGHT mm [INCH]	CRIMP HEIGHT REFERENCE SETTING
18 AWG	1.29 +/- 0.05 [0.051 +/- .002]	5.3

ATLANTIC VERSION
Shown on sheets 1 of 4 & 2 of 4
(Pacific version shown on sheets 3 of 4 & 4 of 4)

LOC	DIST	REVISIONS			
A	66	REV	DATE	BY	APPD
		D1	ECR-19-001926	05FEB2019	LG GB
		E	ECR-19-006162	16APR2019	LG TE
		F	ECR-21-123975	14DEC2021	JWC TE
		F1	ECR-22-159878	30NOV2022	FZ GB

-	-	-	1	1	-	-	1803515-3	RAM ASSEMBLY, SF ATLANTIC	293
-	-	-	1	1	-	-	2-1803583-1	APPLICATOR BASIC ASSEMBLY, SF	292
-	1	-	1	-	1	-	2119641-1	FEED CAM, AIR FEED	248
-	1	1	1	1	1	1	2119082-9	CAM, SNAIL, INSULATION ADJUSTMENT	244
-	1	1	1	1	1	1	2079764-1	WASHER, WAVE SPRING, CREST-TO-CREST	243
-	1	1	1	1	1	1	2119083-1	RETAINER, INSULATION DIAL	242
-	1	1	1	1	1	1	7-18023-7	SCR, SKT HD CAP M3 X 4.0	241
-	-	1	-	1	-	1	2119580-1	MECHANICAL FEED ASSEMBLY	239
-	1	-	1	-	1	-	2844940-1	AIR FEED MODULE	238
-	-	-	1	1	-	-	4-1722335-3	STRIPPER, SIDE FEED	182
-	-	-	1	1	-	-	1-5018030-0	NUT, HEX, REG, RoHS, M3.5	181
-	-	-	1	1	-	-	2-1752354-2	STANDOFF, HOLD-DOWN	180
-	-	-	1	1	-	-	993111-1	PIN, SLOTTED SPRING 3.0 X 20.0	177
-	-	-	1	1	-	-	5-22280-0	SPRING, COMPRESSION	176
-	-	-	1	1	-	-	1752353-3	GUIDE PIN, HOLDDOWN	175
-	-	-	1	1	-	-	1901680-2	GUIDE PIN, HOLDDOWN	174
-	REF	REF	REF	REF	REF	REF	994970-2	COUNTER, MAGNETIC	164
-	1	1	1	1	1	1	2119955-1	ASSY, LUBRICATOR, SIDE FEED	113
-	1	1	1	1	1	1	2844908-1	SCREW, LOCKING	99
-	1	1	1	1	1	1	2844907-1	POST, LOCKING	98
-	1	1	1	1	1	1	455888-5	SPACER, CRIMPER	82
-	1	1	1	1	1	1	1803607-3	DOCUMENTATION PACKAGE	71
-	1	1	1	1	1	1	1803948-6	DEPRESSOR, WIRE, SPECIAL	70
-	1	1	1	1	1	1	2119740-1	TAG, IDENTIFICATION	67
-	2	2	2	2	2	2	2168078-1	SCREW, DRIVE, RH, RoHS, 2 x .188	66
-	1	1	1	1	1	1	2168083-2	SCR, SKT HD CAP, RoHS, M4 X 8.0	60
-	1	1	1	1	1	1	5-18022-5	SCR, HEX HD CAP, M4 X 6.0	59
-	1	1	1	1	1	1	985575-3	SCR, FLT SKT HD CAP M3 X 10.0	57
-	1	1	1	1	1	1	1338685-1	PAWL, FEED	56
-	4	4	4	4	4	4	2168083-3	SCR, SKT HD CAP, RoHS, M4 X 12.0	54
-	2	2	2	2	2	2	2168083-3	SCR, SKT HD CAP, RoHS, M4 X 12.0	53
-	1	1	1	1	1	1	5018030-1	NUT, HEX, REG, RoHS, M3	52
-	1	1	1	1	1	1	811242-5	BUMPER, HOLD DOWN	51
-	1	1	1	1	1	1	690753-2	SPACER, TONKER	50
-	1	2	1	2	1	2	18023-9	SCR, SKT HD CAP M4 X 6.0	49
-	-	1	-	1	-	1	2119652-1	FEED CAM, PRE FEED	48
-	-	1	-	1	-	1	2119653-1	FEED CAM, POST FEED	47
-	1	1	-	-	1	1	1803583-9	APPLICATOR BASIC ASSEMBLY, SF	46
-	1	1	-	-	1	1	1803515-1	RAM ASSEMBLY, SF ATLANTIC	44
-	1	1	1	1	1	1	1803602-1	SCR, BHSC, RoHS (M8 X 25)	41
-	1	1	1	1	1	1	1-1752356-7	SUPPORT, TERMINAL	34
-	2	2	2	2	2	2	2079383-5	SCR, BHSC, RoHS (M4 X 20)	33
-	2	2	2	2	2	2	2-2844962-8	SPACER, CYLINDRICAL, STRIP GUIDE	30
-	1	1	1	1	1	1	2844992-1	ASSEMBLY, STRIP GUIDE	29
-	1	1	1	1	1	1	455888-5	SPACER, CRIMPER	28
-	1	1	1	1	1	1	1320928-6	STRIP GUIDE	24
-	1	1	-	-	1	1	2168083-2	SCR, SKT HD CAP, RoHS, M4 X 8.0	21
-	2	2	1	1	2	2	1-18028-2	WASHER, FLAT, REG M4	20
-	1	1	-	-	1	1	2119533-1	STRIPPER, SIDE FEED	19
-	1	1	1	1	1	1	2119806-1	INSERT, SHEAR	13
-	1	1	1	1	1	1	3-22280-3	SPRING, COMPRESSION	12
-	1	1	1	1	1	1	1-356885-4	STOP, SHEAR	11
-	1	1	1	1	1	1	2119805-1	SHEAR HOLDER, FRONT	10
-	1	1	1	1	1	1	318707-1	FLOATING SHEAR, FRONT	9
1	2	2	1	1	1	1	1338693-1	ANVIL, COMBINATION .080	8
-	1	1	1	1	1	1	3-240641-8	SPACER	7
-	1	1	1	1	1	1	2119781-1	DEPRESSOR, SHEAR	5
-	1	1	1	1	1	1	3-238011-3	BLOCK, CRIMPER SPACER	4
1	2	2	1	1	1	1	2-1803019-4	CRIMPER, INSULATION O	3
-	1	1	1	1	1	1	455888-6	SPACER, CRIMPER	2
1	2	2	1	1	1	1	1633730-5	CRIMPER, WIRE	1

ITEM NO	PART NO	DESCRIPTION	ITEM NO
-77	-72	-71	-52
-51	-2	-1	

DATE	BY	APPD	NAME	SIZE	CAGE CODE	DRAWING NO	RESTRICTED TO
13OCT2011	H. HUANG	S. XI	J. CRUZ	A1	00779	2151139	-

Customer Accessible Production Drawing SCALE 1:2 SHEET 1 of 4 REV F1

LOC	DIST	REVISIONS			
A	66	REV	DATE	BY	APPV
-	-	SEE SHEET 1	-	-	-

FEED TYPE MECHANICAL

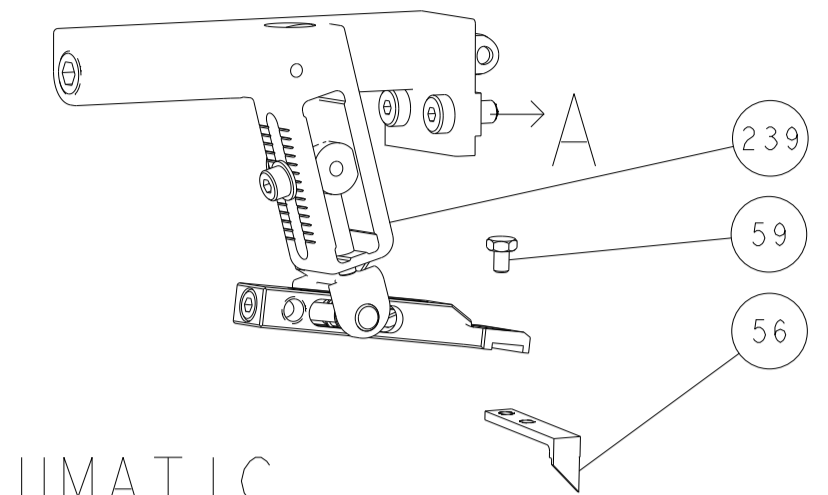

PNEUMATIC

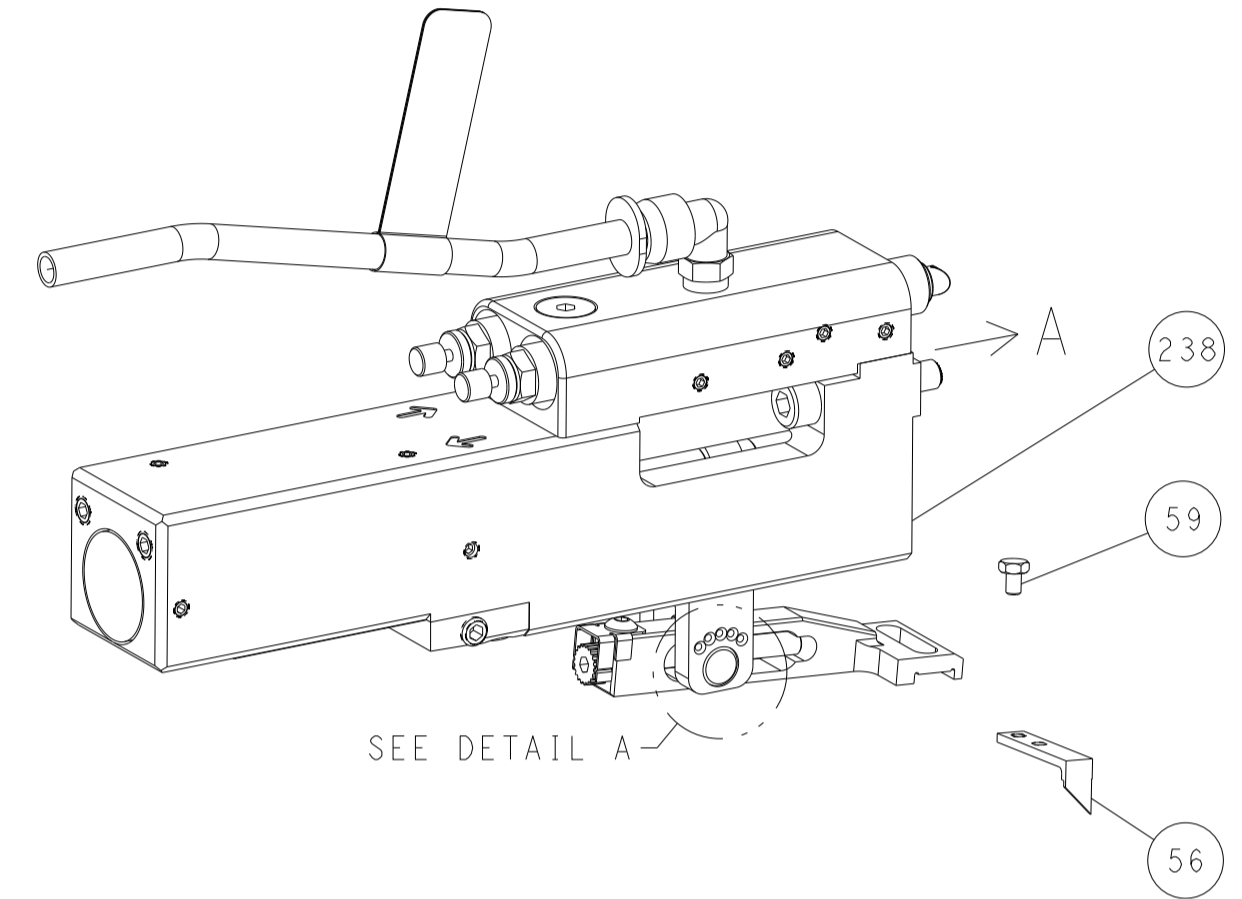

FEED SPRING SETTING POSITION (SHOWN FROM REAR SIDE)

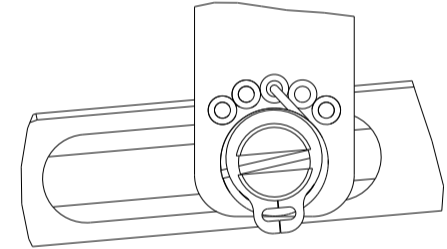

DETAIL A

CAM POSITIONS

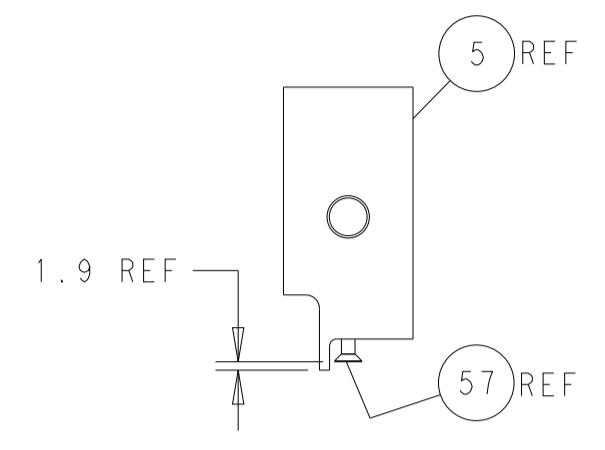
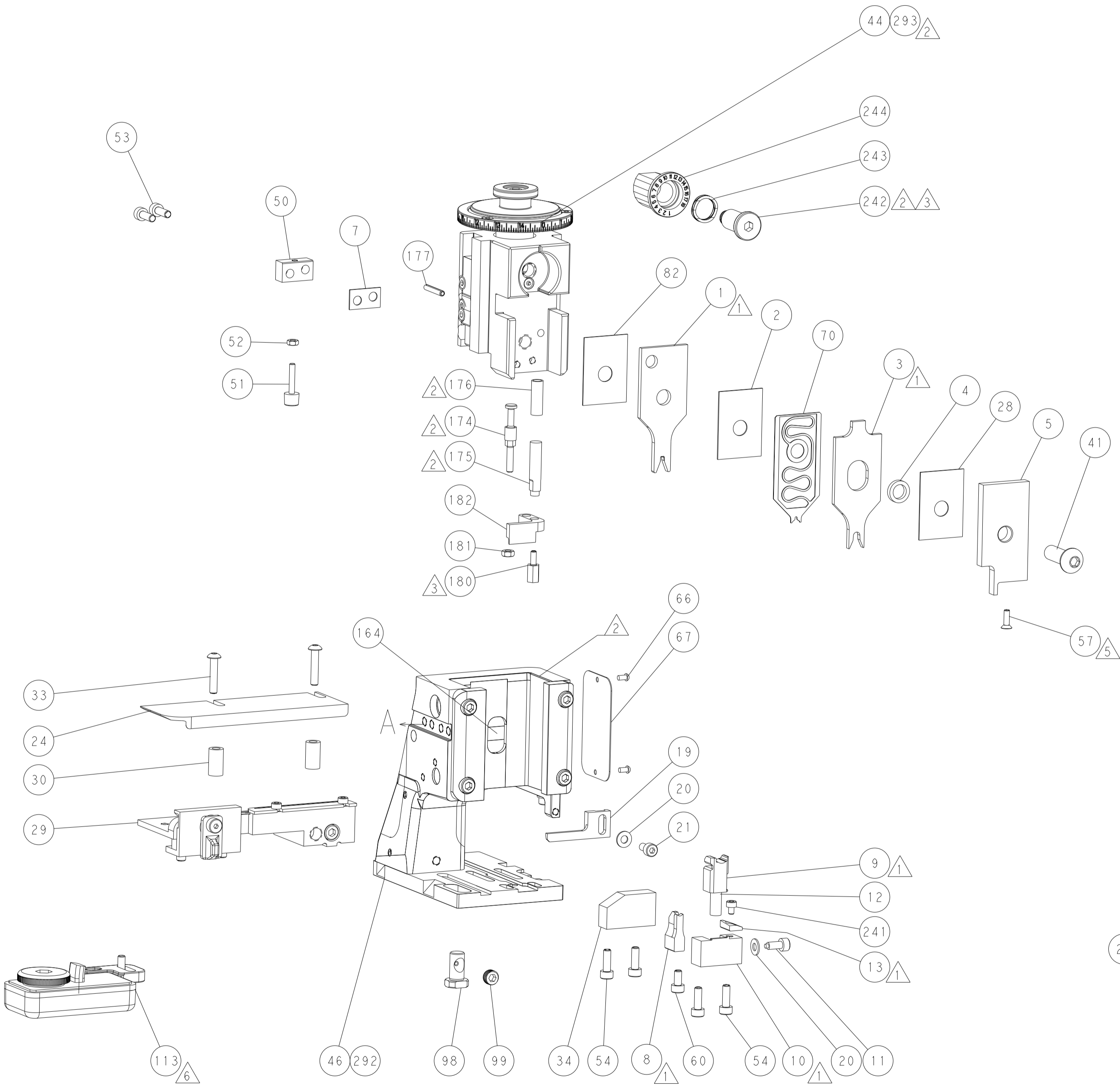
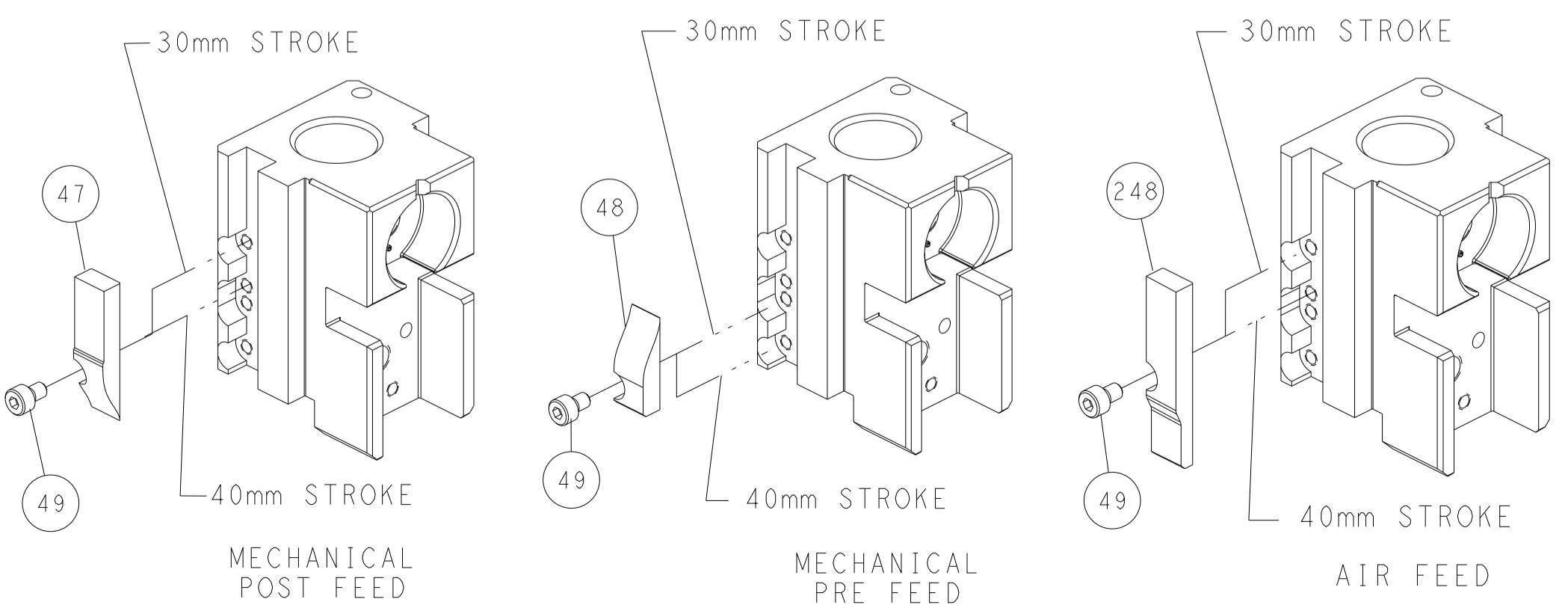

SHEAR DEPRESSOR DETAIL

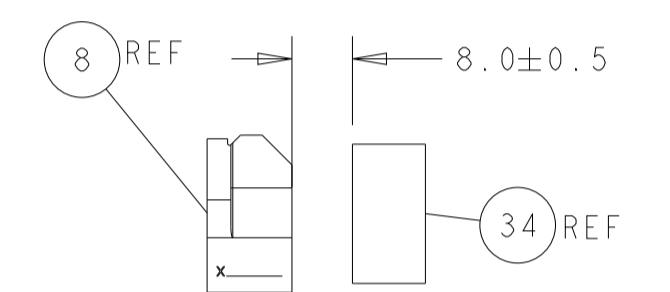

TERMINAL SUPPORT LOCATION

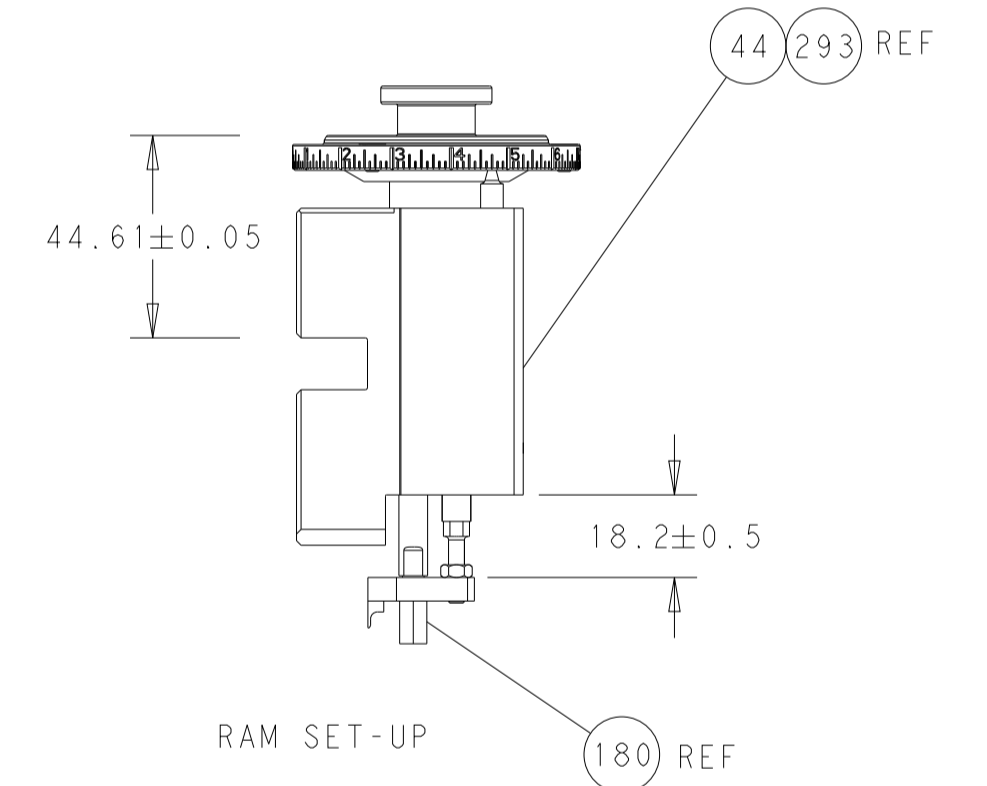

RAM SET-UP

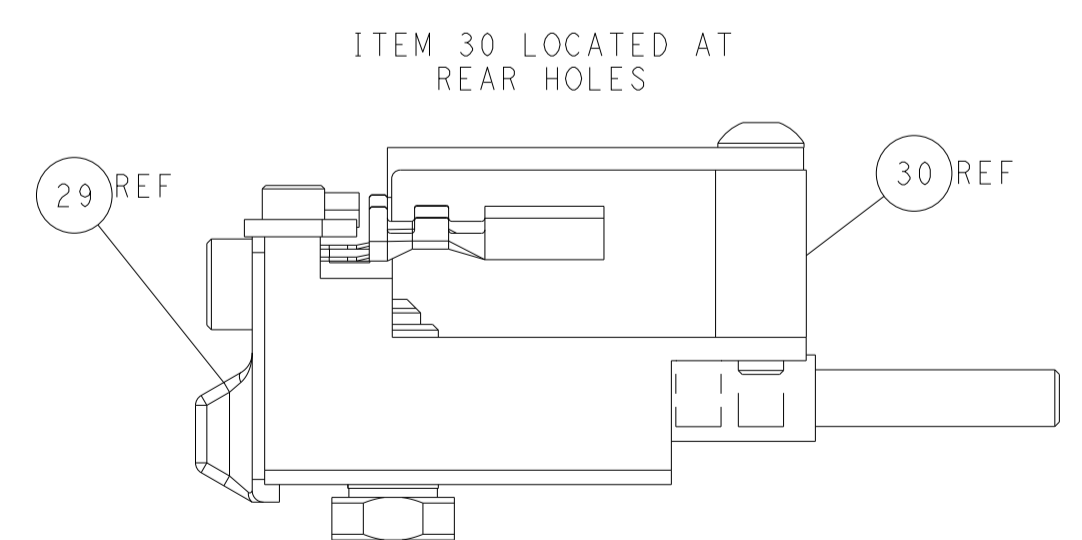

FEED TRACK POSITION GUIDE BY INSULATION BARREL

ATLANTIC VERSION
 Shown on sheets 1 of 4 & 2 of 4
 (Pacific version shown on sheets 3 of 4 & 4 of 4)

DIMENSIONS:		TOLERANCES UNLESS OTHERWISE SPECIFIED:		DWN R. HUANG 13OCT2011		TE Connectivity	
mm	0 PLC ±	1 PLC ±	2 PLC ±	3 PLC ±	4 PLC ±	5 PLC ±	Harrisburg, PA 17105-3608
MATERIAL:	FINISH:	WEIGHT:	SCALE:	APVD: S. XI 13OCT2011	NAME: I. CRUZ 13OCT2011	SIZE: A1	CAGE CODE: 00779
Customer Accessible Production Drawing				DRAWING NO: C=2151139		RESTRICTED TO:	
				SHEET 2 OF 4		REV F1	

PART NUMBER	REVISION	DESCRIPTION	FEED TYPE
2-2151139-1	F	FINE CRIMP HEIGHT ADJUST	MECHANICAL
2-2151139-2	F	FINE CRIMP HEIGHT ADJUST	PNEUMATIC
7-2151139-7	F	CRIMP TOOLING KIT	-

PACIFIC VERSION TERMINATOR
 INTERFACE ADAPTER



APPLICATOR DATA		
CRIMP	SIZE	TYPE
WIRE	2.03 mm [.080]	F
INSUL	4.06 mm [.160]	O
APPLICATOR INSTRUCTIONS 408-35042		

***WARNING**
 ON INSTALLATION, SET WIRE DISC TO CRIMP HEIGHT REFERENCE SETTING FOR LARGEST WIRE SIZE. CRIMP HEIGHT REFERENCE SETTINGS GREATER THAN THE VALUE SHOWN MAY CAUSE DAMAGE TO THE CRIMP TOOLING, REFER TO THE INSTRUCTION SHEET FOR PROPER SETUP AND ADJUSTMENTS.

TERMINAL DATA: TE TERMINAL		TE CRIMP SPECIFICATION	
TERMINAL NAME: DIA 1.5mm PIN or SOCKET CONTACT, SINGLE WIRE			
WIRE STRIP LENGTH		TERMINAL INSULATION DIAMETER RANGE	
4.20-4.80 mm [1.165-.189 IN]		∅ 3.4mm MAX	
TERMINAL APPLICATION SPECIFICATION	(A)114-18040 (B)114-18020	-	-
TERMINALS APPLIED			
TE TERMINAL	TE TERMINAL	TE SEAL	TE SEAL
(A) 929989-1	(B) 929974-9		(A) 828904-1
(A) 929989-4	(B) 1-929974-4		(A) 828904-2
(A) 929989-7	(A) 1-1418497-0		(A) 828904-3
(A) 929989-8	(B) 929967-1		(B) 828920-1
(A) 1-929989-0	(B) 929967-7		(B) 828920-2
(B) 929974-1	(B) 929967-8		
(B) 929974-4	(B) 1-929967-0		
(B) 929974-7	(B) 1-929967-4		
(B) 929974-8			

SEAL INSULATION DIAMETER RANGE
∅ 1.2-2.1 mm

TERMINAL DATA: TE TERMINAL		TE CRIMP SPECIFICATION	
TERMINAL NAME: DIA 1.5mm PIN or SOCKET CONTACT, SINGLE WIRE			
WIRE STRIP LENGTH		TERMINAL INSULATION DIAMETER RANGE	
4.20-4.80 mm [1.165-.189 IN]		∅ 1.2-2.1mm	
TERMINAL APPLICATION SPECIFICATION	(A)114-18040 (B)114-18020	-	-
TERMINALS APPLIED			
TE TERMINAL	TE TERMINAL	TE SEAL	TE SEAL
(A) 1703013-1			(A) 828904-1
(A) 1703013-2			(A) 828904-2
(A) 1703013-4			(A) 828904-3
(A) 1703013-8			(B) 828920-1
(A) 1703049-1			(B) 828920-2

SEAL INSULATION DIAMETER RANGE
∅ 1.2-2.1 mm

WIRE SIZE	CRIMP HEIGHT mm [INCH]	CRIMP HEIGHT REFERENCE SETTING
1.00mm2	1.45 +/- 0.03 [.057 +/- .001]	3.7
0.75mm2	1.36 +/- 0.03 [.054 +/- .001]	4.5
0.50mm2	1.27 +/- 0.03 [.050 +/- .001]	5.5

- RECOMMENDED SPARE PARTS
- REFER TO SUPPLIED INSTRUCTION SHEET FOR CLEANING, LUBRICATION AND STORAGE OF APPLICATOR.
- APPLY PART NUMBER 2-23419-6 LOCTITE TO THREADS OF ITEM 242.
- CRIMP HEIGHT REFERENCE SETTING WAS THE SETTING USED WHEN THE APPLICATOR WAS QUALIFIED AT THE FACTORY. ADJUSTMENT MAY BE NECESSARY WHEN RUNNING APPLICATOR IN THE FIELD.
- APPLY TORQ-SEAL IN ALLEN SOCKET TO FILL HOLE AFTER FLAT HD HAS BEEN ADJUSTED TO CORRECT HEIGHT AT QUALIFICATION. APPLY #1-23419-5 LOC-TITE TO THREADS.
- TERMINAL LUBRICANT IS RECOMMENDED.
- 7. UNLESS SPECIFIED OTHERWISE TORQUE VALUES SHALL BE USED PER DOCUMENT, 101-35000.
- THIS CRIMP PARAMETER IS PROVIDED TO MEET A CUSTOM AND UNIQUE CUSTOMER REQUIREMENT. IT HAS BEEN EVALUATED AND IS CONDITIONALLY SPECIFIED BY TE CONNECTIVITY. THIS CUSTOMIZED CRIMP PARAMETER IS NOT LISTED AS AN APPROVED APPLICATION WITHIN A TE CONNECTIVITY APPLICATION SPECIFICATION. **TE CONNECTIVITY EXPRESSLY DISCLAIMS ANY AND ALL WARRANTIES THAT THE PRODUCT WILL PERFORM SIMILARLY TO VALIDATED AND APPROVED APPLICATIONS, AS STATED WITHIN TE CONNECTIVITY APPLICATION SPECIFICATIONS, INCLUDING BUT NOT LIMITED TO IMPLIED WARRANTIES OF MERCHANTABILITY OR FITNESS FOR PARTICULAR PURPOSE.** AS SUCH, IT IS HIGHLY RECOMMENDED THAT THE CUSTOMER PERFORM FURTHER DETAILED EVALUATION TO ASSESS PRODUCT PERFORMANCE IN THE SPECIFIC APPLICATION.

TERMINAL DATA: TE TERMINAL		TE CRIMP SPECIFICATION	
TERMINAL NAME: DIA 1.5mm PIN or SOCKET CONTACT, SINGLE WIRE			
WIRE STRIP LENGTH		TERMINAL INSULATION DIAMETER RANGE	
4.20-4.80mm [1.165-.189 IN]		∅ 3.4mm MAX	
TERMINAL APPLICATION SPECIFICATION	(B)114-18020	-	-
TERMINALS APPLIED			
TE TERMINAL	TE TERMINAL	TE SEAL	TE SEAL
(B) 929974-1	(B) 929974-8		(B) 828920-1
(B) 929974-4	(B) 929974-9		(B) 828920-2
(B) 929974-7	(B) 1-929974-4		

SEAL INSULATION DIAMETER RANGE
∅ 1.2-2.1mm

WIRE SIZE	CRIMP HEIGHT mm [INCH]	CRIMP HEIGHT REFERENCE SETTING
18 AWG	1.29 +/- 0.05 [.051 +/- .002]	5.3

LOC	DIST	REVISIONS					
A	66	P	LYN	DESCRIPTION	DATE	DWN	APVD
		-		SEE SHEET 1			

-	1	1	2119082-9	CAM, SNAIL, INSULATION ADJUSTMENT	244
-	1	1	2079764-1	WASHER, WAVE SPRING, CREST-TO-CREST	243
-	1	1	2119083-1	RETAINER, INSULATION DIAL	242
-	1	1	7-18023-7	SCR, SKT HD CAP M3 X 4.0	241
-	-	1	2119580-1	MECHANICAL FEED ASSEMBLY	239
-	1	-	2844940-1	AIR FEED MODULE	238
-	REF	REF	994970-2	COUNTER, MAGNETIC	164
-	1	-	2119641-2	FEED CAM, AIR FEED	151
-	1	1	2168083-8	SCR, SKT HD CAP, RoHS, M4 X 16	144
-	4	4	2168083-9	SCR, SKT HD CAP, RoHS, M4 X 20	143
-	-	1	2119653-2	FEED CAM, POST FEED	142
-	1	1	1-1803583-0	APPLICATOR BASIC ASSEMBLY, SF	141
-	1	1	1803516-1	RAM ASSEMBLY, SF PACIFIC	140
-	1	1	2119955-1	ASSY, LUBRICATOR, SIDE FEED	113
-	1	1	2844908-1	SCREW, LOCKING	99
-	1	1	2844907-1	POST, LOCKING	98
-	1	1	455888-5	SPACER, CRIMPER	82
-	1	1	1803607-3	DOCUMENTATION PACKAGE	71
-	1	1	1803948-6	DEPRESSOR, WIRE, SPECIAL	70
-	1	1	2119740-1	TAG, IDENTIFICATION	67
-	2	2	2168078-1	SCREW, DRIVE, RH, RoHS, 2 x .188	66
-	1	1	5-18022-5	SCR, HEX HD CAP, M4 X 6.0	59
-	1	1	985575-3	SCR, FLT SKT HD CAP M3 X 10.0	57
-	1	1	1338685-1	PAWL, FEED	56
-	2	2	2168083-3	SCR, SKT HD CAP, RoHS, M4 X 12.0	53
-	1	1	5018030-1	NUT, HEX, REG, RoHS, M3	52
-	1	1	811242-5	BUMPER, HOLD DOWN	51
-	1	1	690753-2	SPACER, TONKER	50
-	1	2	18023-9	SCR, SKT HD CAP M4 X 6.0	49
-	-	1	2119652-1	FEED CAM, PRE FEED	48
-	1	1	1803602-1	SCR, BHSC, RoHS (M8 X 25)	41
-	1	1	1-1752356-7	SUPPORT, TERMINAL	34
-	2	2	2079383-5	SCR, BHSC, RoHS (M4 X 20)	33
-	2	2	2-2844962-8	SPACER, CYLINDRICAL, STRIP GUIDE	30
-	1	1	2844992-1	ASSEMBLY, STRIP GUIDE	29
-	1	1	455888-5	SPACER, CRIMPER	28
-	1	1	1320928-6	STRIP GUIDE	24
-	1	1	2168083-2	SCR, SKT HD CAP, RoHS, M4 X 8.0	21
-	2	2	1-18028-2	WASHER, FLAT, REG M4	20
-	1	1	2119533-1	STRIPPER, SIDE FEED	19
-	1	1	2119806-1	INSERT, SHEAR	13
-	1	1	3-22280-3	SPRING, COMPRESSION	12
-	1	1	1-356885-4	STOP, SHEAR	11
-	1	1	2119805-1	SHEAR HOLDER, FRONT	10
-	1	1	318707-1	FLOATING SHEAR, FRONT	9
-	1	1	1338693-1	ANVIL, COMBINATION .080	8
-	1	1	3-240641-8	SPACER	7
-	1	1	2119781-1	DEPRESSOR, SHEAR	5
-	1	1	3-238011-3	BLOCK, CRIMPER SPACER	4
-	1	1	2-1803019-4	CRIMPER, INSULATION O	3
-	1	1	455888-6	SPACER, CRIMPER	2
-	1	1	1633730-5	CRIMPER, WIRE	1

PACIFIC VERSION
 Shown on sheets 3 of 4 & 4 of 4
 (Atlantic version shown on sheets 1 of 4 & 2 of 4)

DIMENSIONS:		TOLERANCES UNLESS OTHERWISE SPECIFIED:		MATERIAL:	
mm	0 PLC ±	1 PLC ±	2 PLC ±	3 PLC ±	4 PLC ±
	ANGLES ±	FINISH			

ITEM NO	PART NO	DESCRIPTION	
-77	-22	-21	TE Connectivity Harrisburg, PA 17105-3608

NAME	SIZE	CAGE CODE	DRAWING NO	RESTRICTED TO
Ocean Side Feed Applicator	A1	00779	2151139	

Customer Accessible Production Drawing SCALE 1:2 SHEET 3 OF 4 REV F1

LOC	DIST	REVISIONS					
		P	LTN	DESCRIPTION	DATE	DWN	APVD
A	66	-	-	SEE SHEET 1	-	-	-

FEED TYPE MECHANICAL

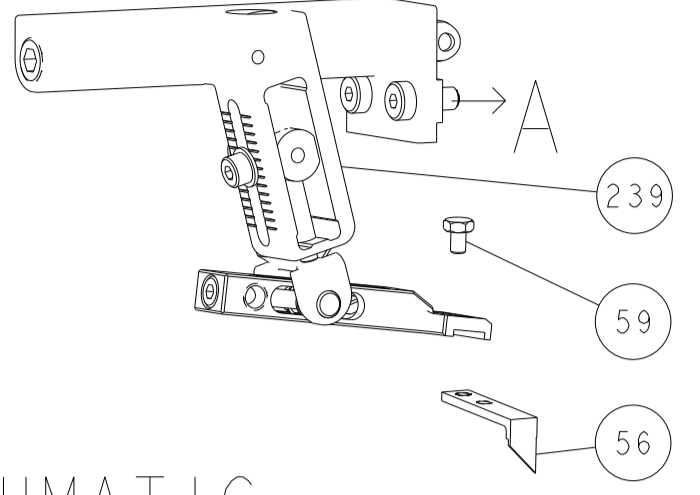

PNEUMATIC

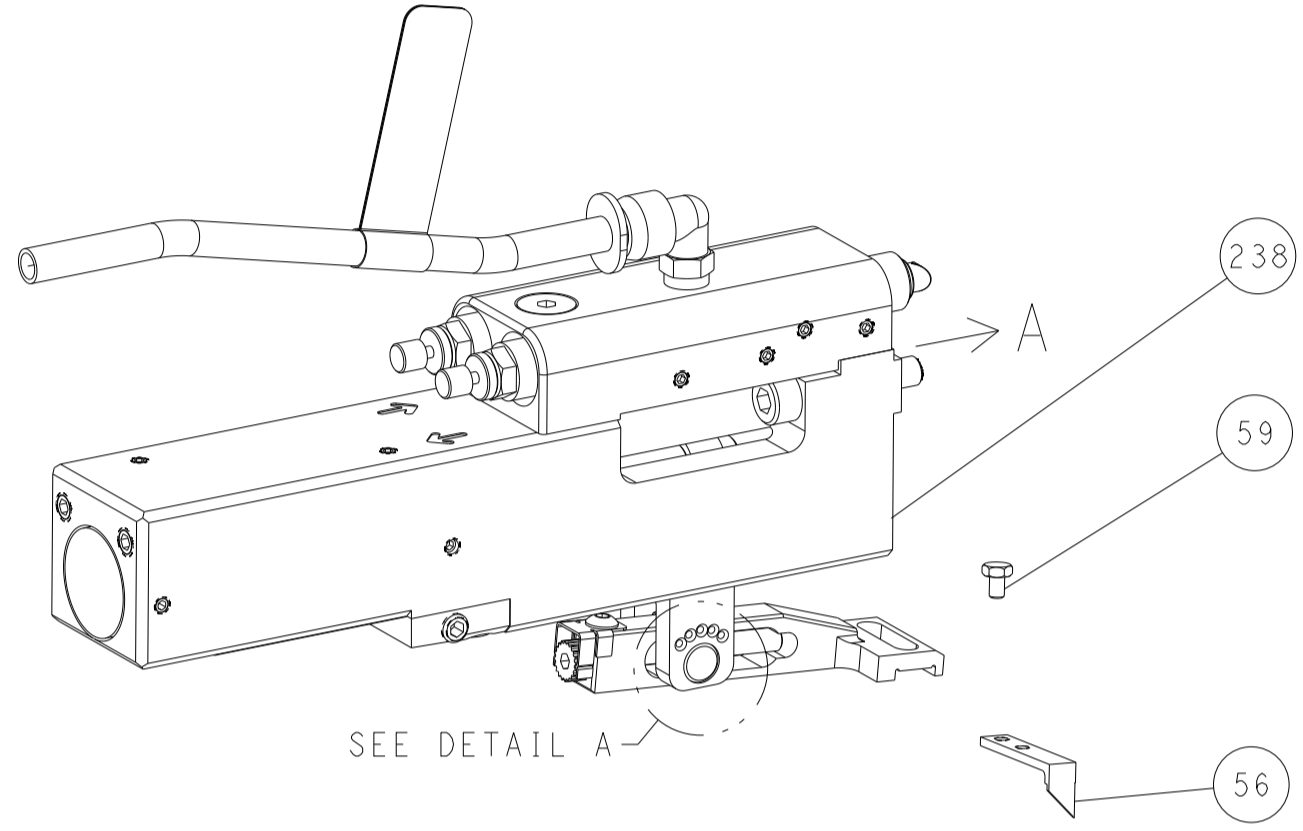

FEED SPRING SETTING POSITION (SHOWN FROM REAR SIDE)

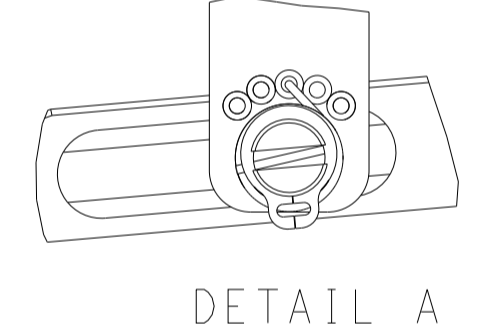

CAM POSITIONS

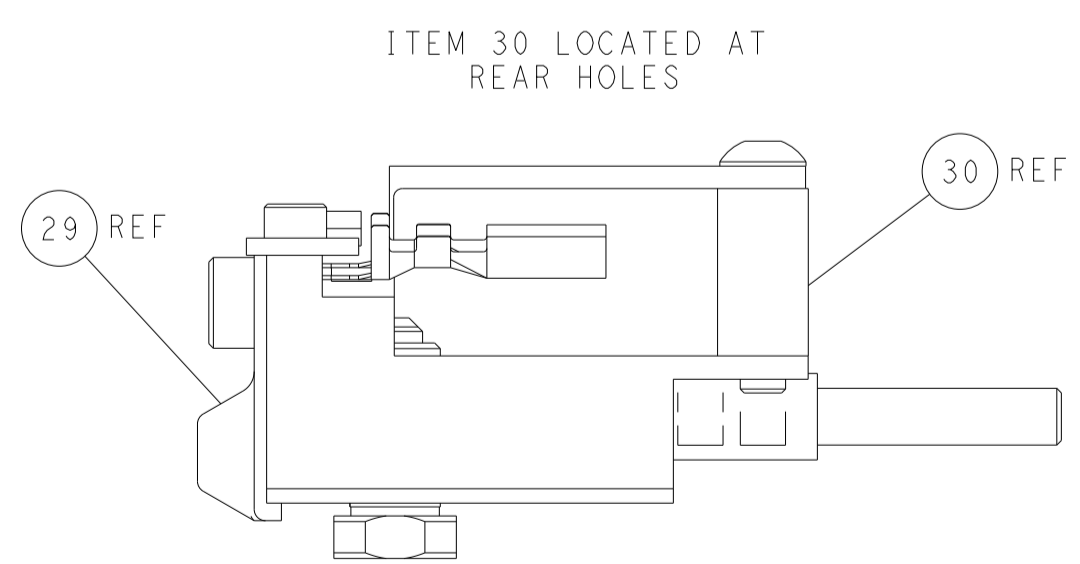
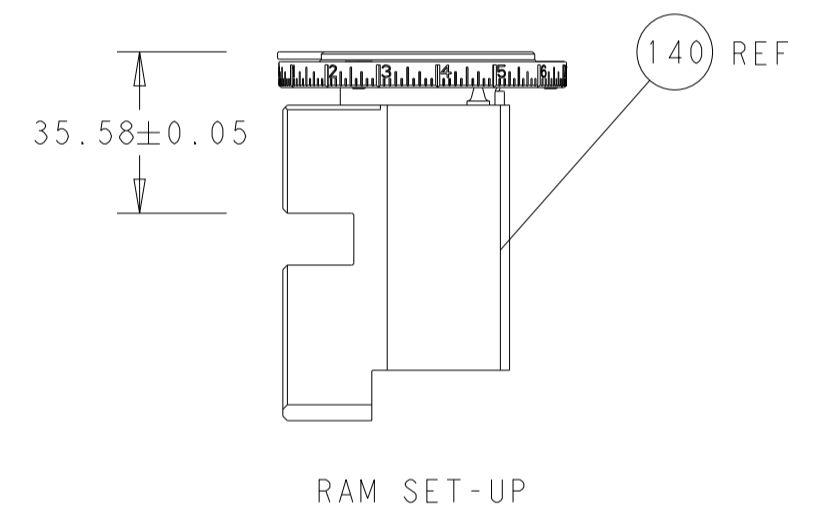
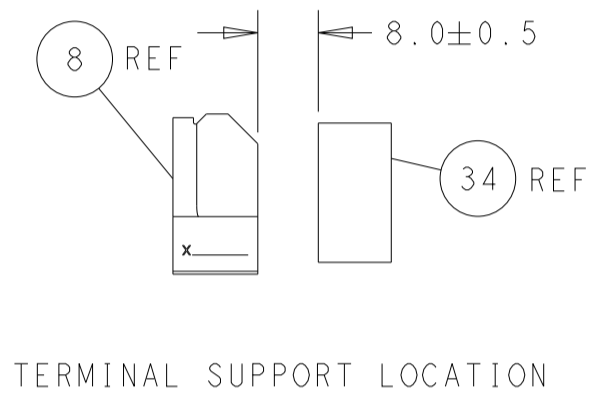
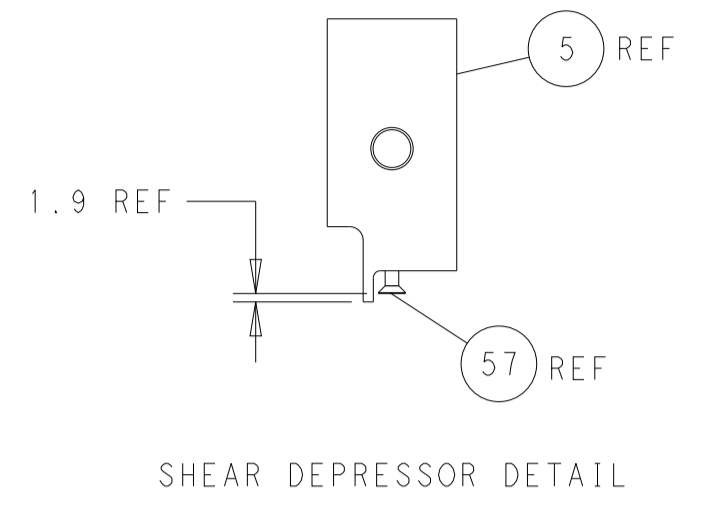
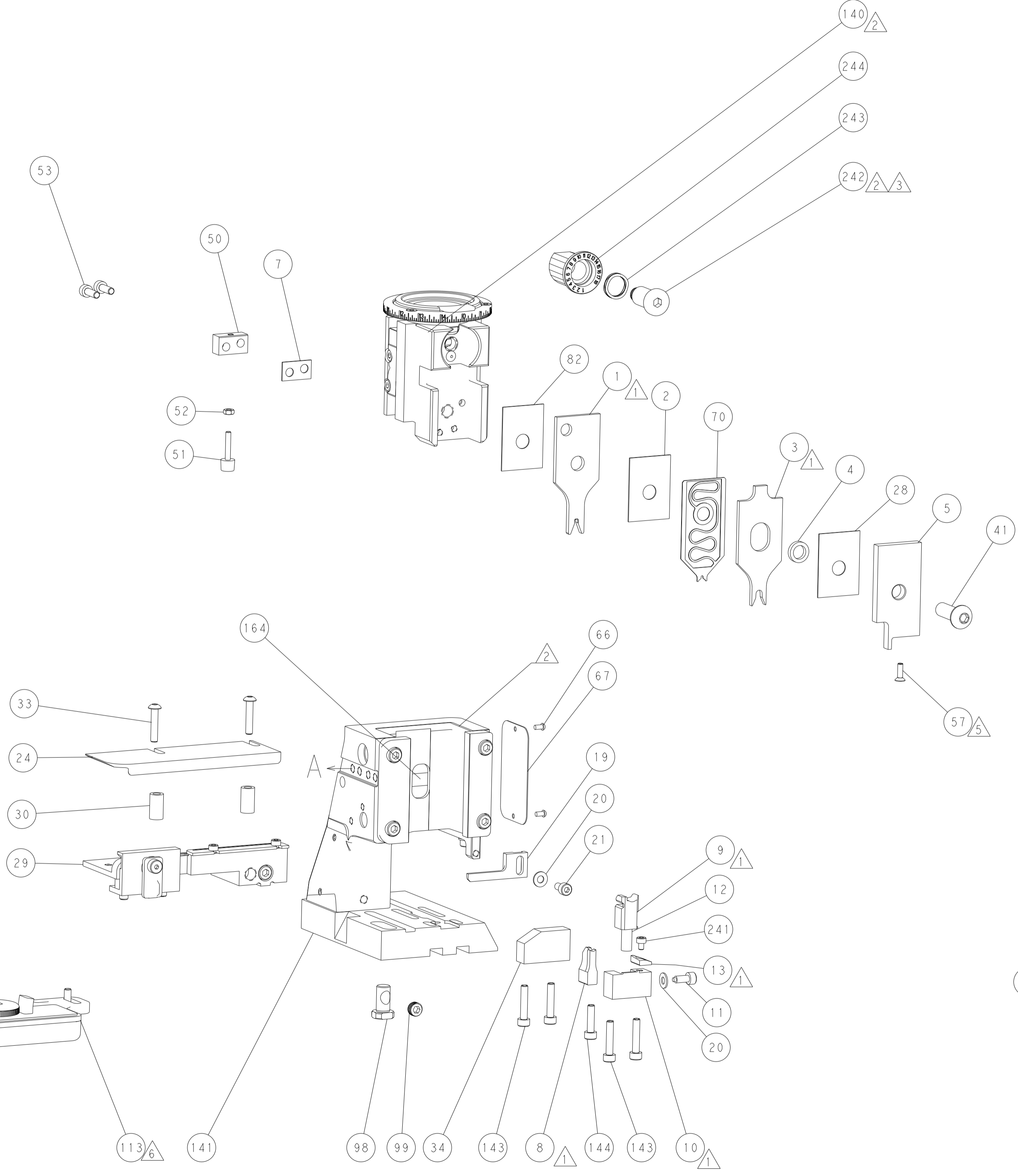
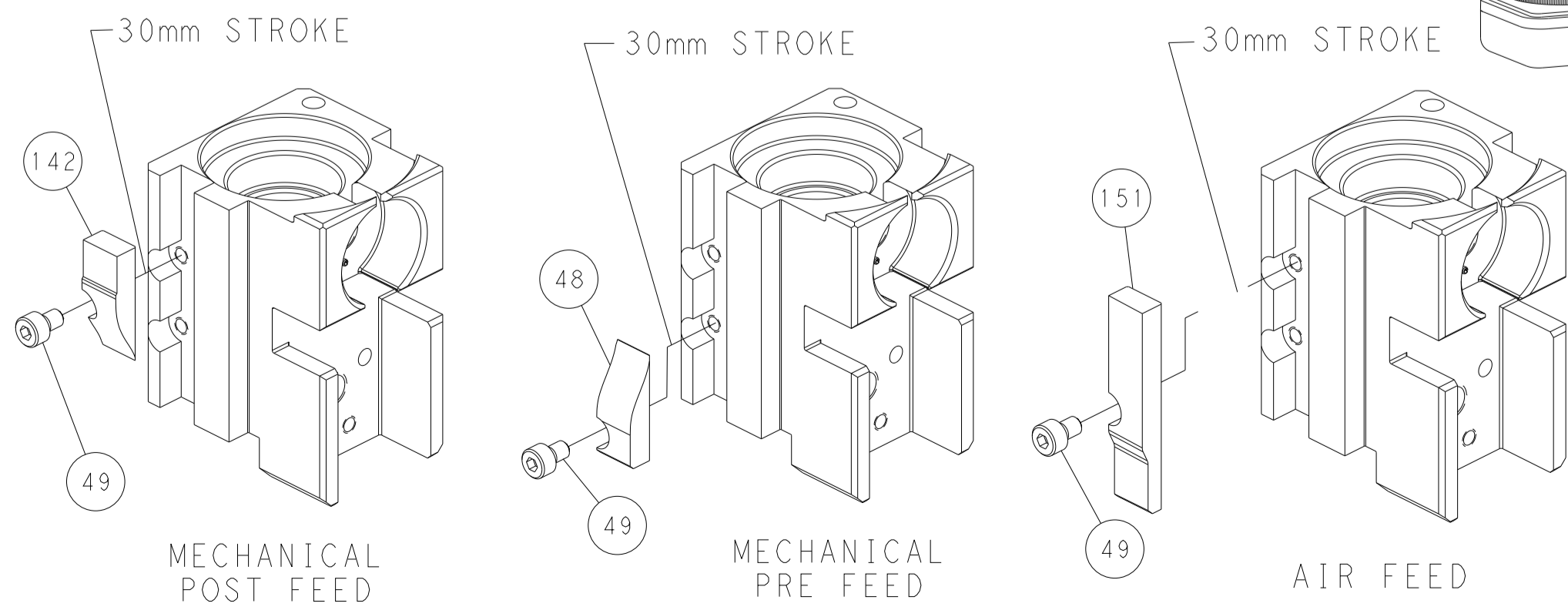

PACIFIC VERSION
 Shown on sheets 3 of 4 & 4 of 4
 (Atlantic version shown on sheets 1 of 4 & 2 of 4)

<small>THIS DRAWING IS UNPUBLISHED. RELEASED FOR PUBLICATION. ALL RIGHTS RESERVED. © 2011 BY TYCO ELECTRONICS CORPORATION. THIS DRAWING IS UNPUBLISHED. RELEASED FOR PUBLICATION. ALL RIGHTS RESERVED. © 2011 BY TYCO ELECTRONICS CORPORATION. THIS DRAWING IS UNPUBLISHED. RELEASED FOR PUBLICATION. ALL RIGHTS RESERVED. © 2011 BY TYCO ELECTRONICS CORPORATION.</small>		DWN: H. HUANG 13OCT2011 CHK: S. XI 13OCT2011 APVD: J. CRUZ 13OCT2011	NAME: TE Connectivity Harrisburg, PA 17105-3608
DIMENSIONS: mm TOLERANCES UNLESS OTHERWISE SPECIFIED: 0 PLC ± 1 PLC ± 2 PLC ± 3 PLC ± 4 PLC ± ANGLES FINISH ±	APPLICATION SPEC: - PRODUCT SPEC: - WEIGHT: - SCALE: 1:2	SIZE: A1 CAGE CODE: 00779 DRAWING NO: C=2151139	RESTRICTED TO: - SHEET 4 OF 4 REV F1