

High-Output Drive Rail-to-Rail Op Amp

Features

- Small Footprint SOT-23-5 and Power MSOP-8 Packages
- >80 mA Peak Output Sink and Source with 5V Supply
- Drives Large Capacitive Loads (6000 pF with 10V Supply)
- Guaranteed 2.2V, 3V, 5V, and 10V Performance
- 500 kHz Gain-Bandwidth Product
- 0.01% Total Harmonic Distortion at 1 kHz (10V, 2 k Ω)
- 1 mA Typical Power Supply Current at 5V

Applications

- Battery-Powered Instrumentation
- PCMCIA, USB Peripherals
- Portable Computers and PDAs

General Description

The MIC7300 is a high-performance CMOS operational amplifier featuring rail-to-rail input and output with strong output drive capability. It is able to source and sink in excess of 80 mA into large capacitive loads.

The input common-mode range extends beyond the rails by 300 mV, and the output voltage typically swings to within 150 μ V of both rails when driving a 100 k Ω load.

The amplifier operates from 2.2V to 10V and is fully specified at 2.2V, 3V, 5V, and 10V. Gain bandwidth and slew rate are 500 kHz and 0.5 V/ μ s, respectively.

The MIC7300 is available in the IttyBitty SOT-23-5 package for space-conscious circuits and in high-power MM8 8-lead MSOP for improved heat dissipation in higher power applications.

Package Types

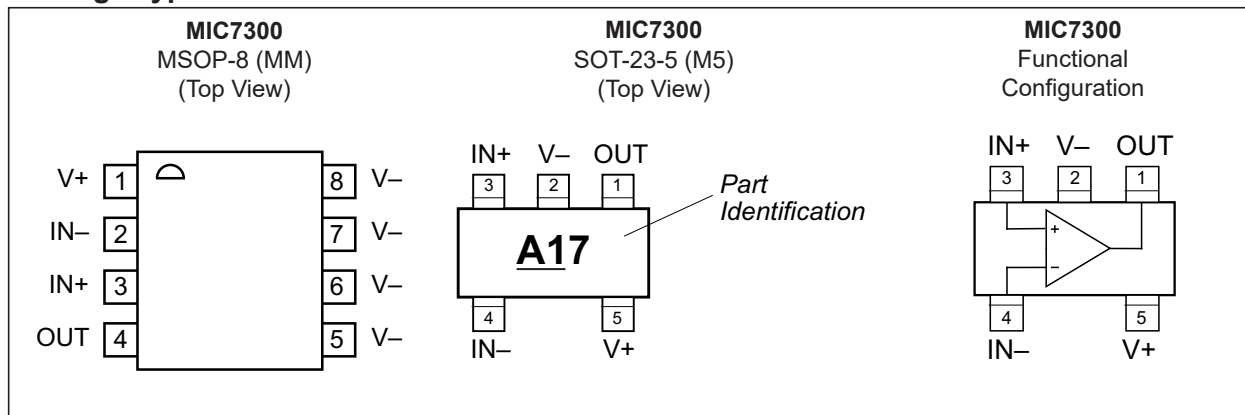

MIC7300

1.0 ELECTRICAL CHARACTERISTICS

Absolute Maximum Ratings †

Supply Voltage, ($V_{V+} - V_{V-}$)	12V
Differential Input Voltage ($V_{IN+} - V_{IN-}$)	$\pm 12V$
I/O Pin Voltage, (V_{IN}, V_{OUT}) (Note 1)	$V_{V+} + 0.3V$ to $V_{V-} - 0.3V$
ESD Protection On All Pins	Note 2

Operating Ratings ††

Supply Voltage, ($V_{V+} - V_{V-}$)	2.2V to 10V
---------------------------------------	-------------

† Notice: Exceeding the absolute maximum rating may damage the device.

†† Notice: The device is not guaranteed to function outside its operating rating.

Note 1: I/O Pin Voltage is any external voltage to which an input or output is referenced.

2: Devices are ESD protected; however, handling precautions are recommended.

DC CHARACTERISTICS (2.2V)

Electrical Characteristics: Unless otherwise indicated, $V_{V+} = +2.2V$, $V_{V-} = 0V$, $V_{CM} = V_{OUT} = V_{V+}/2$; $R_L = 1\text{ M}\Omega$; $T_J = 25^\circ\text{C}$.

Parameter	Symbol	Min.	Typ.	Max.	Units	Conditions
Input Offset Voltage	V_{OS}	—	1.0	9	mV	—
Input Offset Voltage Average Drift	TCV_{OS}	—	1.0	—	$\mu\text{V}/^\circ\text{C}$	—
Input Bias Current	I_B	—	0.5	—	pA	—
Input Offset Current	I_{OS}	—	0.25	—	pA	—
Input Resistance	R_{IN}	—	>1	—	$\text{T}\Omega$	—
Common-Mode Rejection Ratio	CMRR	45	65	—	dB	$0V \leq V_{CM} \leq 2.2V$, (Note 1)
Input Common-Mode Voltage	V_{CM}	—	-0.3	0.0	V	Input low, CMRR ≥ 45 dB
		2.2	2.5	—	V	Input high, CMRR ≥ 45 dB
Power Supply Rejection Ratio	PSRR	55	75	—	dB	$V_{V+} = V_{V-} = 1.1V$ to $2.5V$, $V_{CM} = 0$
Common-Mode Input Capacitance	C_{IN}	—	3	—	pF	—

Note 1: CMRR is determined as follows: The maximum ΔV_{OS} over the V_{CM} range is divided by the magnitude of the V_{CM} range. The measurement points are: V_{V-} , $(V_{V+} - V_{V-})/2$, and V_{V+} .

2: Continuous short circuit may exceed absolute maximum T_J under some conditions.

DC CHARACTERISTICS (2.2V) (CONTINUED)

Electrical Characteristics: Unless otherwise indicated, $V_{V+} = +2.2V$, $V_{V-} = 0V$, $V_{CM} = V_{OUT} = V_{V+}/2$; $R_L = 1\text{ M}\Omega$; $T_J = 25^\circ\text{C}$.

Parameter	Symbol	Min.	Typ.	Max.	Units	Conditions
Output Swing	V_{OUT}	—	0.15	1	mV	Output high, $R_L = 100\text{ k}\Omega$, specified as $V_{V+} - V_{OUT}$
		—	—	1	mV	Output high, $R_L = 100\text{ k}\Omega$, specified as $V_{V+} - V_{OUT}$, $-40^\circ\text{C} \leq T_J \leq +85^\circ\text{C}$
		—	0.15	1	mV	Output low, $R_L = 100\text{ k}\Omega$
		—	—	1	mV	Output low, $R_L = 100\text{ k}\Omega$, $-40^\circ\text{C} \leq T_J \leq +85^\circ\text{C}$
		—	10	33	mV	Output high, $R_L = 2\text{ k}\Omega$, specified as $V_{V+} - V_{OUT}$
		—	—	50	mV	Output high, $R_L = 2\text{ k}\Omega$, specified as $V_{V+} - V_{OUT}$, $-40^\circ\text{C} \leq T_J \leq +85^\circ\text{C}$
		—	10	33	mV	Output low, $R_L = 2\text{ k}\Omega$
		—	—	50	mV	Output low, $R_L = 2\text{ k}\Omega$, $-40^\circ\text{C} \leq T_J \leq +85^\circ\text{C}$
		—	33	110	mV	Output high, $R_L = 600\Omega$, specified as $V_{V+} - V_{OUT}$
		—	—	165	mV	Output high, $R_L = 600\Omega$, specified as $V_{V+} - V_{OUT}$, $-40^\circ\text{C} \leq T_J \leq +85^\circ\text{C}$
		—	33	110	mV	Output low, $R_L = 600\Omega$
		—	—	165	mV	Output low, $R_L = 600\Omega$, $-40^\circ\text{C} \leq T_J \leq +85^\circ\text{C}$
Output Short Circuit Current	I_{SC}	20	40	—	mA	Sinking or sourcing (Note 2)
Supply Current	I_S	—	0.7	2.0	mA	$V_{OUT} = V+/2$

Note 1: CMRR is determined as follows: The maximum ΔV_{OS} over the V_{CM} range is divided by the magnitude of the V_{CM} range. The measurement points are: V_{V-} , $(V_{V+} - V_{V-})/2$, and V_{V+} .

2: Continuous short circuit may exceed absolute maximum T_J under some conditions.

AC CHARACTERISTICS (2.2V)

Electrical Characteristics: Unless otherwise indicated, $V_{V+} = +2.2V$, $V_{V-} = 0V$, $V_{CM} = V_{OUT} = V_{V+}/2$; $R_L = 1\text{ M}\Omega$; $T_J = 25^\circ\text{C}$, Note 1.

Parameter	Symbol	Min.	Typ.	Max.	Units	Conditions
Slew Rate	SR	—	0.5	—	V/ μs	—
Gain-Bandwidth Product	GBWP	—	0.55	—	MHz	—
Phase Margin	ϕ_m	—	80	—	$^\circ$	$C_L = 0\text{ pF}$
		—	40	—	$^\circ$	$C_L = 2500\text{ pF}$
Gain Margin	G_m	—	10	—	dB	—

Note 1: All limits guaranteed by testing or statistical analysis.

MIC7300

DC CHARACTERISTICS (3.0V)

Electrical Characteristics: Unless otherwise indicated, $V_{V+} = +3.0V$, $V_{V-} = 0V$, $V_{CM} = V_{OUT} = V_{V+}/2$; $R_L = 1\text{ M}\Omega$; $T_J = 25^\circ\text{C}$.

Parameter	Symbol	Min.	Typ.	Max.	Units	Conditions
Input Offset Voltage	V_{OS}	—	1.0	9	mV	—
Input Offset Voltage Average Drift	TCV_{OS}	—	1.0	—	$\mu\text{V}/^\circ\text{C}$	—
Input Bias Current	I_B	—	0.5	—	pA	—
Input Offset Current	I_{OS}	—	0.25	—	pA	—
Input Resistance	R_{IN}	—	>1	—	T Ω	—
Common-Mode Rejection Ratio	CMRR	50	70	—	dB	$0V \leq V_{CM} \leq 3.0V$, (Note 1)
Input Common-Mode Voltage	V_{CM}	—	-0.3	0.0	V	Input low, CMRR ≥ 50 dB
		3.0	3.3	—	V	Input high, CMRR ≥ 50 dB
Power Supply Rejection Ratio	PSRR	55	75	—	dB	$V_{V+} = V_{V-} = 1.5V$ to $5.0V$, $V_{CM} = 0$
Common-Mode Input Capacitance	C_{IN}	—	3	—	pF	—
Output Swing	V_{OUT}	—	0.2	1	mV	Output high, $R_L = 100\text{ k}\Omega$, specified as $V_{V+} - V_{OUT}$
		—	—	1	mV	Output high, $R_L = 100\text{ k}\Omega$, specified as $V_{V+} - V_{OUT}$, $-40^\circ\text{C} \leq T_J \leq +85^\circ\text{C}$
		—	0.2	1	mV	Output low, $R_L = 100\text{ k}\Omega$
		—	—	1	mV	Output low, $R_L = 100\text{ k}\Omega$, $-40^\circ\text{C} \leq T_J \leq +85^\circ\text{C}$
		—	10	33	mV	Output high, $R_L = 2\text{ k}\Omega$, specified as $V_{V+} - V_{OUT}$
		—	—	50	mV	Output high, $R_L = 2\text{ k}\Omega$, specified as $V_{V+} - V_{OUT}$, $-40^\circ\text{C} \leq T_J \leq +85^\circ\text{C}$
		—	10	33	mV	Output low, $R_L = 2\text{ k}\Omega$
		—	—	50	mV	Output low, $R_L = 2\text{ k}\Omega$, $-40^\circ\text{C} \leq T_J \leq +85^\circ\text{C}$
		—	33	110	mV	Output high, $R_L = 600\Omega$, specified as $V_{V+} - V_{OUT}$
		—	—	165	mV	Output high, $R_L = 600\Omega$, specified as $V_{V+} - V_{OUT}$, $-40^\circ\text{C} \leq T_J \leq +85^\circ\text{C}$
		—	33	110	mV	Output low, $R_L = 600\Omega$
		—	—	165	mV	Output low, $R_L = 600\Omega$, $-40^\circ\text{C} \leq T_J \leq +85^\circ\text{C}$

Note 1: CMRR is determined as follows: The maximum ΔV_{OS} over the V_{CM} range is divided by the magnitude of the V_{CM} range. The measurement points are: V_{V-} , $(V_{V+} - V_{V-})/2$, and V_{V+} .

2: Continuous short circuit may exceed absolute maximum T_J under some conditions.

DC CHARACTERISTICS (3.0V) (CONTINUED)

Electrical Characteristics: Unless otherwise indicated, $V_{V+} = +3.0V$, $V_{V-} = 0V$, $V_{CM} = V_{OUT} = V_{V+}/2$; $R_L = 1\text{ M}\Omega$; $T_J = 25^\circ\text{C}$.

Parameter	Symbol	Min.	Typ.	Max.	Units	Conditions
Output Short Circuit Current	I_{SC}	60	95	—	mA	Sinking or sourcing (Note 2)
Supply Current	I_S	—	0.8	2.2	mA	—

Note 1: CMRR is determined as follows: The maximum ΔV_{OS} over the V_{CM} range is divided by the magnitude of the V_{CM} range. The measurement points are: V_{V-} , $(V_{V+} - V_{V-})/2$, and V_{V+} .

2: Continuous short circuit may exceed absolute maximum T_J under some conditions.

AC CHARACTERISTICS (3.0V)

Electrical Characteristics: Unless otherwise indicated, $V_{V+} = +3.0V$, $V_{V-} = 0V$, $V_{CM} = 1.5V$, $V_{OUT} = V_{V+}/2$; $R_L = 1\text{ M}\Omega$; $T_J = 25^\circ\text{C}$. Note 1

Parameter	Symbol	Min.	Typ.	Max.	Units	Conditions
Slew Rate	SR	—	0.5	—	V/ μs	—
Gain-Bandwidth Product	GBWP	—	0.45	—	MHz	—
Phase Margin	ϕ_m	—	85	—	$^\circ$	$C_L = 0\text{ pF}$
		—	40	—	$^\circ$	$C_L = 3500\text{ pF}$
Gain Margin	G_m	—	10	—	dB	—

Note 1: All limits guaranteed by testing or statistical analysis.

DC ELECTRICAL CHARACTERISTICS (5.0V)

Electrical Characteristics: Unless otherwise indicated, $V_{V+} = +5.0V$, $V_{V-} = 0V$, $V_{CM} = 1.5V$, $V_{OUT} = V_{V+}/2$; $R_L = 1\text{ M}\Omega$; $T_J = 25^\circ\text{C}$.

Parameters	Sym.	Min.	Typ.	Max.	Units	Conditions
Input Offset Voltage	V_{OS}	—	1.0	9	mV	—
Input Offset Voltage Average Drift	TCV_{OS}	—	1.0	—	$\mu\text{V}/^\circ\text{C}$	—
Input Bias Current	I_B	—	0.5	—	pA	—
Input Offset Current	I_{OS}	—	0.25	—	pA	—
Input Resistance	R_{IN}	—	>1	—	T Ω	—
Common-Mode Rejection Ratio	CMRR	55	80	—	dB	$0V \leq V_{CM} \leq 5V$, Note 1
Input Common-Mode Voltage	V_{CM}	—	-0.3	-0.0	V	Input low, CMRR $\geq 55\text{ dB}$
		5.0	5.3	—	V	Input high, CMRR $\geq 55\text{ dB}$
Power Supply Rejection Ratio	$\pm\text{PSRR}$	55	75	—	dB	$V_{V+} = V_{V-} = 2.5V\text{ to }5.0V$, $V_{CM} = 0$
Common-Mode Input Capacitance	C_{IN}	—	3	—	pF	—

MIC7300

DC ELECTRICAL CHARACTERISTICS (5.0V) (CONTINUED)

Electrical Characteristics: Unless otherwise indicated, $V_{V+} = +5.0V$, $V_{V-} = 0V$, $V_{CM} = 1.5V$, $V_{OUT} = V_{V+}/2$; $R_L = 1\text{ M}\Omega$; $T_J = 25^\circ\text{C}$.

Parameters	Sym.	Min.	Typ.	Max.	Units	Conditions
Output Swing	V_{OUT}	—	0.3	1.0	mV	Output high, $R_L = 100\text{ k}\Omega$, specified as $V_{V+} - V_{OUT}$
		—	—	1.5	mV	Output high, $R_L = 100\text{ k}\Omega$, specified as $V_{V+} - V_{OUT}$, $-40^\circ\text{C} \leq T_J \leq +85^\circ\text{C}$
		—	0.3	1.0	mV	Output low, $R_L = 100\text{ k}\Omega$
		—	—	1.5	mV	Output low, $R_L = 100\text{ k}\Omega$, $-40^\circ\text{C} \leq T_J \leq +85^\circ\text{C}$
		—	15	50	mV	Output high, $R_L = 2\text{ k}\Omega$, specified as $V_{V+} - V_{OUT}$
		—	—	75	mV	Output high, $R_L = 2\text{ k}\Omega$, specified as $V_{V+} - V_{OUT}$, $-40^\circ\text{C} \leq T_J \leq +85^\circ\text{C}$
		—	15	50	mV	Output low, $R_L = 2\text{ k}\Omega$
		—	—	75	mV	Output low, $R_L = 2\text{ k}\Omega$, $-40^\circ\text{C} \leq T_J \leq +85^\circ\text{C}$
		—	50	165	mV	Output high, $R_L = 600\Omega$, specified as $V_{V+} - V_{OUT}$
		—	—	250	mV	Output high, $R_L = 600\Omega$, specified as $V_{V+} - V_{OUT}$, $-40^\circ\text{C} \leq T_J \leq +85^\circ\text{C}$
		—	50	165	mV	Output low, $R_L = 600\Omega$
		—	—	250	mV	Output low, $R_L = 600\Omega$, $-40^\circ\text{C} \leq T_J \leq +85^\circ\text{C}$
Output Short Circuit Current	I_{SC}	85	105	—	mA	Sinking or sourcing (Note 2)
Supply Current	I_S	—	1.0	2.8	mA	$V_{OUT} = V+ / 2$

Note 1: CMRR is determined as follows: The maximum ΔV_{OS} over the V_{CM} range is divided by the magnitude of the VCM range. The measurement points are: V_{V-} , $(V_{V+} - V_{V-})/2$, and V_{V+} .

Note 2: Continuous short circuit may exceed absolute maximum T_J under some conditions.

AC ELECTRICAL CHARACTERISTICS (5V)

Electrical Characteristics: Unless otherwise indicated, $V_{V+} = +5.0V$, $V_{V-} = 0V$, $V_{CM} = 1.5V$, $V_{OUT} = V_{V+}/2$; $R_L = 1\text{ M}\Omega$; $T_J = 25^\circ\text{C}$, Note 1.

Parameters	Sym.	Min.	Typ.	Max.	Units	Conditions
Total Harmonic Distortion	THD	—	0.05	—	%	$f = 1\text{ kHz}$, $A_V = -2$, $R_L = 2\text{ k}\Omega$, $V_{OUT} = 4.0V_{PP}$
Slew Rate	SR	—	0.5	—	V/ μs	—
Gain-Bandwidth Product	GBWP	—	0.4	—	MHz	—
Phase Margin	ϕ_m	—	85	—	$^\circ$	$C_L = 0\text{ pF}$
		—	40	—	$^\circ$	$C_L = 4500\text{ pF}$
Gain Margin	G_m	—	10	—	dB	—

Note 1: All limits guaranteed by testing or statistical analysis.

DC ELECTRICAL CHARACTERISTICS (10V)

Electrical Characteristics: Unless otherwise indicated, $V_{V+} = +10V$, $V_{V-} = 0V$, $V_{CM} = 1.5V$, $V_{OUT} = V_{V+}/2$; $R_L = 1\text{ M}\Omega$; $T_J = 25^\circ\text{C}$, [Note 1](#).

Parameters	Sym.	Min.	Typ.	Max.	Units	Conditions
Input Offset Voltage	V_{OS}	—	1.0	9	mV	—
Input Offset Voltage Average Drift	TCV_{OS}	—	1.0	—	$\mu\text{V}/^\circ\text{C}$	—
Input Bias Current	I_B	—	0.5	—	pA	—
Input Offset Current	I_{OS}	—	0.25	—	pA	—
Input Resistance	R_{IN}	—	>1	—	$\text{T}\Omega$	—
Common-Mode Rejection Ratio	CMRR	60	85	—	dB	$0V \leq V_{CM} \leq 10V$, Note 2
Input Common-Mode Voltage	V_{CM}	—	-0.3	-0.0	V	Input low, $V_+ = 10V$, CMRR ≥ 60 dB
		10.0	10.3	—	V	Input high, $V_+ = 10V$, CMRR ≥ 60 dB
Power Supply Rejection Ratio	PSRR	55	75	—	dB	$V_{V+} = V_{V-} = 2.5V$ to $5.0V$, $V_{CM} = 0$
Large Signal Voltage Gain	A_V	80	340	—	V/mV	Sourcing or sinking, $R_L = 2\text{ k}\Omega$, Note 3
		15	300	—	V/mV	Sourcing or sinking, $R_L = 600\Omega$, Note 3
Common-Mode Input Capacitance	C_{IN}	—	3	—	pF	—
Output Swing	V_{OUT}	—	0.5	1.5	mV	Output high, $R_L = 100\text{ k}\Omega$, specified as $V_{V+} - V_{OUT}$
		—	—	2.5	mV	Output high, $R_L = 100\text{ k}\Omega$, specified as $V_{V+} - V_{OUT}$, $-40^\circ\text{C} \leq T_J \leq +85^\circ\text{C}$
		—	0.5	1.5	mV	Output low, $R_L = 100\text{ k}\Omega$
		—	—	2.5	mV	Output low, $R_L = 100\text{ k}\Omega$, $-40^\circ\text{C} \leq T_J \leq +85^\circ\text{C}$
		—	24	80	mV	Output high, $R_L = 2\text{ k}\Omega$, specified as $V_{V+} - V_{OUT}$
		—	—	120	mV	Output high, $R_L = 2\text{ k}\Omega$, specified as $V_{V+} - V_{OUT}$, $-40^\circ\text{C} \leq T_J \leq +85^\circ\text{C}$
		—	24	80	mV	Output low, $R_L = 2\text{ k}\Omega$
		—	—	120	mV	Output low, $R_L = 2\text{ k}\Omega$, $-40^\circ\text{C} \leq T_J \leq +85^\circ\text{C}$
		—	80	270	mV	Output high, $R_L = 600\Omega$, specified as $V_{V+} - V_{OUT}$
		—	—	400	mV	Output high, $R_L = 600\Omega$, specified as $V_{V+} - V_{OUT}$, $-40^\circ\text{C} \leq T_J \leq +85^\circ\text{C}$
		—	80	270	mV	Output low, $R_L = 600\Omega$
		—	—	400	mV	Output low, $R_L = 600\Omega$, $-40^\circ\text{C} \leq T_J \leq +85^\circ\text{C}$

MIC7300

DC ELECTRICAL CHARACTERISTICS (10V) (CONTINUED)

Electrical Characteristics: Unless otherwise indicated, $V_{V+} = +10V$, $V_{V-} = 0V$, $V_{CM} = 1.5V$, $V_{OUT} = V_{V+}/2$; $R_L = 1\text{ M}\Omega$; $T_J = 25^\circ\text{C}$, [Note 1](#).

Parameters	Sym.	Min.	Typ.	Max.	Units	Conditions
Output Short Circuit Current	I_{SC}	90	115	—	mA	Sinking or sourcing (Note 4)
Supply Current	I_S	—	1.5	4.0	mA	$V_{OUT} = V+/2$

Note 1: All limits guaranteed by testing or statistical analysis.

2: CMRR is determined as follows: The maximum ΔV_{OS} over the V_{CM} range is divided by the magnitude of the V_{CM} range. The measurement points are: V_{V-} , $(V_{V+} - V_{V-})/2$, and V_{V+} .

3: R_L connected to 5V. Sourcing: $5V \leq V_{OUT} \leq 10V$. Sinking: $2.5V \leq V_{OUT} \leq 5V$.

4: Continuous short circuit may exceed absolute maximum T_J under some conditions..

AC ELECTRICAL CHARACTERISTICS (10V)

Electrical Characteristics: Unless otherwise indicated, $V_{V+} = 10V$, $V_{V-} = 0V$, $V_{CM} = 1.5V$, $V_{OUT} = V_{V+}/2$; $R_L = 1\text{ M}\Omega$; $T_J = 25^\circ\text{C}$, [Note 1](#).

Parameters	Sym.	Min.	Typ.	Max.	Units	Conditions
Total Harmonic Distortion	THD	—	0.01	—	%	$f = 1\text{ kHz}$, $A_V = -2$, $R_L = 2\text{ k}\Omega$, $V_{OUT} = 8.5V_{PP}$
Slew Rate	SR	—	0.5	—	V/ μs	$V+ = 10V$, Note 2
Gain-Bandwidth Product	GBWP	—	0.37	—	MHz	—
Phase Margin	ϕ_m	—	85	—	$^\circ$	$C_L = 0\text{ pF}$
		—	40	—	$^\circ$	$C_L = 6000\text{ pF}$
Gain Margin	G_m	—	10	—	dB	—
Input-Referred Voltage Noise	e_n	—	37	—	nV/ $\sqrt{\text{Hz}}$	$f = 1\text{ kHz}$, $V_{CM} = 1V$
Input-Referred Current Noise	i_n	—	1.5	—	fA/ $\sqrt{\text{Hz}}$	$f = 1\text{ kHz}$

Note 1: All limits guaranteed by testing or statistical analysis.

2: Device connected as a voltage follower with a 10V step input. The value is the positive or negative slew rate, whichever is slower.

TEMPERATURE SPECIFICATIONS

Parameters	Sym.	Min.	Typ.	Max.	Units	Conditions
Temperature Ranges						
Junction Operating Temperature	T_J	-40	—	+85	$^\circ\text{C}$	—
Maximum Junction Temperature	T_J	—	—	+150	$^\circ\text{C}$	—
Storage Temperature Range	T_S	-65	—	+150	$^\circ\text{C}$	—
Lead Temperature	—	—	+260	—	$^\circ\text{C}$	soldering, 10 sec.
Package Thermal Resistances						
Thermal Resistance, SOT-23-5Ld	θ_{JA}	—	260	—	$^\circ\text{C/W}$	—
Thermal Resistance, MSOP-8Ld	θ_{JA}	—	85	—	$^\circ\text{C/W}$	—

2.0 TYPICAL PERFORMANCE CURVES

Note: The graphs and tables provided following this note are a statistical summary based on a limited number of samples and are provided for informational purposes only. The performance characteristics listed herein are not tested or guaranteed. In some graphs or tables, the data presented may be outside the specified operating range (e.g., outside specified power supply range) and therefore outside the warranted range.

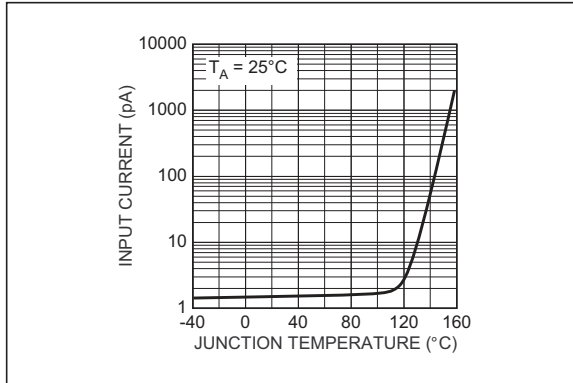

FIGURE 2-1: *Input Current vs. Junction Temperature.*

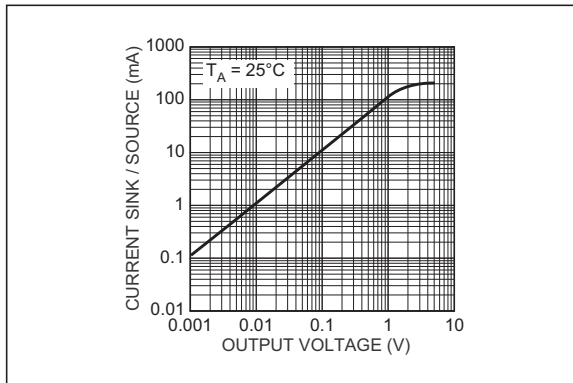

FIGURE 2-2: *Sink/Source Currents vs. Output Voltage.*

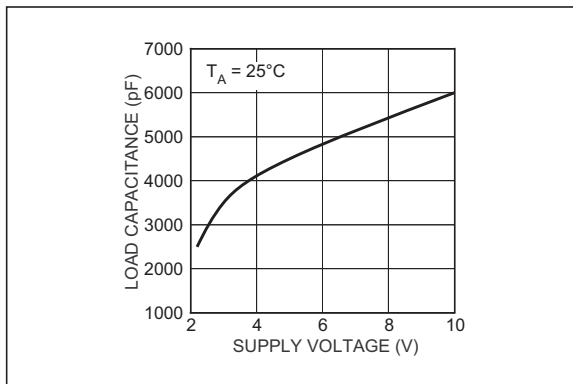

FIGURE 2-3: *Capacitive Load Capability vs. Supply Voltage.*

MIC7300

3.0 PIN DESCRIPTIONS

The descriptions of the pins are listed in [Table 3-1](#).

TABLE 3-1: PIN FUNCTION TABLE

MIC7300 MSOP-8	MIC7300 SOT-23-5	Symbol	Description
4	1	OUT	Amplifier Output.
5-8	2	V-	Negative Supply. Negative supply for split-supply application or ground for single-supply application.
3	3	IN+	Noninverting Input.
2	4	IN-	Inverting Input.
1	5	V+	Positive Supply.

4.0 APPLICATION INFORMATION

4.1 Input Common-Mode Voltage

The MIC7300 tolerates input overdrive by at least 300 mV beyond either rail without producing phase inversion.

If the absolute maximum input voltage is exceeded, the input current should be limited to ± 5 mA maximum to prevent reducing reliability. A 10 k Ω series input resistor, used as a current limiter, will protect the input structure from voltages as large as 50V above the supply or below ground. See [Figure 4-1](#).

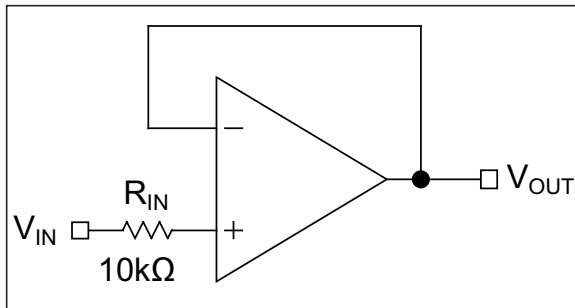

FIGURE 4-1: Input Current-Limit Protection.

4.2 Output Voltage Swing

Sink and source output resistances of the MIC7300 are equal. Maximum output voltage swing is determined by the load and the approximate output resistance. The output resistance is shown in [Equation 4-1](#).

EQUATION 4-1:

$$R_{OUT} = \frac{V_{DROP}}{I_{LOAD}}$$

V_{DROP} is the voltage dropped within the amplifier output stage. V_{DROP} and I_{LOAD} can be determined from the V_O (output swing) portion of the appropriate [Electrical Characteristics](#) table. I_{LOAD} is equal to the typical output high voltage minus V_{+/2} and divided by R_{LOAD}. For example, using the 5V table, the typical output high voltage using a 2 k Ω load (connected to V_{+/2}) is 4.985V, which produces an I_{LOAD} of:

EQUATION 4-2:

$$\left(\frac{4.985V - 2.5V}{2k\Omega} \right) = 1.243mA$$

Voltage drop in the amplifier output stage is:

EQUATION 4-3:

$$V_{DROP} = 5.0V - 4.985V = 0.015V$$

Because of output stage symmetry, the corresponding typical output low voltage (0.015V) also equals V_{DROP}. Then:

EQUATION 4-4:

$$R_{OUT} = \frac{0.015V}{0.001243A} = 12\Omega$$

4.3 Power Dissipation

The MIC7300 output drive capability requires considering power dissipation. If the load impedance is low, it is possible to damage the device by exceeding the maximum junction temperature rating.

On-chip power consists of two components: supply power and output stage power. Supply power (P_S) is the product of the supply voltage (V_S = V_{V+} - V_{V-}) and supply current (I_S).

Output stage power (P_O) is the product of the output stage voltage drop (V_{DROP}) and the output (load) current (I_{OUT}). Total on-chip power dissipation is:

EQUATION 4-5:

$$P_D = P_S + P_O$$

Where:

P_D = Total on-chip power

P_S = Supply power dissipation

P_O = Output power dissipation

EQUATION 4-6:

$$P_D = V_S I_S + V_{DROP} I_{OUT}$$

Where:

V_S = V_{V+} - V_{V-}

I_S = Power supply current

V_{DROP} = V_{V+} - V_{OUT} (sourcing current)

V_{DROP} = V_{OUT} - V_{V-} (sinking current)

[Equation 4-5](#) and [4-6](#) address only steady state (DC) conditions. For non-DC conditions the user must estimate power dissipation based on the RMS value of the signal.

The task is one of determining the allowable on-chip power dissipation for operation at a given ambient temperature and power supply voltage. From this

MIC7300

determination, one may calculate the maximum allowable power dissipation and, after subtracting P_S , determine the maximum allowable load current, which in turn can be used to determine the minimum load impedance that may safely be driven. The calculation is summarized below.

EQUATION 4-7:

$$P_{D(max)} = \frac{T_{J(max)} - T_A}{\theta_{JA}}$$

$$\theta_{JA(SOT-23-5)} = 260^\circ\text{C/W}$$

$$\theta_{JA(MSOP-8)} = 85^\circ\text{C/W}$$

4.4 Driving Capacitive Loads

Driving a capacitive load introduces phase-lag into the output signal, and this in turn reduces op-amp system phase margin. The application that is least forgiving of reduced phase margin is a unity gain amplifier. The MIC7300 can typically drive a 2500 pF capacitive load connected directly to the output when configured as a unity-gain amplifier and powered with a 2.2V supply. At 10V operation the circuit typically drives 6000 pF. Phase margin is typically 40 degrees.

4.5 Using Large-Value Feedback Resistors

A large-value feedback resistor ($> 500 \text{ k}\Omega$) can reduce the phase margin of a system. This occurs when the feedback resistor acts in conjunction with input capacitance to create phase lag in the feedback signal. Input capacitance is usually a combination of input circuit components and other parasitic capacitance, such as amplifier input capacitance and stray printed circuit board capacitance.

Figure 4-2 illustrates a method of compensating phase lag caused by using a large-value feedback resistor. Feedback capacitor C_{FB} introduces sufficient phase lead to overcome the phase lag caused by feedback resistor R_{FB} and input capacitance C_{IN} . The value of C_{FB} is determined by first estimating C_{IN} and then applying the following formula shown in Equation 4-8:

EQUATION 4-8:

$$R_{IN} \times C_{IN} \leq R_{FB} \times C_{FB}$$

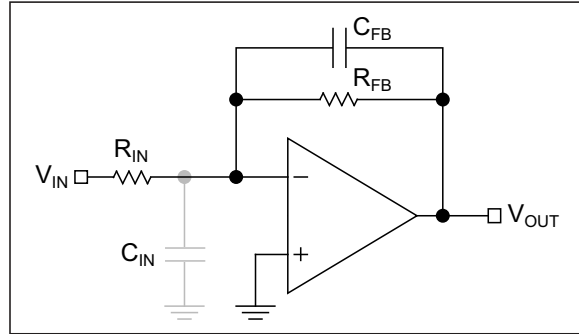

FIGURE 4-2: Canceling Feedback Phase Lag.

Because a significant percentage of C_{IN} may be caused by board layout, it is important to note that the correct value of C_{FB} may change when changing from a breadboard to the final circuit layout.

4.6 Typical Circuits

Some single-supply, rail-to-rail applications for which the MIC7300 is well suited are shown in the circuit diagrams of Figure 4-3 through Figure 4-8.

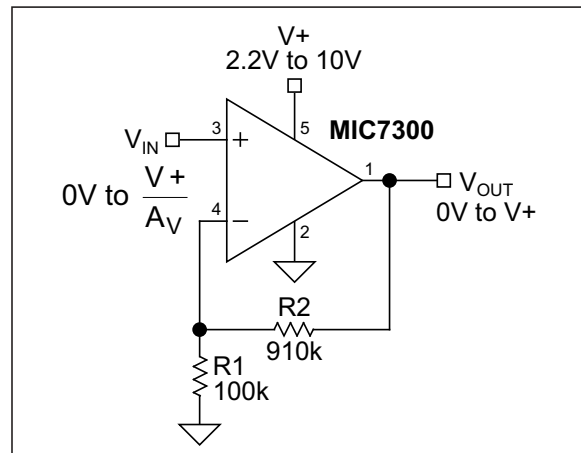

FIGURE 4-3: Non-Inverting Amplifier.

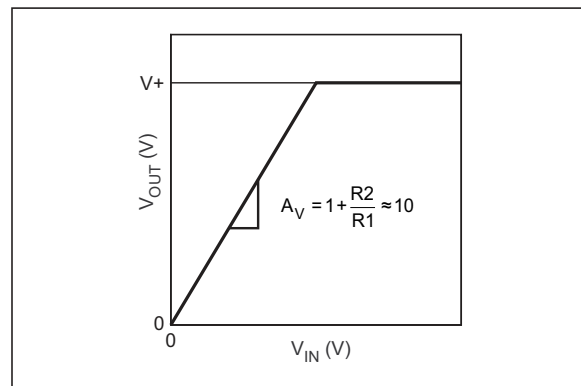

FIGURE 4-4: Non-Inverting Amplifier Behavior.

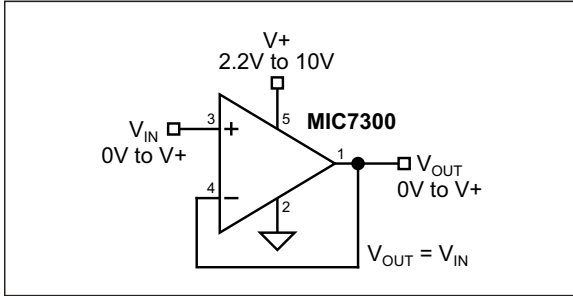

FIGURE 4-5: Voltage Follower/Buffer.

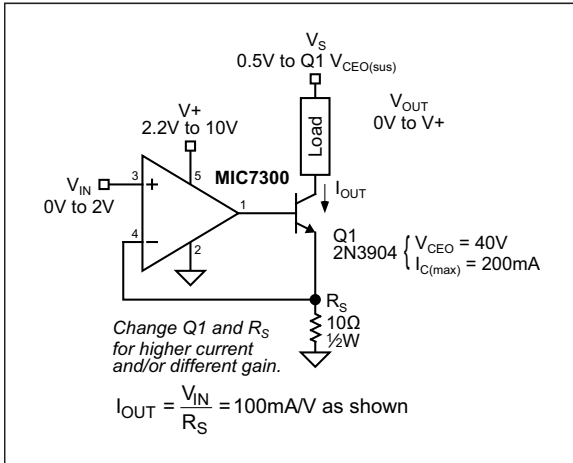

FIGURE 4-6: Voltage-Controlled Current Sink.

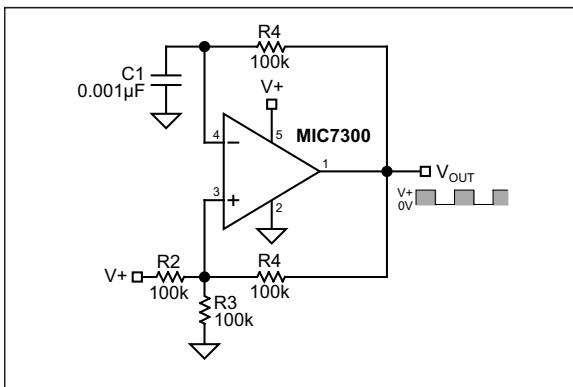

FIGURE 4-7: Square Wave Oscillator.

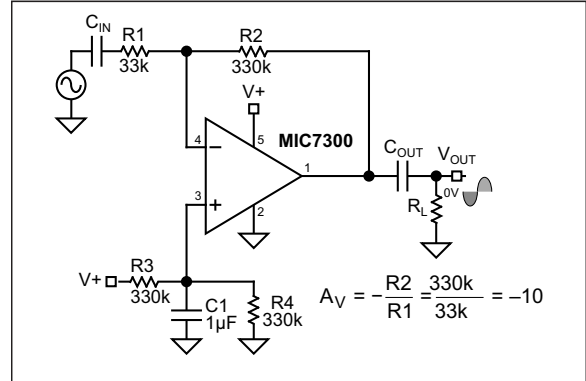
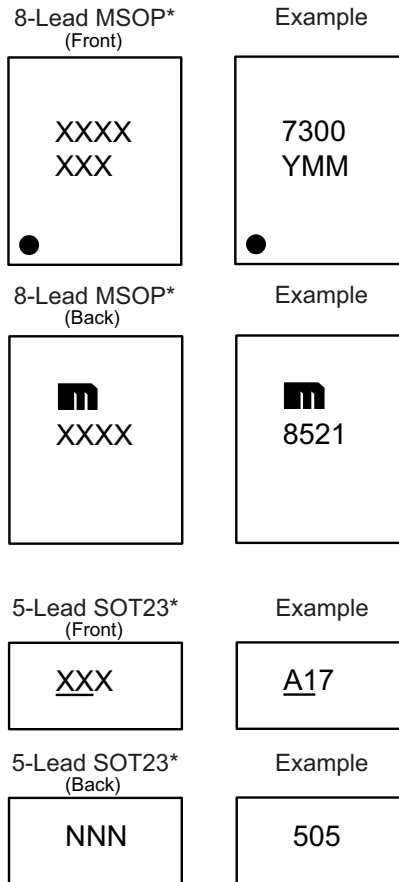

FIGURE 4-8: AC-Coupled Inverting Amplifier.

MIC7300

5.0 PACKAGING INFORMATION

5.1 Package Marking Information



<p>Legend: XX...X Product code or customer-specific information Y Year code (last digit of calendar year) YY Year code (last 2 digits of calendar year) WW Week code (week of January 1 is week '01') NNN Alphanumeric traceability code Ⓔ Pb-free JEDEC® designator for Matte Tin (Sn) * This package is Pb-free. The Pb-free JEDEC designator (Ⓔ) can be found on the outer packaging for this package.</p> <p>●, ▲, ▼ Pin one index is identified by a dot, delta up, or delta down (triangle mark).</p>
<p>Note: In the event the full Microchip part number cannot be marked on one line, it will be carried over to the next line, thus limiting the number of available characters for customer-specific information. Package may or may not include the corporate logo.</p> <p>Underbar () and/or Overbar () symbol may not be to scale.</p>

5-Lead SOT-23 Package Outline and Recommended Land Pattern

TITLE

5 LEAD SOT23 PACKAGE OUTLINE & RECOMMENDED LAND PATTERN

DRAWING #	SOT23-5LD-PL-1	UNIT	MM
------------------	----------------	-------------	----

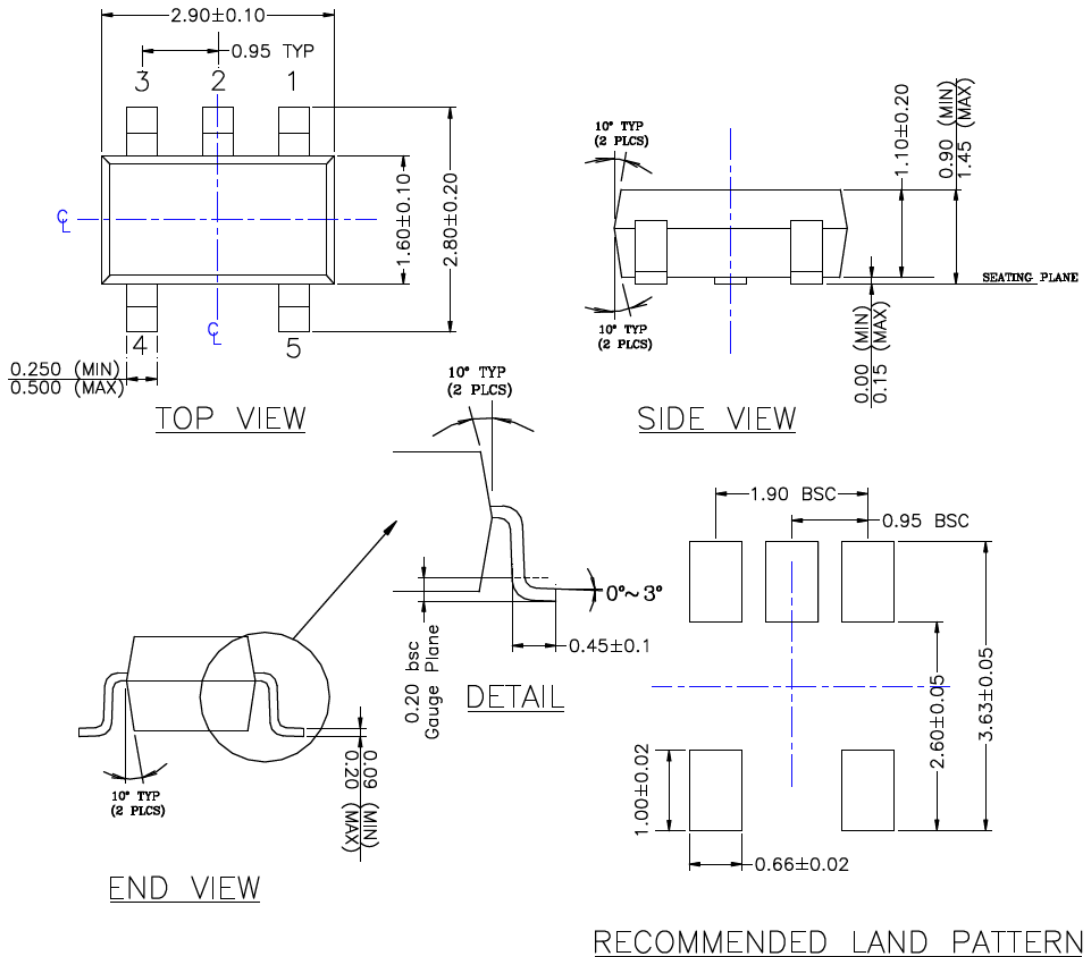

- NOTE:
1. PACKAGE OUTLINE EXCLUSIVE OF MOLD FLASH & BURR.
 2. PACKAGE OUTLINE INCLUSIVE OF SOLER PLATING.
 3. DIMENSION AND TOLERANCE PER ANSI Y14.5M, 1982.
 4. FOOT LENGTH MEASUREMENT BASED ON GAUGE PLANE METHOD.
 5. DIE FACES UP FOR MOLD, AND FACES DOWN FOR TRIM/FORM.
 6. ALL DIMENSIONS ARE IN MILLIMETERS.

Note: For the most current package drawings, please see the Microchip Packaging Specification located at <http://www.microchip.com/packaging>.

MIC7300

8-Lead MSOP Package Outline and Recommended Land Pattern

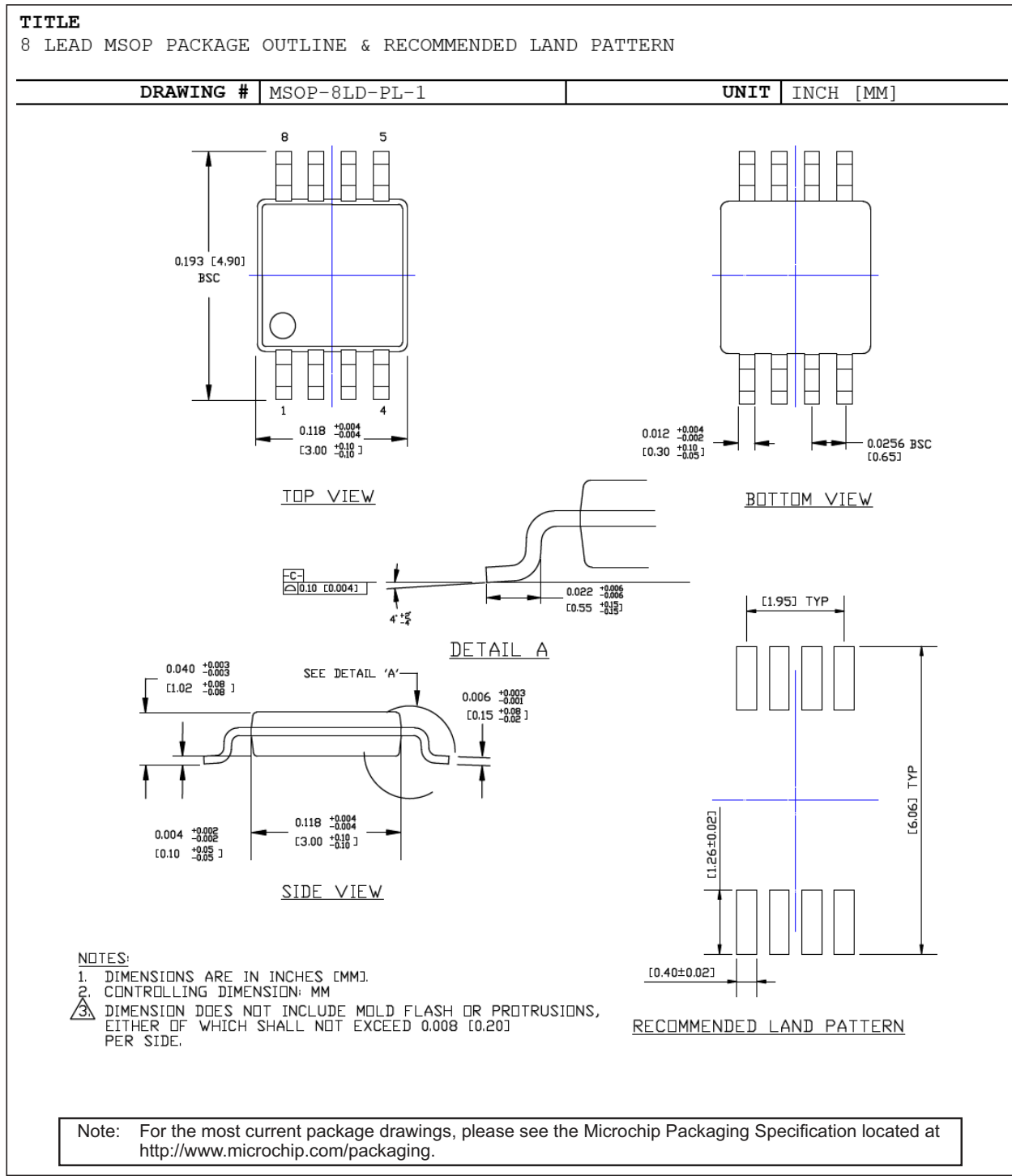

APPENDIX A: REVISION HISTORY

Revision A (February 2020)

- Converted Micrel document MIC7300 to Microchip data sheet template DS20006305A.
- Minor text changes throughout.

MIC7300

NOTES:

PRODUCT IDENTIFICATION SYSTEM

To order or obtain information, e.g., on pricing or delivery, contact your local Microchip representative or sales office.

<u>PART NO.</u>	<u>X</u>	<u>XX</u>	<u>-XX</u>
Device	Temperature Range	Package Option	Media Type
Device:	MIC7300:	High-Output Drive Rail-to-Rail Op Amp	
Temperature Range:	Y =	-40°C to +85°C (RoHS Compliant)	
Package Option:	M5 =	5-Lead SOT-23	
	MM =	8-Lead MSOP	
Media Type:	<blank>=	100/Tube (MSOP only)	
	TR =	2,500/Reel (MSOP only)	
	TR =	3,000/Reel (SOT-23 only)	
Examples:			
a) MIC7300YM5-TR: MIC7300, -40°C to +85°C Temperature Range, 5-Lead SOT-23, 3,000/Reel			
b) MIC7300YMM: MIC7300, -40°C to +85°C Temperature Range, 8-Lead MSOP, 100/Tube			
c) MIC7300YMM-TR: MIC7300, -40°C to +85°C Temperature Range, 8-Lead MSOP, 2,500/Reel			
Note 1: Tape and Reel identifier only appears in the catalog part number description. This identifier is used for ordering purposes and is not printed on the device package. Check with your Microchip Sales Office for package availability with the Tape and Reel option.			

MIC7300

NOTES:

Note the following details of the code protection feature on Microchip devices:

- Microchip products meet the specification contained in their particular Microchip Data Sheet.
- Microchip believes that its family of products is one of the most secure families of its kind on the market today, when used in the intended manner and under normal conditions.
- There are dishonest and possibly illegal methods used to breach the code protection feature. All of these methods, to our knowledge, require using the Microchip products in a manner outside the operating specifications contained in Microchip's Data Sheets. Most likely, the person doing so is engaged in theft of intellectual property.
- Microchip is willing to work with the customer who is concerned about the integrity of their code.
- Neither Microchip nor any other semiconductor manufacturer can guarantee the security of their code. Code protection does not mean that we are guaranteeing the product as “unbreakable.”

Code protection is constantly evolving. We at Microchip are committed to continuously improving the code protection features of our products. Attempts to break Microchip's code protection feature may be a violation of the Digital Millennium Copyright Act. If such acts allow unauthorized access to your software or other copyrighted work, you may have a right to sue for relief under that Act.

Information contained in this publication regarding device applications and the like is provided only for your convenience and may be superseded by updates. It is your responsibility to ensure that your application meets with your specifications. MICROCHIP MAKES NO REPRESENTATIONS OR WARRANTIES OF ANY KIND WHETHER EXPRESS OR IMPLIED, WRITTEN OR ORAL, STATUTORY OR OTHERWISE, RELATED TO THE INFORMATION, INCLUDING BUT NOT LIMITED TO ITS CONDITION, QUALITY, PERFORMANCE, MERCHANTABILITY OR FITNESS FOR PURPOSE. Microchip disclaims all liability arising from this information and its use. Use of Microchip devices in life support and/or safety applications is entirely at the buyer's risk, and the buyer agrees to defend, indemnify and hold harmless Microchip from any and all damages, claims, suits, or expenses resulting from such use. No licenses are conveyed, implicitly or otherwise, under any Microchip intellectual property rights unless otherwise stated.

Trademarks

The Microchip name and logo, the Microchip logo, Adaptec, AnyRate, AVR, AVR logo, AVR Freaks, BesTime, BitCloud, chipKIT, chipKIT logo, CryptoMemory, CryptoRF, dsPIC, FlashFlex, flexPWR, HELDO, IGLOO, JukeBlox, KeeLoq, Klear, LANCheck, LinkMD, maXStylus, maXTouch, MediaLB, megaAVR, Microsemi, Microsemi logo, MOST, MOST logo, MPLAB, OptoLyzer, PackeTime, PIC, picoPower, PICSTART, PIC32 logo, PolarFire, Prochip Designer, QTouch, SAM-BA, SenGenuity, SpyNIC, SST, SST Logo, SuperFlash, Symmetricom, SyncServer, Tachyon, TempTrackr, TimeSource, tinyAVR, UNI/O, Vectron, and XMEGA are registered trademarks of Microchip Technology Incorporated in the U.S.A. and other countries.

APT, ClockWorks, The Embedded Control Solutions Company, EtherSynch, FlashTec, Hyper Speed Control, HyperLight Load, IntelliMOS, Libero, motorBench, mTouch, Powermite 3, Precision Edge, ProASIC, ProASIC Plus, ProASIC Plus logo, Quiet-Wire, SmartFusion, SyncWorld, Temux, TimeCesium, TimeHub, TimePictra, TimeProvider, Vite, WinPath, and ZL are registered trademarks of Microchip Technology Incorporated in the U.S.A.

Adjacent Key Suppression, AKS, Analog-for-the-Digital Age, Any Capacitor, AnyIn, AnyOut, BlueSky, BodyCom, CodeGuard, CryptoAuthentication, CryptoAutomotive, CryptoCompanion, CryptoController, dsPICDEM, dsPICDEM.net, Dynamic Average Matching, DAM, ECAN, EtherGREEN, In-Circuit Serial Programming, ICSP, INICnet, Inter-Chip Connectivity, JitterBlocker, KlearNet, KlearNet logo, memBrain, Mindi, MiWi, MPASM, MPF, MPLAB Certified logo, MPLIB, MPLINK, MultiTRAK, NetDetach, Omniscient Code Generation, PICDEM, PICDEM.net, PICKit, PICtail, PowerSmart, PureSilicon, QMatrix, REAL ICE, Ripple Blocker, SAM-ICE, Serial Quad I/O, SMART-I.S., SQI, SuperSwitcher, SuperSwitcher II, Total Endurance, TSHARC, USBCheck, VariSense, ViewSpan, WiperLock, Wireless DNA, and ZENA are trademarks of Microchip Technology Incorporated in the U.S.A. and other countries.

SQTP is a service mark of Microchip Technology Incorporated in the U.S.A.

The Adaptec logo, Frequency on Demand, Silicon Storage Technology, and Symmcom are registered trademarks of Microchip Technology Inc. in other countries.

GestIC is a registered trademark of Microchip Technology Germany II GmbH & Co. KG, a subsidiary of Microchip Technology Inc., in other countries.

All other trademarks mentioned herein are property of their respective companies.

© 2020, Microchip Technology Incorporated, All Rights Reserved.

ISBN: 978-1-5224-5636-0

For information regarding Microchip's Quality Management Systems, please visit www.microchip.com/quality.



MICROCHIP

Worldwide Sales and Service

AMERICAS

Corporate Office
2355 West Chandler Blvd.
Chandler, AZ 85224-6199
Tel: 480-792-7200
Fax: 480-792-7277
Technical Support:
<http://www.microchip.com/support>
Web Address:
www.microchip.com

Atlanta
Duluth, GA
Tel: 678-957-9614
Fax: 678-957-1455

Austin, TX
Tel: 512-257-3370

Boston
Westborough, MA
Tel: 774-760-0087
Fax: 774-760-0088

Chicago
Itasca, IL
Tel: 630-285-0071
Fax: 630-285-0075

Dallas
Addison, TX
Tel: 972-818-7423
Fax: 972-818-2924

Detroit
Novi, MI
Tel: 248-848-4000

Houston, TX
Tel: 281-894-5983

Indianapolis
Noblesville, IN
Tel: 317-773-8323
Fax: 317-773-5453
Tel: 317-536-2380

Los Angeles
Mission Viejo, CA
Tel: 949-462-9523
Fax: 949-462-9608
Tel: 951-273-7800

Raleigh, NC
Tel: 919-844-7510

New York, NY
Tel: 631-435-6000

San Jose, CA
Tel: 408-735-9110
Tel: 408-436-4270

Canada - Toronto
Tel: 905-695-1980
Fax: 905-695-2078

ASIA/PACIFIC

Australia - Sydney
Tel: 61-2-9868-6733

China - Beijing
Tel: 86-10-8569-7000

China - Chengdu
Tel: 86-28-8665-5511

China - Chongqing
Tel: 86-23-8980-9588

China - Dongguan
Tel: 86-769-8702-9880

China - Guangzhou
Tel: 86-20-8755-8029

China - Hangzhou
Tel: 86-571-8792-8115

China - Hong Kong SAR
Tel: 852-2943-5100

China - Nanjing
Tel: 86-25-8473-2460

China - Qingdao
Tel: 86-532-8502-7355

China - Shanghai
Tel: 86-21-3326-8000

China - Shenyang
Tel: 86-24-2334-2829

China - Shenzhen
Tel: 86-755-8864-2200

China - Suzhou
Tel: 86-186-6233-1526

China - Wuhan
Tel: 86-27-5980-5300

China - Xian
Tel: 86-29-8833-7252

China - Xiamen
Tel: 86-592-2388138

China - Zhuhai
Tel: 86-756-3210040

ASIA/PACIFIC

India - Bangalore
Tel: 91-80-3090-4444

India - New Delhi
Tel: 91-11-4160-8631

India - Pune
Tel: 91-20-4121-0141

Japan - Osaka
Tel: 81-6-6152-7160

Japan - Tokyo
Tel: 81-3-6880-3770

Korea - Daegu
Tel: 82-53-744-4301

Korea - Seoul
Tel: 82-2-554-7200

Malaysia - Kuala Lumpur
Tel: 60-3-7651-7906

Malaysia - Penang
Tel: 60-4-227-8870

Philippines - Manila
Tel: 63-2-634-9065

Singapore
Tel: 65-6334-8870

Taiwan - Hsin Chu
Tel: 886-3-577-8366

Taiwan - Kaohsiung
Tel: 886-7-213-7830

Taiwan - Taipei
Tel: 886-2-2508-8600

Thailand - Bangkok
Tel: 66-2-694-1351

Vietnam - Ho Chi Minh
Tel: 84-28-5448-2100

EUROPE

Austria - Wels
Tel: 43-7242-2244-39
Fax: 43-7242-2244-393

Denmark - Copenhagen
Tel: 45-4450-2828
Fax: 45-4485-2829

Finland - Espoo
Tel: 358-9-4520-820

France - Paris
Tel: 33-1-69-53-63-20
Fax: 33-1-69-30-90-79

Germany - Garching
Tel: 49-8931-9700

Germany - Haan
Tel: 49-2129-3766400

Germany - Heilbronn
Tel: 49-7131-72400

Germany - Karlsruhe
Tel: 49-721-625370

Germany - Munich
Tel: 49-89-627-144-0
Fax: 49-89-627-144-44

Germany - Rosenheim
Tel: 49-8031-354-560

Israel - Ra'anana
Tel: 972-9-744-7705

Italy - Milan
Tel: 39-0331-742611
Fax: 39-0331-466781

Italy - Padova
Tel: 39-049-7625286

Netherlands - Drunen
Tel: 31-416-690399
Fax: 31-416-690340

Norway - Trondheim
Tel: 47-7288-4388

Poland - Warsaw
Tel: 48-22-3325737

Romania - Bucharest
Tel: 40-21-407-87-50

Spain - Madrid
Tel: 34-91-708-08-90
Fax: 34-91-708-08-91

Sweden - Gothenberg
Tel: 46-31-704-60-40

Sweden - Stockholm
Tel: 46-8-5090-4654

UK - Wokingham
Tel: 44-118-921-5800
Fax: 44-118-921-5820