

KITPFGMEVME Rev B Programmer

for PF Series Power Management Devices



Figure 1. The PF Programmer (KITPFGMEVME)

Contents

1 Kit Contents / Packing List	2
2 Jump Start	2
3 Important Notice	4
4 Introduction	4
5 Features	4
6 Hardware Design and Requirements	4
7 References	8
8 Revision History	9

1 Kit Contents / Packing List

- KITPFPGMEVME PF Series Programmer
- Flat ribbon cable (8-conductor)
- Mini USB cable
- Quick start guide
- Technical support brochure
- Warranty card

2 Jump Start

- Go to www.freescale.com/analogtools
- Locate your kit
- Review your Tool Summary Page
- Look for



Jump Start Your Design

- Download documents, software and other information

3 Important Notice

Freescale provides the enclosed product(s) under the following conditions:

This evaluation kit is intended for use of ENGINEERING DEVELOPMENT OR EVALUATION PURPOSES ONLY. It is provided as a sample IC pre-soldered to a printed circuit board to make it easier to access inputs, outputs, and supply terminals. This EVB may be used with any development system or other source of I/O signals by simply connecting it to the host MCU or computer board via off-the-shelf cables. This EVB is not a Reference Design and is not intended to represent a final design recommendation for any particular application. Final device in an application will be heavily dependent on proper printed circuit board layout and heat sinking design as well as attention to supply filtering, transient suppression, and I/O signal quality.

The goods provided may not be complete in terms of required design, marketing, and or manufacturing related protective considerations, including product safety measures typically found in the end product incorporating the goods. Due to the open construction of the product, it is the user's responsibility to take any and all appropriate precautions with regard to electrostatic discharge. In order to minimize risks associated with the customers applications, adequate design and operating safeguards must be provided by the customer to minimize inherent or procedural hazards. For any safety concerns, contact Freescale sales and technical support services.

Should this evaluation kit not meet the specifications indicated in the kit, it may be returned within 30 days from the date of delivery and will be replaced by a new kit.

Freescale reserves the right to make changes without further notice to any products herein. Freescale makes no warranty, representation or guarantee regarding the suitability of its products for any particular purpose, nor does Freescale assume any liability arising out of the application or use of any product or circuit, and specifically disclaims any and all liability, including without limitation consequential or incidental damages. "Typical" parameters can and do vary in different applications and actual performance may vary over time. All operating parameters, including "Typical", must be validated for each customer application by customer's technical experts.

Freescale does not convey any license under its patent rights nor the rights of others. Freescale products are not designed, intended, or authorized for use as components in systems intended for surgical implant into the body, or other applications intended to support or sustain life, or for any other application in which the failure of the Freescale product could create a situation where personal injury or death may occur.

Should the Buyer purchase or use Freescale products for any such unintended or unauthorized application, the Buyer shall indemnify and hold Freescale and its officers, employees, subsidiaries, affiliates, and distributors harmless against all claims, costs, damages, and expenses, and reasonable attorney fees arising out of, directly or indirectly, any claim of personal injury or death associated with such unintended or unauthorized use, even if such claim alleges that Freescale was negligent regarding the design or manufacture of the part. Freescale™ and the Freescale logo are trademarks of Freescale Semiconductor, Inc. All other product or service names are the property of their respective owners.

© Freescale Semiconductor, Inc. 2013

4 Introduction

The KITPFGMEVME development tool, also known as the PF Programmer, is a standalone device designed for configuring and programming the SMARTMOS PF Family of Power Management Integrated Circuit devices. It is designed to control and program PF devices on customer application boards through an 8-pin header interface, as well as the KITPF0100SKTEVBE programming socket device for OTP programming of standalone PF devices.

The scope of this document is to outline the minimum hardware requirements to keep in mind during application design planning, using the KITPFGMEVME interface to communicate with the PF Device. For more detail on the software supported by the KITPFGMEVME, refer to the KTFPSWUG4.pdf document that can be found at Freescale.com.

5 Features

- Plug and Play USB-I2C communication interface
- 3.3 V Main PMIC supply
- 8.5 V Supply for OTP programming
- One dedicated output for PWRON control on PF devices
- Two general purpose logic outputs

6 Hardware Design and Requirements

The KITPFGMEVME Programmer is a development tool designed to provide easy configuration of the PF series devices, and to facilitate prototyping and programming the device's one-time programmable (OTP) fuses. The programmer kit comes with a PF series programmer, a flat ribbon cable (8-conductor) and a mini-USB cable, as shown in [Figure 2](#).



Figure 2. KITPFGMEVME PF Series Programmer

The KITPFGMEVME incorporates a MC9S908JM60 8-bit MCU, a boost regulator, and a 3.3 V LDO. The programming voltage is supplied by the boost regulator, which boosts the nominal 5.0 V from the USB port to the required 8.5 to 9.5 V VDDOTP voltage.

The programmer is connected to the customer's board via a flat cable with a standard 8-pin (4x2), 100 mil pitch header plug. Figure 3 shows the pin-out and signals of the Programming Interface connector.

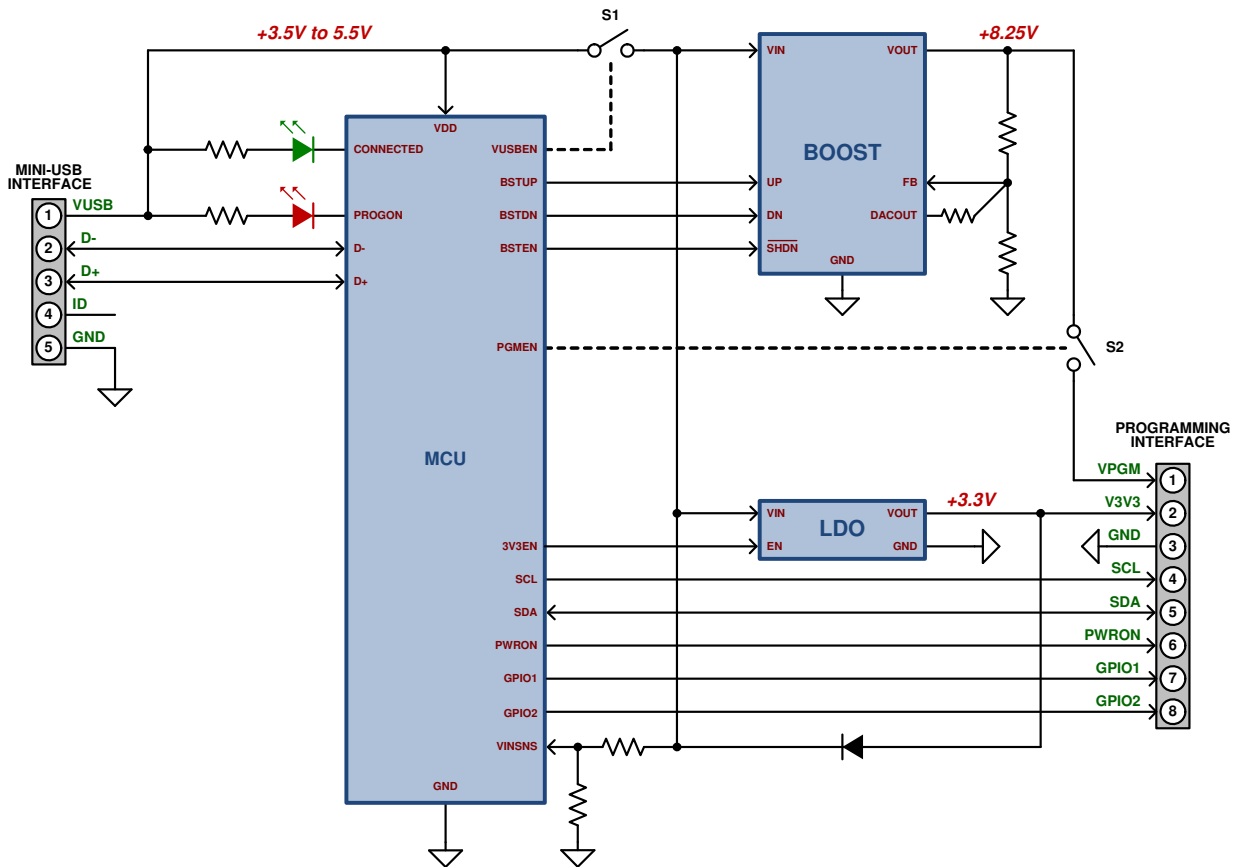

Figure 3. KITPFGMEVME Block Diagram

6.1 Hardware Requirements

- PC with Windows XP or Windows 7 operating system
- Standard USB port
- 8-pin (4x2) 100 mil IDC male connector on target board (recommended)

6.2 Software Requirements

Necessary software and drivers include:

- KITPFGUI4.0.zip: Graphical User Interface (GUI) for PF family of Power Management Integrated Circuits.

Download the latest version of KITPFGUI 4.0.zip and the KTPFSWUG4.pdf user manual from Freescale.com.

6.3 Designing the Target Application

When connecting the KITPFPGMMEVME programmer to an application board with an i.MX processor and a PF device sharing the I²C bus, it is required to disconnect the processor I²C lines from the communication bus.

Figure 4 shows a simplified diagram to program the PF Device with the KITPFPGMMEVME programmer.

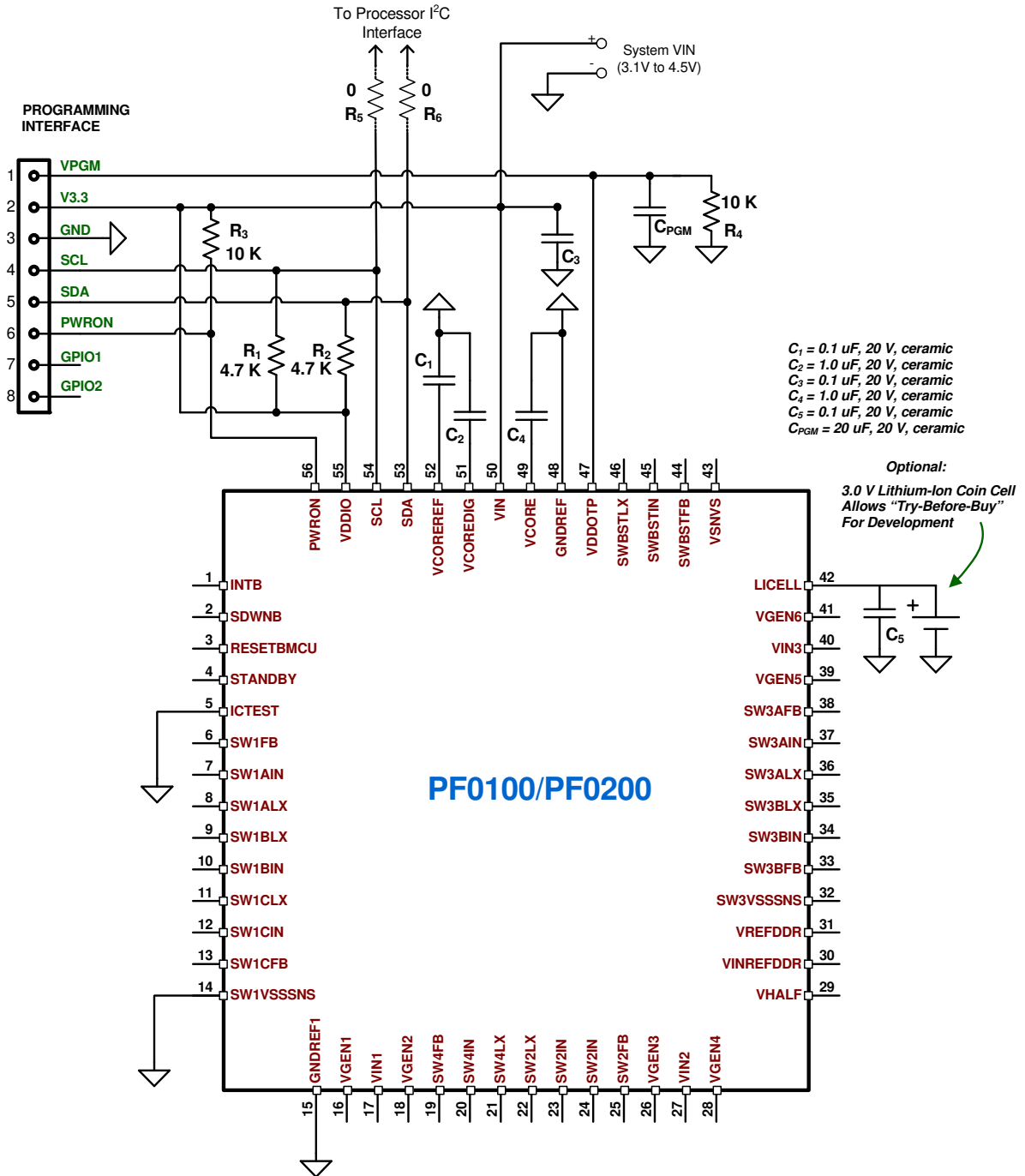

Figure 4. PF Device Minimum System for Programming

Since programming the OTP fuse on the PF Device is a one-time event during production, the most simple and cost-effective solution for isolating the processor I²C lines is to add two 0 Ω resistors (R5 and R6), which should not be placed during OTP programming, but are soldered down for normal operation. Note that Figure 4 represents only a recommended configuration; It is the customer’s responsibility to make sure this proposal meets the requirements of a specific application. The PWRON pin is configured to be LOW, therefore the RESETBMCU will be low, keeping the the processor in reset. The ICTEST pin should be grounded in the application design.

6.4 8-pin Interface Connector

The KITPFGMEVME programmer is prepared to connect to the target board using the supplied 8-conductor flat ribbon cable. The flat cable is keyed so that the correct header pins are connected on both the programmer and the target board.

WARNING: If using a standard 100 mil 8-pin header, verify the brown wire on the other end of the flat cable is connected to pin 1 on your target board header. Freescale recommends a shrouded pin header (TST-104-01-G-D) be placed on the target board, to prevent the cable from being incorrectly inserted into the header and damaging your board.

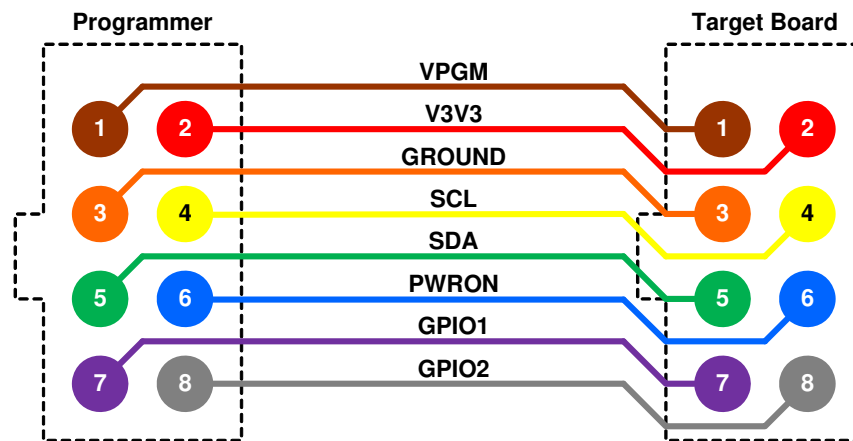

Figure 5. Ribbon Cable Wiring Diagram

Table 1. Pin Description

PIN	NAME	FUNCTION
1	VPGM	Programming voltage for OTP fuses
2	V3V3	Auxiliary 3.3 V supply
3	GND	Ground
4	SCL	I ² C Master clock
5	SDA	I ² C Master data
6	PWRON	Logic output to turn-on/turn-off the PMIC
7	GPIO1	GPIO signal from MCU (open drain)
8	GPIO2	GPIO signal from MCU (logic output)

7 References

Document Number	Description	URL
PF Programmer		
KITPFGMEVME	Tool Summary Page	http://www.freescale.com/KITPFGMEVME
PF PMIC		
MMPF0100	Data Sheet	http://cache.freescale.com/files/analog/doc/data_sheet/MMPF0100.pdf
MMPF0100ER	Errata	http://cache.freescale.com/files/analog/doc/errata/MMPF0100ER.pdf
MMPF0200	Data Sheet	Page under development
MMPF0200ER	Errata	Page under development
KTPFSWUG4	PF Family Software User Guide	http://cache.freescale.com/files/analog/doc/user_guide/KTPFSWUG4.pdf
PFSERIESFS	Fact Sheet	http://cache.freescale.com/files/analog/doc/fact_sheet/PFSeriesFS.pdf
AN4622	Layout Application Note	http://cache.freescale.com/files/analog/doc/app_note/AN4622.pdf
	Product Summary Page	http://www.freescale.com/MMPF0100
Development Tools		
KITPF0100SKTEVBE	PF Programming Socket	http://www.freescale.com/webapp/sps/site/prod_summary.jsp?code=KITPF0100SKTEVBE
KITPFGUI 4.0	KITPFGUI 4.0 Graphical User Interface	http://www.freescale.com/webapp/sps/download/license.jsp?colCode=KITPFGUI_4.0.ZIP
Other		
	Power Management Home Page	http://www.freescale.com/PMIC
	Analog Home Page	http://www.freescale.com/analog

7.1 Support

Visit Freescale.com/support for a list of phone numbers within your region.

7.2 Warranty

Visit Freescale.com/warranty for a list of phone numbers within your region.

8 Revision History

Revision	Date	Description of Changes
1.0	12/2013	• Initial Release



How to Reach Us:

Home Page:
freescale.com

Web Support:
freescale.com/support

Information in this document is provided solely to enable system and software implementers to use Freescale products. There are no express or implied copyright licenses granted hereunder to design or fabricate any integrated circuits based on the information in this document.

Freescale reserves the right to make changes without further notice to any products herein. Freescale makes no warranty, representation, or guarantee regarding the suitability of its products for any particular purpose, nor does Freescale assume any liability arising out of the application or use of any product or circuit, and specifically disclaims any and all liability, including without limitation consequential or incidental damages. "Typical" parameters that may be provided in Freescale data sheets and/or specifications can and do vary in different applications, and actual performance may vary over time. All operating parameters, including "typicals," must be validated for each customer application by customer's technical experts. Freescale does not convey any license under its patent rights nor the rights of others. Freescale sells products pursuant to standard terms and conditions of sale, which can be found at the following address: freescale.com/SalesTermsandConditions.

Freescale and the Freescale logo are trademarks of Freescale Semiconductor, Inc., Reg. U.S. Pat. & Tm. Off. SMARTMOS is a trademark of Freescale Semiconductor, Inc. All other product or service names are the property of their respective owners.

© 2013 Freescale Semiconductor, Inc.

Document Number: KTPFPGHWUG
Rev. 1.0
12/2013

