

## Description

The AP3301 is a peak-current control, Quasi-Resonant (QR) PWM controller which is optimized for high performance, low standby power and cost effective offline flyback converters.

At no load or light load, the IC will enter the burst mode to minimize standby power consumption. The minimum switching frequency (about 20kHz) is set to avoid the audible noise. At medium load, the IC will enter valley lock QR mode with frequency foldback to improve system efficiency and EMI performance. The maximum switching frequency (about 120kHz) is set to clamp the QR frequency to improve efficiency. At low line input & heavy load, when switching frequency decreases below 62kHz with output load increasing, the IC will enter CCM mode with fixed switching frequency of 62kHz to optimize low line power conversion efficiency. Furthermore, the frequency dithering function is built in to reduce EMI emission.

Internal slope compensation allows more stable peak-current mode control over wide range of input voltage and load conditions. Internal piecewise linear line compensation ensures constant output power limit over entire universal line voltage range.

Comprehensive protection features are included, such as brown out protection, cycle-by-cycle current limit (OCP), VCC Over Voltage Protection (VOVP), Secondary-Side Output OVP (SOVP), internal OTP, Over Load Protection (OLP) and pins' fault protection.

## Features

- Very Low Start-up Current
- Multi-Mode Control
- Quasi-Resonant Operation with Valley Lock
- Fixed Frequency CCM Operation at Low Line Heavy Load
- Non-Audible-Noise Quasi-Resonant Control
- Internal Slope Compensation
- Soft Start During Startup Process
- Frequency Fold Back for High Average Efficiency
- Secondary Winding Short Protection with FOCP
- Frequency dithering for Reducing EMI
- VCC Maintain Mode
- Useful Pin Fault Protection:
  - SENSE Pin Floating
  - FB/Opto-coupler Open/Short
- Comprehensive System Protection Feature:
  - VCC Over Voltage Protection (VOVP)
  - Over Load Protection (OLP)
- Brown Out Protection (BNO)
- Secondary Side OVP (SOVP)
- Mini Size Package of SOT26
- **Totally Lead-free & Fully RoHS Compliant (Notes 1 & 2)**
- **Halogen and Antimony Free. "Green" Device (Note 3)**

Notes:

1. No purposely added lead. Fully EU Directive 2002/95/EC (RoHS) & 2011/65/EU (RoHS 2) compliant.
2. See [http://www.diodes.com/quality/lead\\_free.html](http://www.diodes.com/quality/lead_free.html) for more information about Diodes Incorporated's definitions of Halogen- and Antimony-free, "Green" and Lead-free.
3. Halogen- and Antimony-free "Green" products are defined as those which contain <900ppm bromine, <900ppm chlorine (<1500ppm total Br + Cl) and <1000ppm antimony compounds.

## Pin Assignments

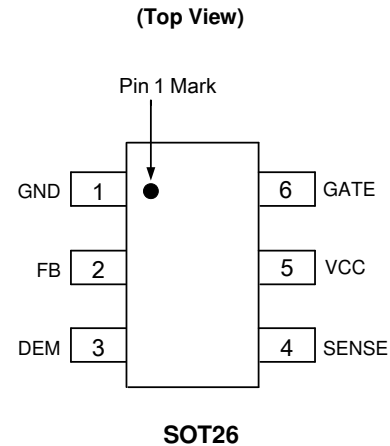

## Applications

- Switching AC-DC Adapter/Charger
- ATX/BTX Auxiliary Power
- Set-Top Box (STB) Power Supply
- Open Frame Switching Power Supply

**Typical Applications Circuit**

NEW PRODUCT

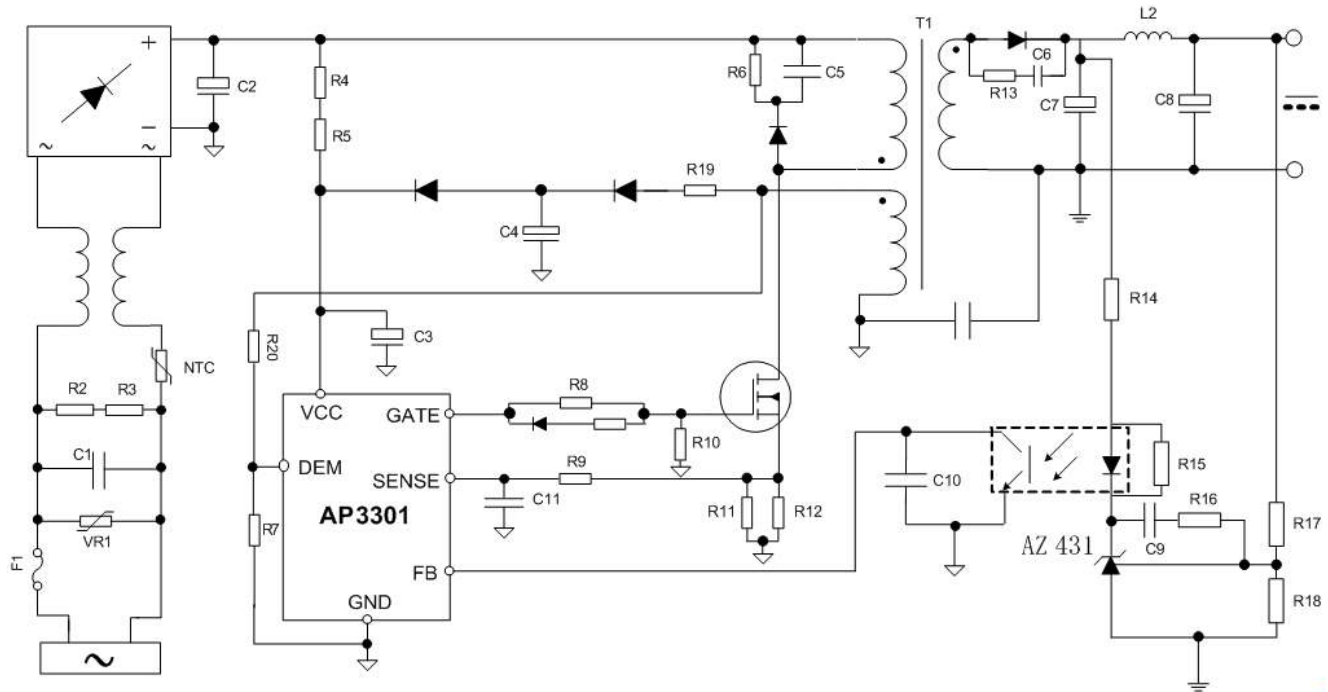

**Pin Descriptions**

Pin Number	Pin Name	Function
1	GND	Signal ground. Current return for driver and control circuits
2	FB	Feedback. Directly connected to the opto-coupler
3	DEM	Valley detection for QR control, AC line voltage detection for Brown-in/Brown-out trigger current and SOVP
4	SENSE	Current Sense
5	VCC	Supply voltage of driver and control circuits
6	GATE	Gate driver output

**Functional Block Diagram**

NEW PRODUCT

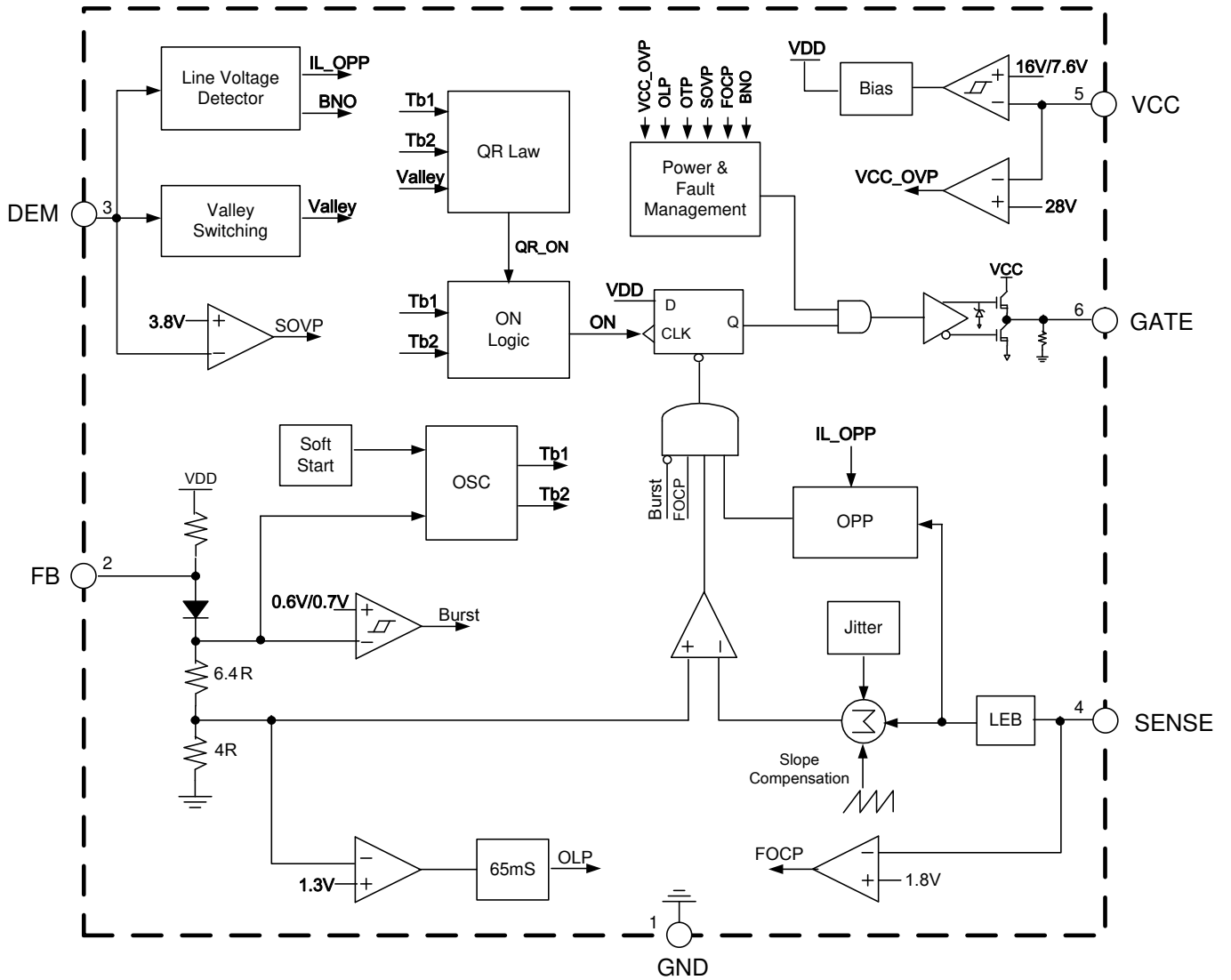

### Absolute Maximum Ratings (Note 4)

Symbol	Parameter	Rating	Unit
$V_{CC}$	Power Supply Voltage	30	V
$I_O$	Gate Output Current	350	mA
$V_{FB}, V_{SENSE}, V_{DEM}$	Input Voltage to FB, SENSE, DEM	-0.3 to 7	V
$\theta_{JA}$	Thermal Resistance (Junction to Ambient)	250	°C/W
$P_D$	Power Dissipation at $T_A < +25^\circ\text{C}$	500	mW
$T_J$	Operating Junction Temperature	-40 to +150	°C
$T_{STG}$	Storage Temperature Range	+150	°C
-	ESD (Human Body Model)	3000	V
-	ESD (Machine Model)	200	V

Note 4: Stresses greater than those listed under "Absolute Maximum Ratings" may cause permanent damage to the device. These are stress ratings only, and functional operation of the device at these or any other conditions beyond those indicated under "Recommended Operating Conditions" is not implied. Exposure to "Absolute Maximum Ratings" for extended periods may affect device reliability.

### Recommended Operating Conditions

Symbol	Parameter	Min	Max	Unit
$V_{CC}$	Supply Voltage	10	25	V
$T_A$	Ambient Temperature	-40	+85	°C

**Electrical Characteristics** (@T<sub>A</sub> = -40 to +85°C, V<sub>CC</sub> = 18V, unless otherwise specified.)

Symbol	Parameter	Conditions	Min	Typ	Max	Unit
<b>Supply Voltage (VCC Pin)</b>						
I <sub>ST</sub>	Startup Current	–	–	1	5	μA
I <sub>CC</sub>	Operating Supply Current	V <sub>FB</sub> =4V, C <sub>L</sub> =0nF (Note 5)	1.5	1.8	2	mA
I <sub>CC-FAULT</sub>	Operating Current If Fault Occurs	V <sub>FB</sub> =4V, V <sub>CS</sub> =0V (Note 5)	0.15	0.3	0.45	mA
V <sub>ST</sub>	Startup Voltage	–	14.5	15.8	16.5	V
V <sub>M</sub>	V <sub>CC</sub> Maintain	–	9.0	9.4	9.8	V
V <sub>UVLO</sub>	Shutdown Voltage	–	7.1	7.6	8.1	V
V <sub>CC-OVP</sub>	V <sub>CC</sub> OVP	–	27	28.5	30	V
<b>PWM Section/Oscillator Section</b>						
f <sub>OSC-CCM</sub>	CCM Oscillation Frequency	–	57	62	67	kHz
f <sub>OSC-MAXC</sub>	Maximum Clamp Frequency	–	110	120	130	kHz
f <sub>OSC-GREEN</sub>	Green Mode Frequency	–	18	–	25	kHz
f <sub>OSC-JITTER</sub>	Frequency Dithering	CCM (Note 6)	–	±8	±12	%
<b>Current Sense Section (SENSE Pin)</b>						
V <sub>CS-MAX</sub>	Maximum SENSE Voltage	I <sub>DEM_SOURCE</sub> =150μA	0.8	0.88	0.96	V
V <sub>TH-FOCP</sub>	FOCP Voltage	–	1.6	1.8	2.0	V
t <sub>DELAY-FOCP</sub>	FOCP Debounce Time (Note 6)	–	–	6	–	Cycles
t <sub>LEB</sub>	LEB Time of SENSE	–	150	250	350	ns
t <sub>DELAY-CS</sub>	Delay to Output (Note 6)	–	–	150	–	ns
<b>Feedback Input Section (FB Pin)</b>						
K <sub>FB-CS</sub>	The Ratio of Input Voltage to Current Sense Voltage	–	–	3	–	V/V
R <sub>FB</sub>	Input Impedance	–	15	20	25	kΩ
I <sub>FB-SOURCE</sub>	Source Current	V <sub>FB</sub> =0V	0.15	0.25	0.35	mA
V <sub>FB-GREEN</sub>	The Threshold Enter QR Mode	–	–	3	–	V
G <sub>QR</sub>	QR Mode Frequency Modulation Slope Versus V <sub>FB</sub>	–	–	140	–	kHz/V
V <sub>BURST</sub>	Input Voltage for Zero Duty	–	1.35	1.55	1.75	V
V <sub>FB-OLP</sub>	Over Load Protection	–	–	4.5	–	V
t <sub>ON-MAX</sub>	Maximum On Time	–	11	13	16	μs
t <sub>SOFT-ST</sub>	Soft-Start Time	–	–	5	–	ms
t <sub>DELAY-OLP</sub>	Delay of Over Load Protection	–	–	70	–	ms

**Electrical Characteristics** (Cont.) (@ $T_A$  = -40 to +85°C,  $V_{CC}$  = 18V, unless otherwise specified.)

Symbol	Parameter	Conditions	Min	Typ	Max	Unit
<b>Output Section (GATE Pin)</b>						
$V_{GATE-L}$	Output Low Level	$I_O=20mA, V_{CC}=12V$	–	–	1	V
$V_{GATE-H}$	Output High Level	$I_O=20mA, V_{CC}=12V$	8	–	–	V
$V_{GATE-CLP}$	Output Clamping Voltage	–	11	13	15	V
$t_{GATE-RISE}$	Rising Time (Note 6)	$C_L=1nF, V_{CC}=13V$	–	140	200	ns
$t_{GATE-FALL}$	Falling Time (Note 6)	$C_L=1nF, V_{CC}=13V$	–	50	100	ns
<b>Demagnetization Section (DEM Pin)</b>						
$V_{TH-DEM}$	De-Magnetization Voltage	–	–	75	–	mV
$I_{BNI}$	Brown In Reference	–	80	85	90	$\mu A$
$I_{BNO}$	Brown Out Reference	–	72	79	84	$\mu A$
$V_{TH-SOVP}$	SOVP Threshold	–	3.5	3.8	4.1	V
$t_{SAMPLE}$	Sample Delay Time (Note 6)	–	–	2.5	–	$\mu s$
<b>Delay Time Section</b>						
$t_{DELAY-BNO}$	Brown Out Debounce Time	–	–	50	–	ms
$t_{DELAY-LATCH}$	Delay of Latch Protection (Note 6)	SOVP, $V_{CC}$ OVP	–	6	–	Cycles
<b>Internal OTP Section</b>						
OTP	OTP Enter (Note 6)	–	–	+150	–	°C
THYS	OTP Exit (Note 6)	–	–	+125	–	°C

Notes: 5. Data measured in IC test mode.  
6. Guaranteed by design.

**Performance Characteristics**

NEW PRODUCT

**Startup Voltage vs. Ambient Temperature**

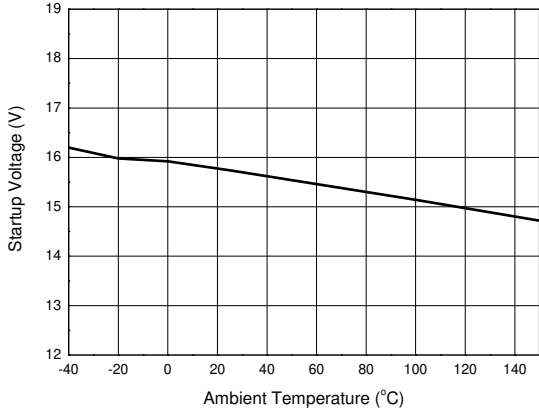

**Shutdown Voltage vs. Ambient Temperature**

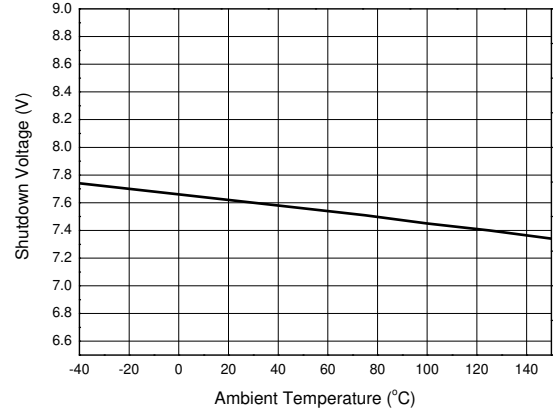

**Startup Current vs. Ambient Temperature**

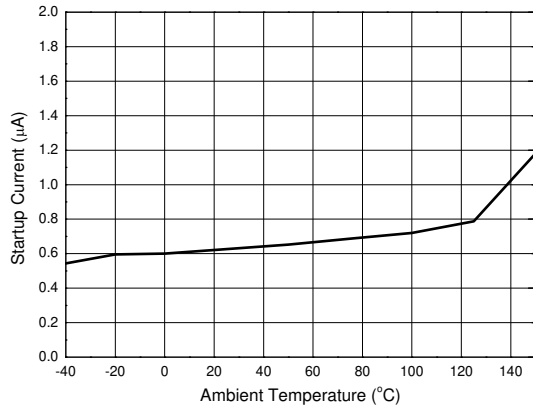

**Operating Current vs. Ambient Temperature**

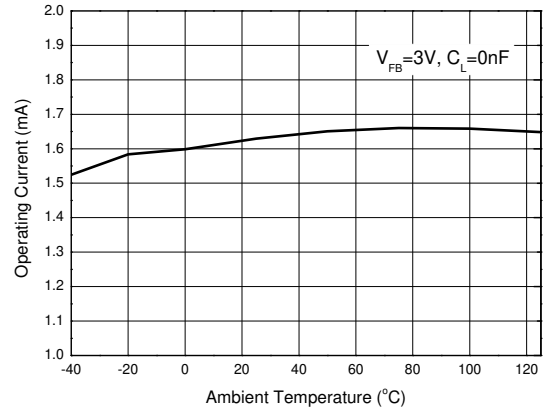

**CCM Frequency vs. Ambient Temperature**

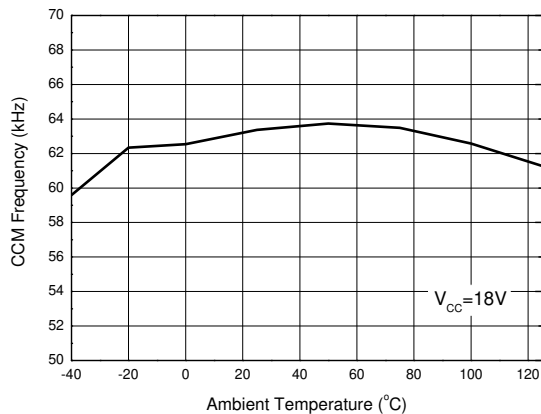

**CCM Frequency vs. V<sub>CC</sub>**

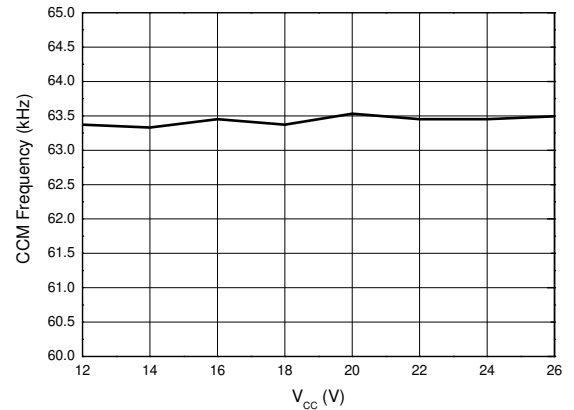

**Performance Characteristics (Cont.)**

**V<sub>CC</sub> OVP vs. Ambient Temperature**

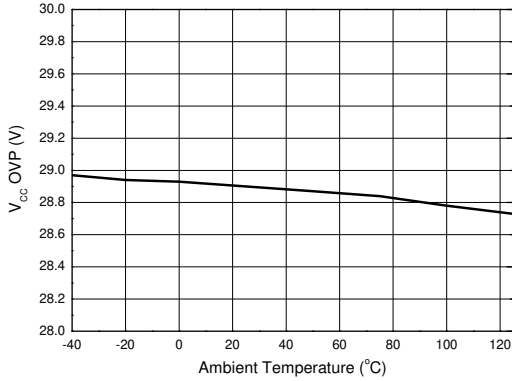

**Green Mode Frequency vs. Ambient Temperature**

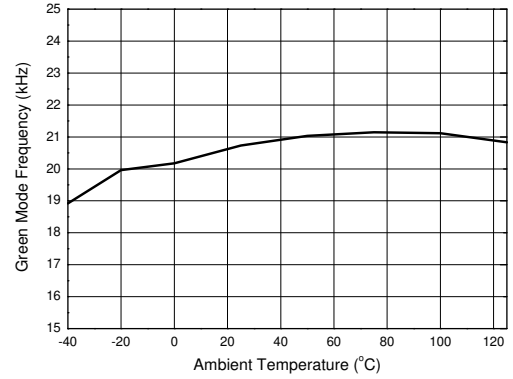

**Maximum Clamp Frequency vs. Ambient Temperature**

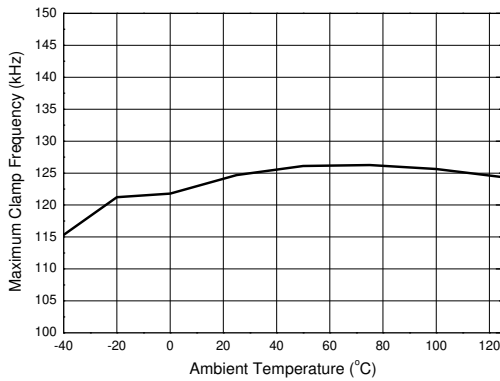

**FB Pin Input Impedance vs. Ambient Temperature**

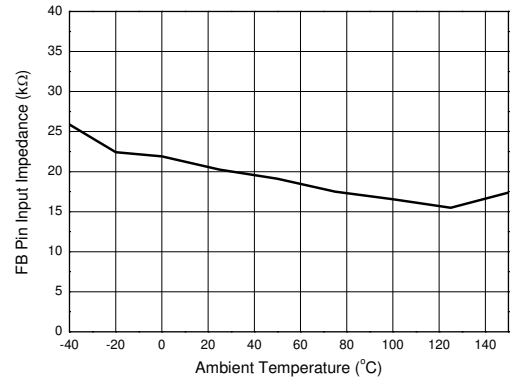

**V<sub>BURST</sub> vs. Ambient Temperature**

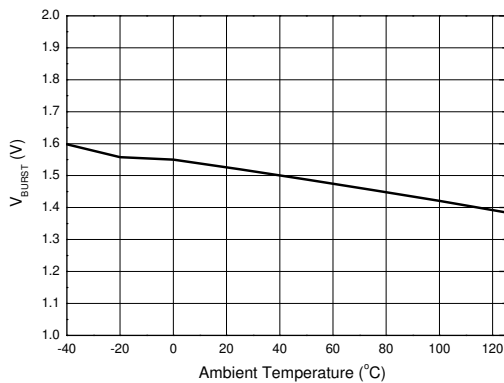

**I<sub>BN1</sub> vs. Ambient Temperature**

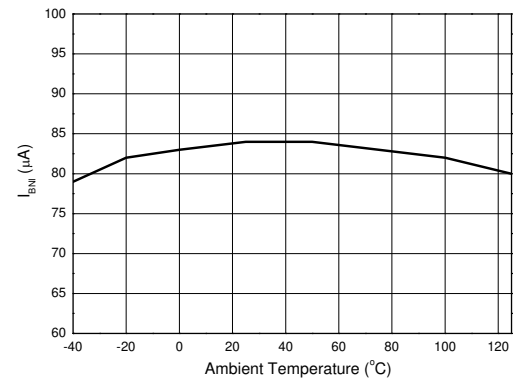

NEW PRODUCT



**Performance Characteristics (Cont.)**

**I<sub>BNO</sub> vs. Ambient Temperature**

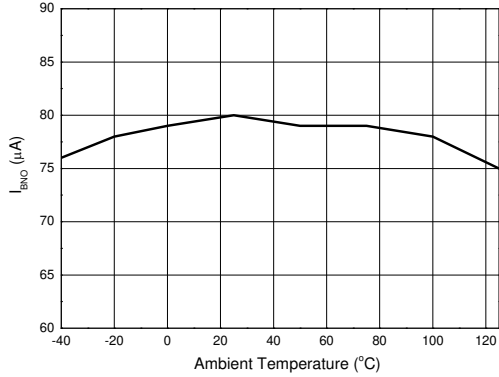

**V<sub>M</sub> vs. Ambient Temperature**

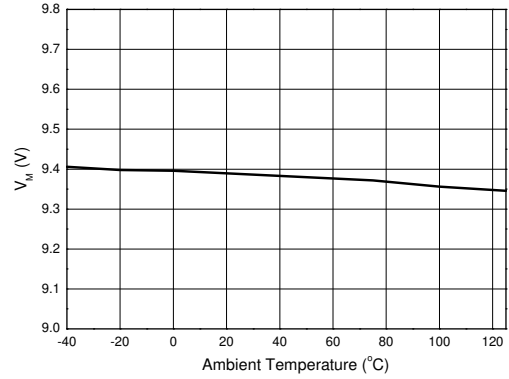

**PIN3 Utilization for BNO/SOVP/OCP COMP**

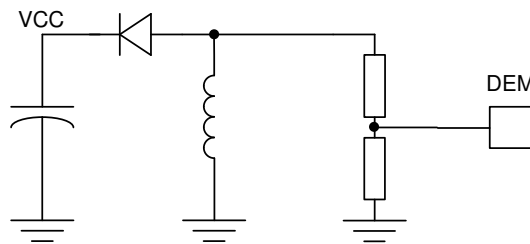

**SOVP/IBNI/IBNO**

**Operation Description**

The AP3301 realizes Multi-Mode Operation including Burst mode, QR mode and CCM mode, which is specifically designed for off-line AC-DC power supply used in LCD monitor, notebook adapter and battery charger applications. At medium load, the IC will enter valley lock QR mode with frequency foldback to improve system efficiency and EMI performance. It offers a cost effective solution with a versatile protection function.

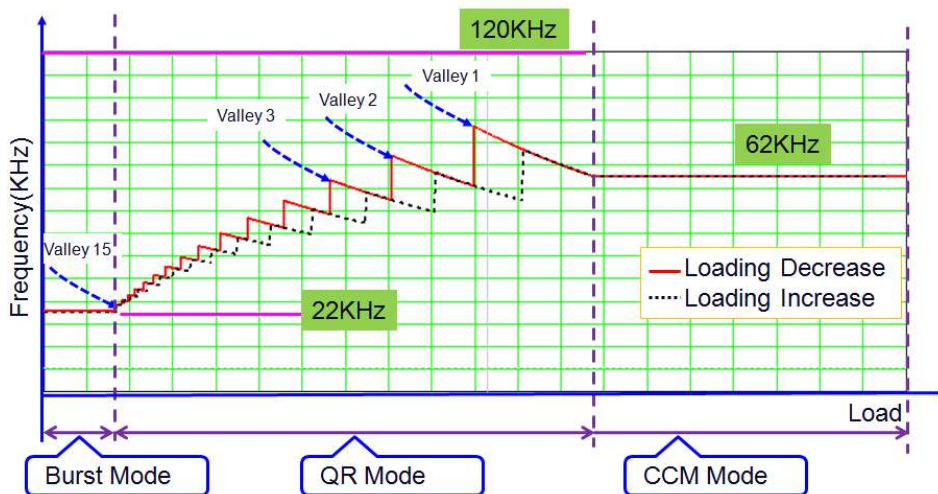

Figure 1

## Operation Description (Cont.)

### Multi-Mode Operation

The switching frequency curve in Figure 1 shows three operation modes.

- Burst Mode**  
 At no load and light load, the system will operate at burst mode. In burst mode, the switching frequency is fixed at about 22kHz to avoid audible noise. When the FB voltage is lower than 1.55V, the controller will not provide driving signal and the FB voltage will rise above 1.65V, then the driving signal will resume. By this control strategy, the system will eliminate a bunch of pulses and the power loss is reduced.
- QR Mode**  
 QR is the abbreviation of Quasi-Resonant which means that the power MOSFET is forced to turn on at valleys of  $V_{DS}$ . With QR control, the switching power loss will be reduced by lower voltage stress of MOSFET. The  $V_{DS}$  valley is detected by DEM pin through the voltage divider network of  $R_{DEM}$  and  $R_{SOVP}$ , once the divided voltage is less than 75mV during turning off internal of MOSFET, the counter in AP3301 will count it as one valley. At light load and medium load, the system will enter QR mode. As the load changes, the trend of the switching frequency in QR mode is modulated by AP3301 and following the internal arithmetic it is increased or decreased. In general when the turning-on valley changes, the frequency will jump to a new value, this frequency jump transits quickly and the turning-on valley changes between two neighboring valleys back and forth, this unstable condition introduces unacceptable audible noise. In benefit of Diodes proprietary "Valley Lock" technology, the turning on valley is locked and will not switch iteratively when the load is changed. Meanwhile, the frequency dithering function is built in to reduce EMI emission. As Figure 2 shows, switching frequencies between the power increase and power decrease line are a little different because of the inherent characteristic of valley-lock QR control, and it will result in a tiny difference in efficiency. When the load increases, the switching frequency is also increased, a frequency of 120kHz is set to clamp the maximum operating frequency, if this 120kHz is touched, the system will operate in normal DCM mode, and will return to QR if the load continues to increase.
- CCM Mode**  
 With the load increases, if the switching frequency decreases below 62kHz in valley1 mode, CCM mode is implemented to achieve high efficiency. Usually at low line voltage, the system will enter CCM mode at heavy load, while high line voltage the system may still operate at QR mode with 1st or 2nd valley on.

### Start-up Current and UVLO

The start-up current of AP3301 is optimized to realize ultra low current (1 $\mu$ A typical) so that VCC capacitor can be charged more quickly. The direct benefit of low start-up current is the availability of using large start-up resistor, which minimizes the resistor power loss for high voltage AC input.

An UVLO comparator is included in AP3301 to detect the voltage on VCC pin. It ensures that AP3301 can draw adequate energy from hold-up capacitor during power-on. The turn-on threshold is 15.8V and the turn-off threshold is 7.6V.

### Current Sense Comparator and PWM Latch

The AP3301 operates as a current mode controller, the output switch conduction is initiated by every oscillator cycle and is terminated when the peak inductor current reaches the threshold level established by the FB pin. The inductor current signal is converted to a voltage signal by inserting a reference sense resistor  $R_S$ . The inductor current under normal operating conditions is controlled by the voltage at FB pin. The relation between peak inductor current ( $I_{PK}$ ) and  $V_{FB}$  is:

$$I_{PK} = (V_{FB} - 1.0) / 3R_S$$

Moreover, FOCF with 1.8V threshold is only about  $t_{DELAY-FOCF}$  delay, which can avoid some catastrophic damages such as secondary rectifier short test. Few drive cycles can alleviate the destruction range and get better protection.

### Leading-edge Blanking

A narrow spike on the leading edge of the current waveform can usually be observed when the power MOSFET is turned on. A  $t_{LEB}$  time leading-edge blank is built-in to prevent the false-triggering caused by the turn-on spike. During this period, the current limit comparator is disabled and the gate driver cannot be switched off.

At the time of turning off the MOSFET, a negative undershoot (maybe larger than -0.3V) can occur on the SENSE pin. So it is strongly recommended to add a small RC filter or at least connect a resistor "R" on this pin to protect the IC (Shown as Figure 2).

**Operation Description (Cont.)**

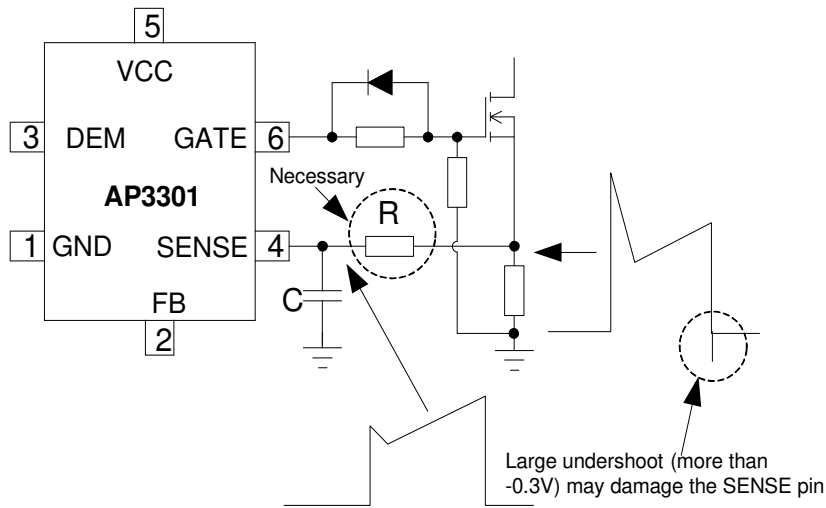

Figure 2

**Built-in Slope Compensation**

It is well known that a continuous current mode SMPS may become unstable when the duty cycle exceeds 50%. The built-in slope compensation can improve the stability, so there is no need for design engineer to spend much time on that.

**FB Pin and Short Circuit Protection**

This pin is normally connected to the opto-coupler and always paralleled with a capacitor for loop compensation. When the voltage at this pin is greater than  $V_{FB-OLP}$  and lasts for about  $t_{DELAY-OLP}$ , the IC will enter the protection mode. For AP3301, the system will enter hiccup mode to wait the  $V_{CC}$  decreasing to low UVLO level, then the IC will try to restart until the failure removed. And when this voltage is less than 1.55V, the IC will stop the drive pulse immediately. Therefore, this feature can be used for short circuit protection, which makes the system immune from damage. Normally, output short makes the  $V_{FB}$  value to the maximum because the opto-coupler is cut off.

When  $V_{CC}$  decreases to a setting threshold, the  $V_{CC}$  maintain comparator will output some drive signal to make the system switch and provide a proper energy to  $V_{CC}$  pin. The  $V_{CC}$  maintain function will cooperate with the PWM and burst mode loop which can make the output voltage variation be within the regulation. This mode is very useful for reducing startup resistor loss and achieving a better standby performance with a low value  $V_{CC}$  capacitor. The  $V_{CC}$  is not easy to touch the shutdown threshold during the startup process and step load. This will also simplify the system design. The minimum  $V_{CC}$  voltage is suggested to be designed a little higher than  $V_{CC}$  maintain threshold thus can achieve the best balance between the standby and step load performance.

**Brown-in/Brown-out**

During turning-on interval of primary power MOSFET, the DEM pin is clamped to GND, the current flows through  $R_{DEM}$  and pin DEM reflecting the rectified value of AC line voltage as showed as Figure 3, this current multiplies with  $R_{BNO}$  represents the sample voltage of AC line voltage, take the peak value of the sample voltage to compare with the internal fixed threshold.

When the AC source is on, the IC will send several drive signals to confirm that the DEM pin current is higher than  $I_{BNI}$  during primary MOSFET turning on time, then AP3301 starts to provide drive signal, and if the current decreases below  $I_{BNO}$  for about 50ms, AP3301 enters brown out protection and no drive pulse output, a new startup will not begin until the sampled signal is lower than  $I_{BNI}$  again and  $V_{CC}$  is higher than  $V_{UVLO}$  threshold.

**Operation Description (Cont.)**

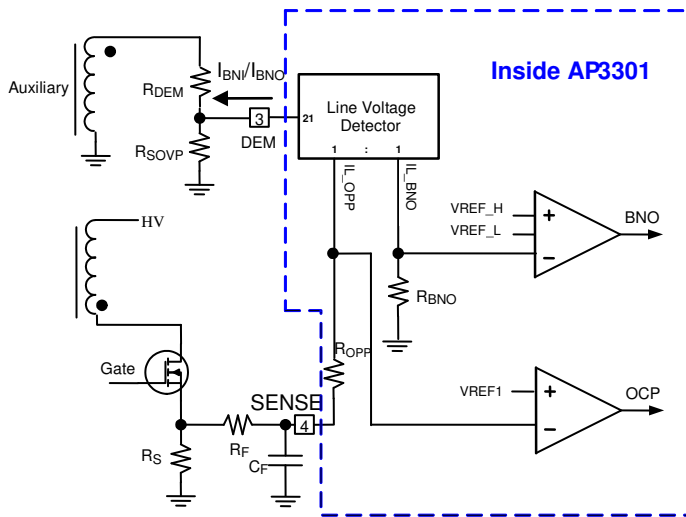

Figure 3

**SOVP Protection Function**

For some applications, the system requires the output over voltage protection function. The DEM pin compares the divided voltage from the VCC winding with the inner threshold, when the voltage between R<sub>DEM</sub> and R<sub>SOVP</sub> is higher than V<sub>TH-SOVP</sub> during primary power MOSFET turning off duration, AP3301 will trigger SOVP function and the system will enter the latch protection mode. Since the value of VCC winding's waveform reflects the output voltage precisely, the Secondary Output Voltage Protection (SOVP) can be achieved by this function.

**Other System Protection and Pin Fault Protection**

The AP3301 provides versatile system and pin fault protections. The OCP comparator realizes the cycle-by-cycle current limiting (OCP). In universal input line voltage, the IC realizes the constant over load protection (OLP). VCC over voltage protection can be applied as the primary OVP or opto-coupler broken protection. The AP3301 also has pin fault connection protection including floating and short connection. The floating pin protection includes the SENSE, FB, etc. The short pin protection includes the DEM pin short protection. When these pins are floated or DEM pin is shorted to ground, PWM switching will be disabled, thus protecting the power system.

**Internal OTP Protection Function**

The AP3301 integrates an internal temperature sensor. It has a trigger window of entering OTP mode at +150°C and exiting at +125°C. The internal OTP protection mode is auto-recovery mode.

**Ordering Information**

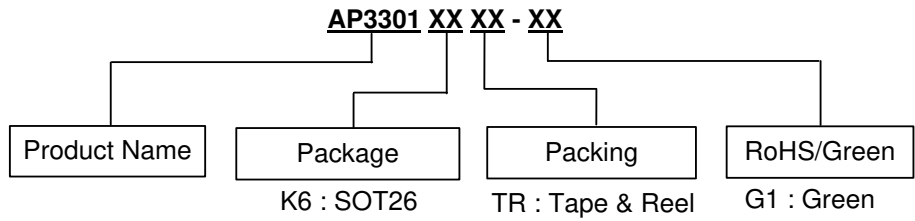

Package	Part Number	Marking ID	Packing
SOT26	AP3301K6TR-G1	GTC	3000/Tape & Reel

**Marking Information**

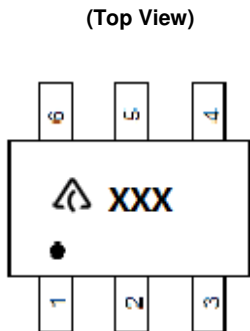

 : Logo  
 XXX: Marking ID (See Ordering Information)

**Package Outline Dimensions** (All dimensions in mm(inch).)

(1) Package Type: SOT26

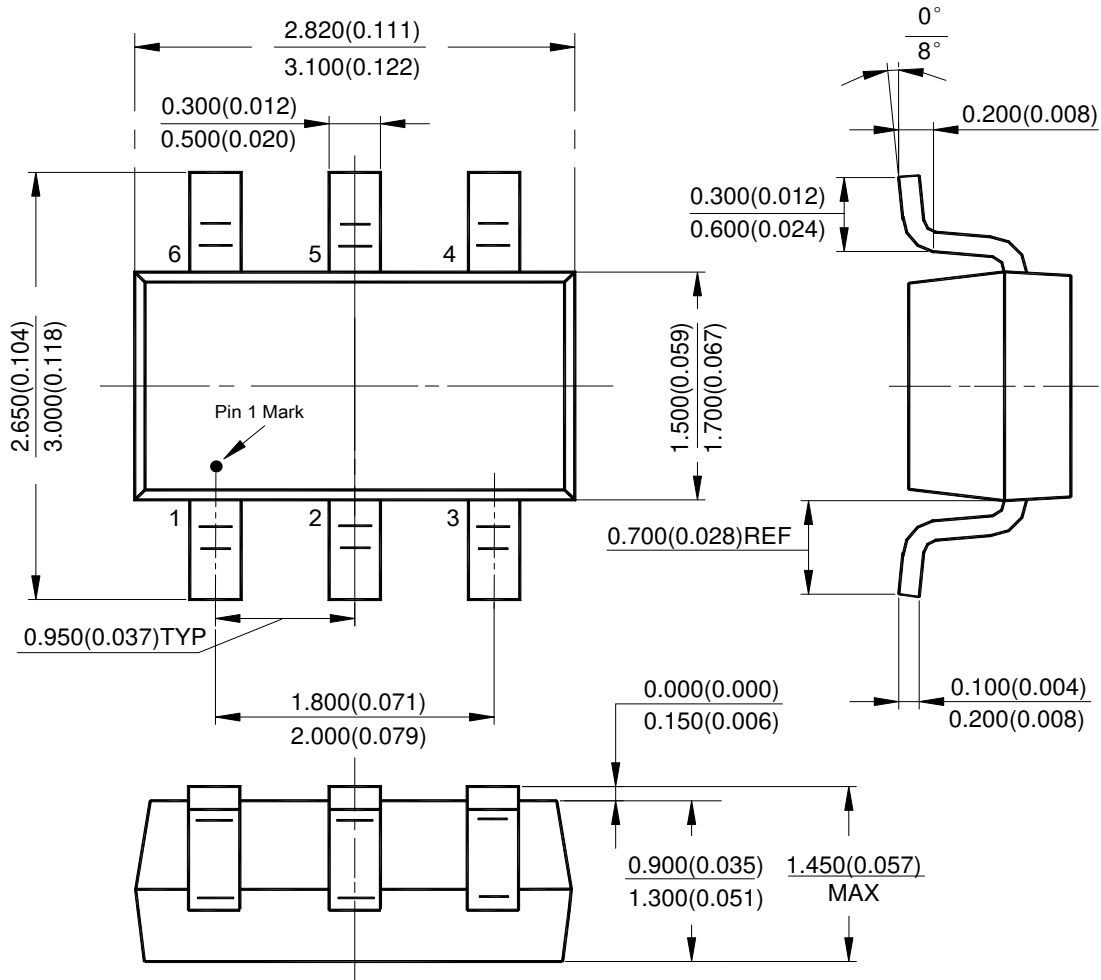

NEW PRODUCT

**Suggested Pad Layout**

(1) Package Type: SOT26

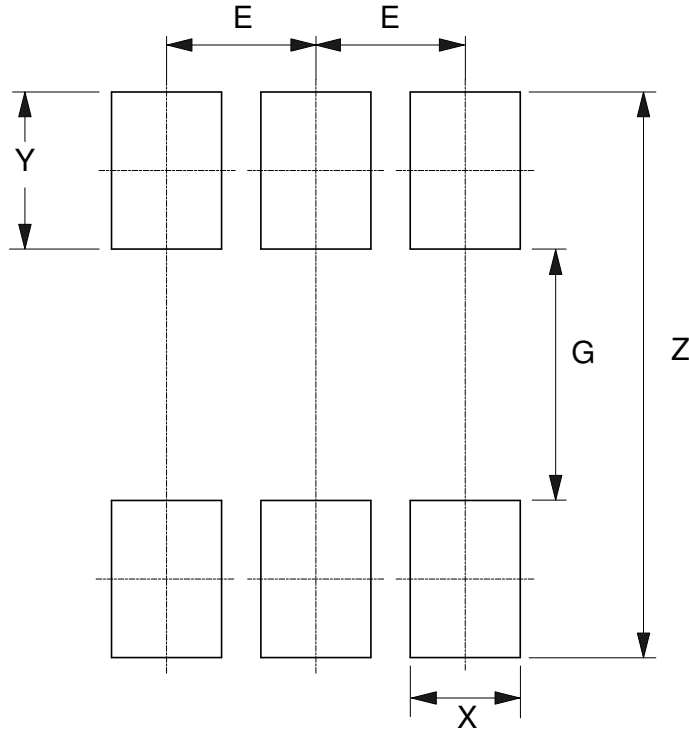

Dimensions	Z (mm)/(inch)	G (mm)/(inch)	X (mm)/(inch)	Y (mm)/(inch)	E (mm)/(inch)
Value	3.600/0.142	1.600/0.063	0.700/0.028	1.000/0.039	0.950/0.037

**IMPORTANT NOTICE**

DIODES INCORPORATED MAKES NO WARRANTY OF ANY KIND, EXPRESS OR IMPLIED, WITH REGARDS TO THIS DOCUMENT, INCLUDING, BUT NOT LIMITED TO, THE IMPLIED WARRANTIES OF MERCHANTABILITY AND FITNESS FOR A PARTICULAR PURPOSE (AND THEIR EQUIVALENTS UNDER THE LAWS OF ANY JURISDICTION).

Diodes Incorporated and its subsidiaries reserve the right to make modifications, enhancements, improvements, corrections or other changes without further notice to this document and any product described herein. Diodes Incorporated does not assume any liability arising out of the application or use of this document or any product described herein; neither does Diodes Incorporated convey any license under its patent or trademark rights, nor the rights of others. Any Customer or user of this document or products described herein in such applications shall assume all risks of such use and will agree to hold Diodes Incorporated and all the companies whose products are represented on Diodes Incorporated website, harmless against all damages.

Diodes Incorporated does not warrant or accept any liability whatsoever in respect of any products purchased through unauthorized sales channel. Should Customers purchase or use Diodes Incorporated products for any unintended or unauthorized application, Customers shall indemnify and hold Diodes Incorporated and its representatives harmless against all claims, damages, expenses, and attorney fees arising out of, directly or indirectly, any claim of personal injury or death associated with such unintended or unauthorized application.

Products described herein may be covered by one or more United States, international or foreign patents pending. Product names and markings noted herein may also be covered by one or more United States, international or foreign trademarks.

This document is written in English but may be translated into multiple languages for reference. Only the English version of this document is the final and determinative format released by Diodes Incorporated.

**LIFE SUPPORT**

Diodes Incorporated products are specifically not authorized for use as critical components in life support devices or systems without the express written approval of the Chief Executive Officer of Diodes Incorporated. As used herein:

A. Life support devices or systems are devices or systems which:

1. are intended to implant into the body, or
2. support or sustain life and whose failure to perform when properly used in accordance with instructions for use provided in the labeling can be reasonably expected to result in significant injury to the user.

B. A critical component is any component in a life support device or system whose failure to perform can be reasonably expected to cause the failure of the life support device or to affect its safety or effectiveness.

Customers represent that they have all necessary expertise in the safety and regulatory ramifications of their life support devices or systems, and acknowledge and agree that they are solely responsible for all legal, regulatory and safety-related requirements concerning their products and any use of Diodes Incorporated products in such safety-critical, life support devices or systems, notwithstanding any devices- or systems-related information or support that may be provided by Diodes Incorporated. Further, Customers must fully indemnify Diodes Incorporated and its representatives against any damages arising out of the use of Diodes Incorporated products in such safety-critical, life support devices or systems.

Copyright © 2016, Diodes Incorporated

[www.diodes.com](http://www.diodes.com)