

LOC		DIST		REVISIONS			
GP	00	F	LTW	DESCRIPTION	DATE	DWN	APVD
		E		REV: EC 001C-0007-01	22JAN01	JA	TW
		F		REVISED PER EC 0S15-0450-02	21JAN2003	DLD	RPM
		G		REVISED PER EC 0S15-0324-03	03DEC03	JB	CF

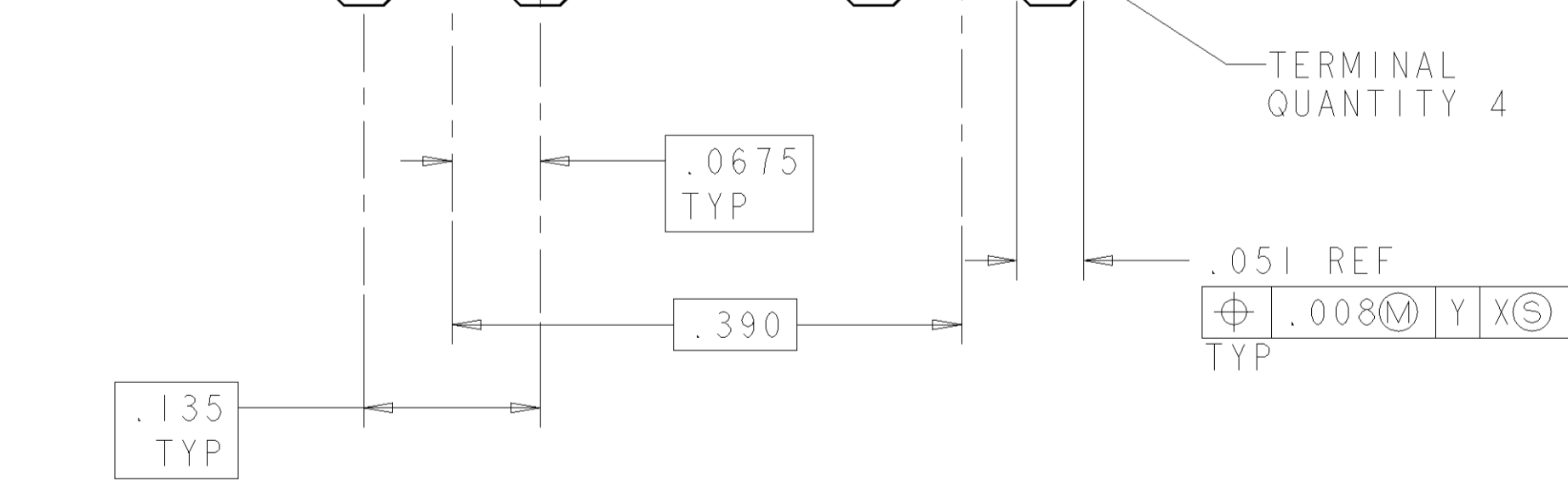

- ⚠ MATERIAL: BASE - HIGH TEMPERATURE MOLDING COMPOUND, BLACK. WIRE STUFFER: - HIGH TEMPERATURE MOLDING COMPOUND. TERMINAL - COPPER ALLOY, PLATED WITH 3.81μm MINIMUM THICK TIN OVER 1.27μm MINIMUM THICK NICKEL UNDERPLATE.
- ⚠ EACH WIRE ENTRY HOLE ACCEPTS ONE UNSTRIPPED SOLID COPPER 22-26 AWG WIRE WITH WIRE INSULATION DIAMETER RANGE FROM .060 THROUGH .040. OTHER WIRE SIZES AND TYPES SHALL BE SUBMITTED TO AMP ENGINEERS FOR APPLICATION APPROVAL.
- 3. SOLDER TABS PROVIDED FOR PERMANENT BOARD MOUNTING.
- ⚠ LOCATION OF HOLE PATTERN DETERMINED BASED ON CUSTOMER REQUIREMENTS.

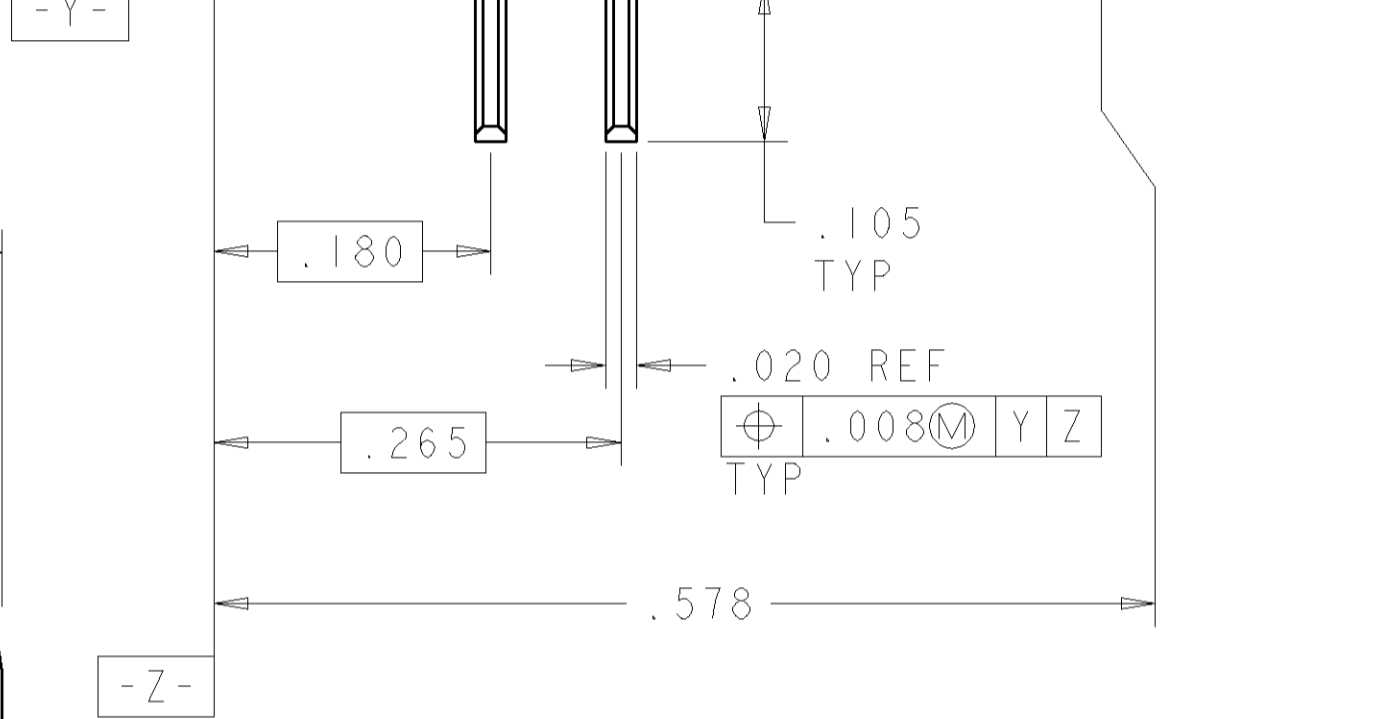
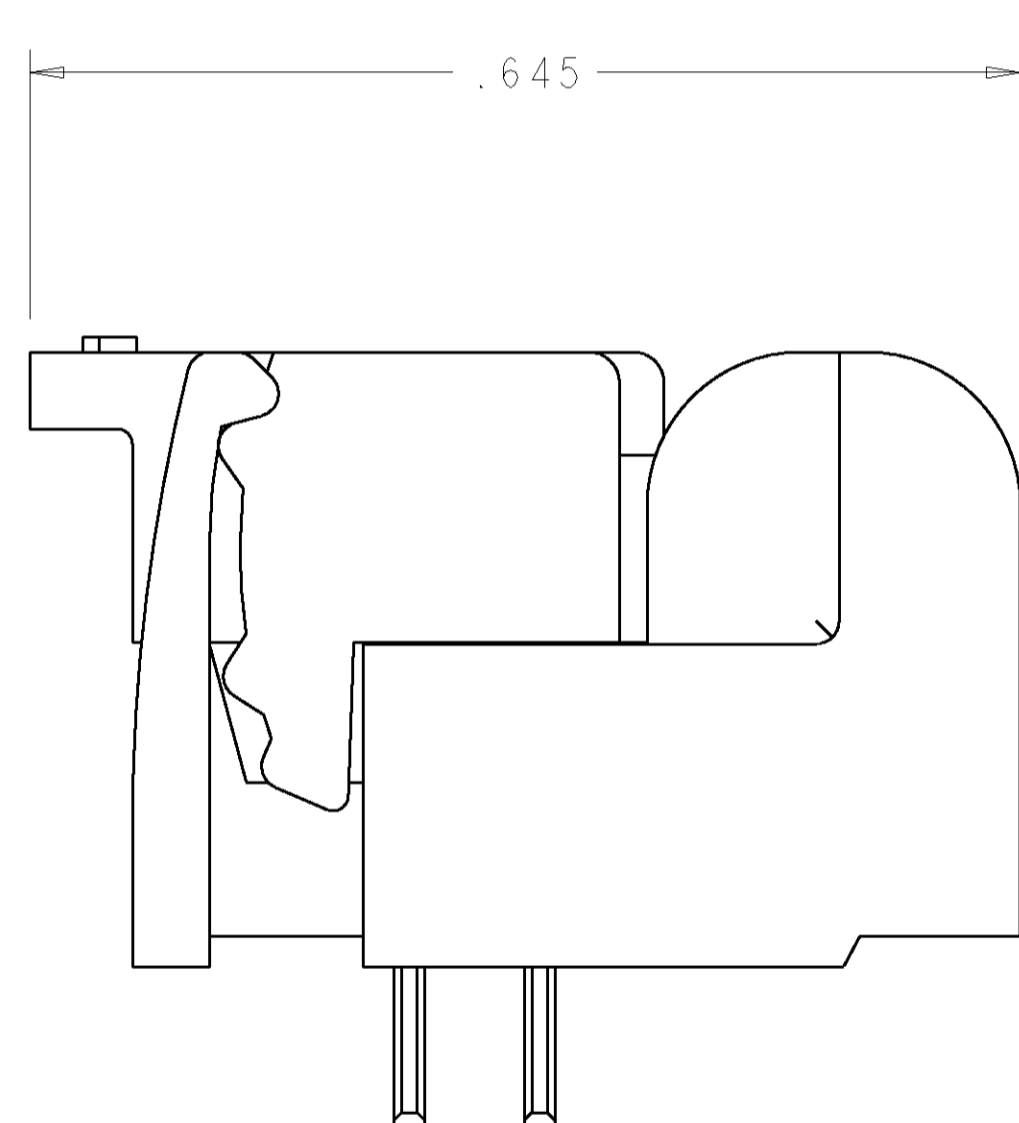
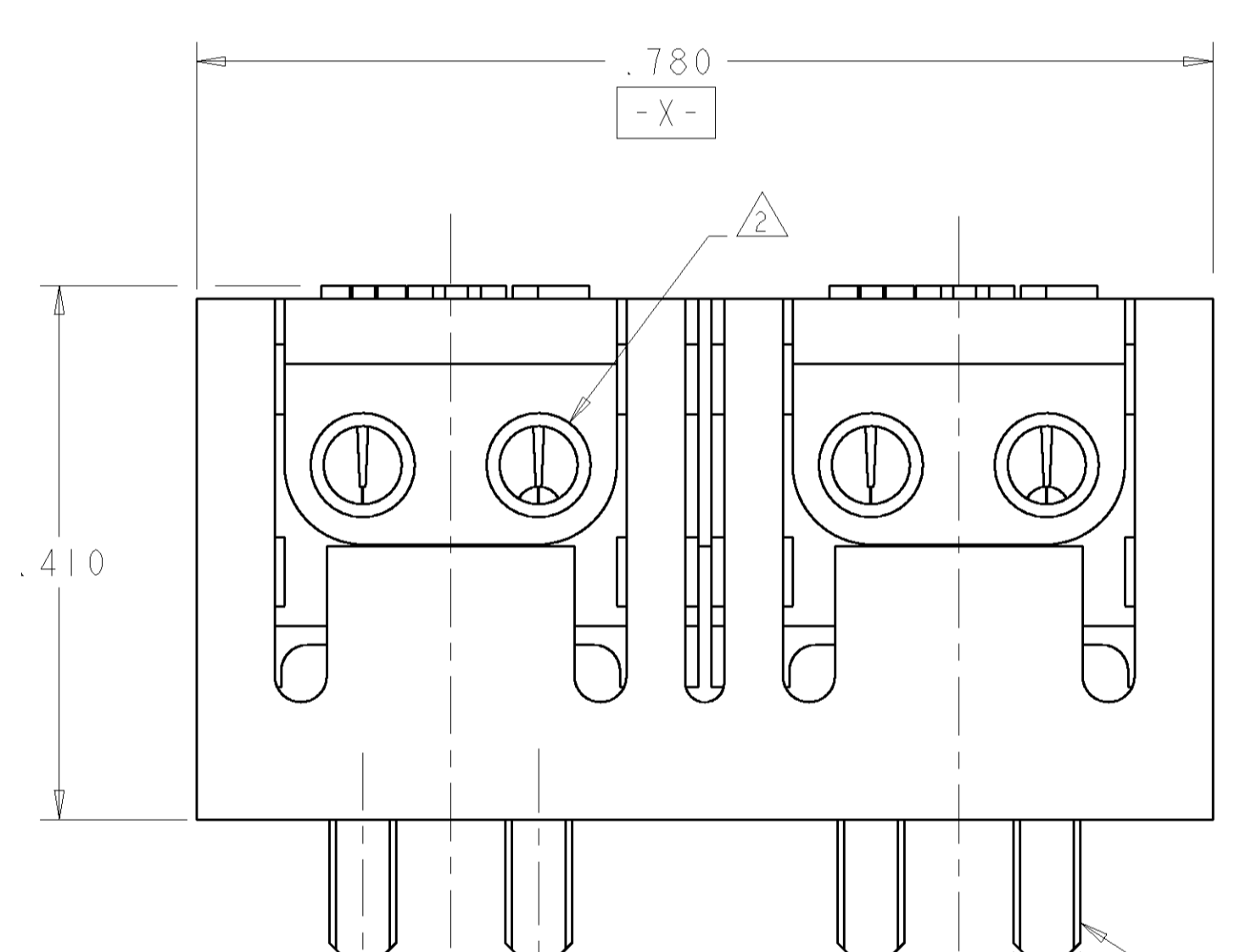
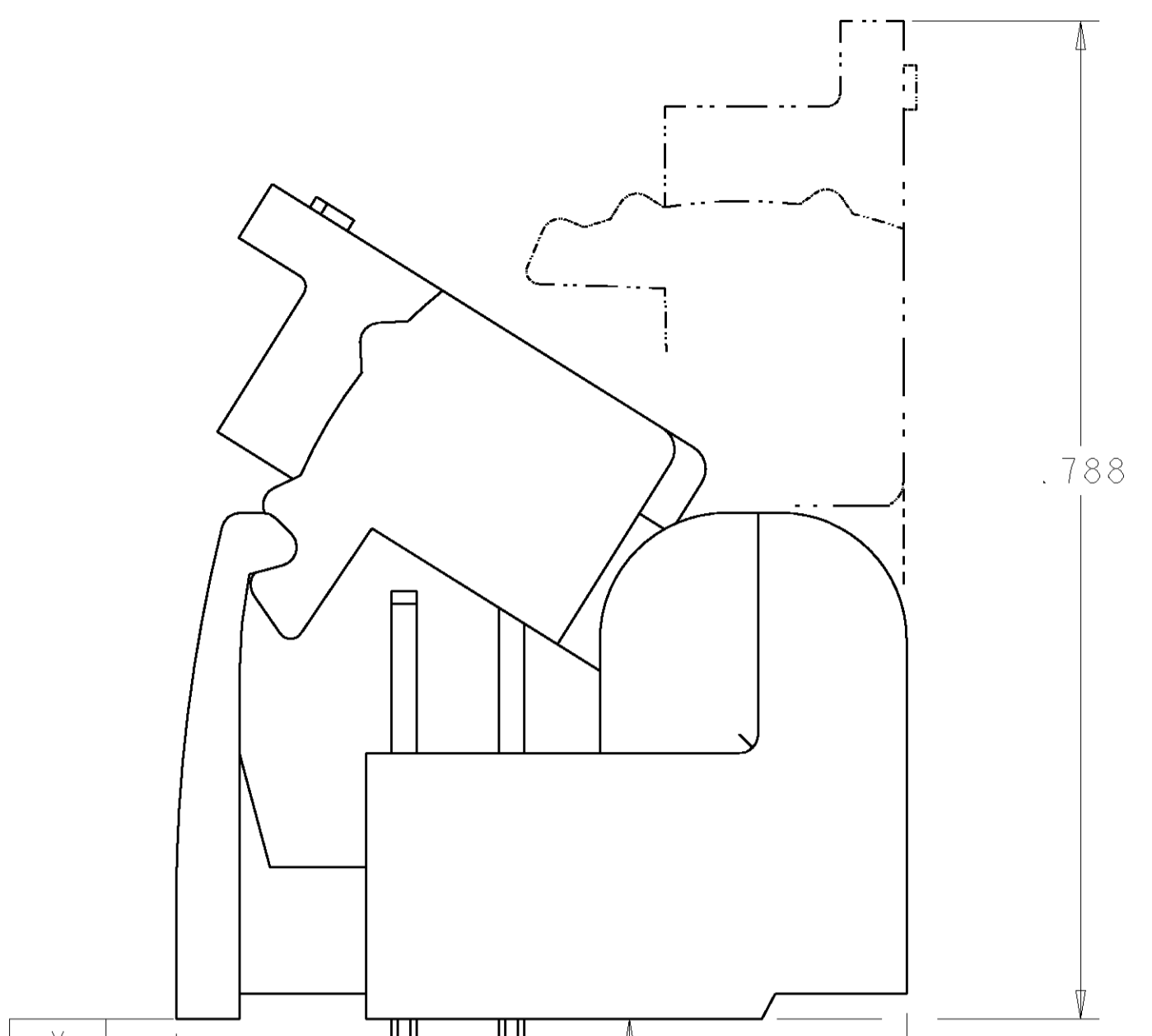
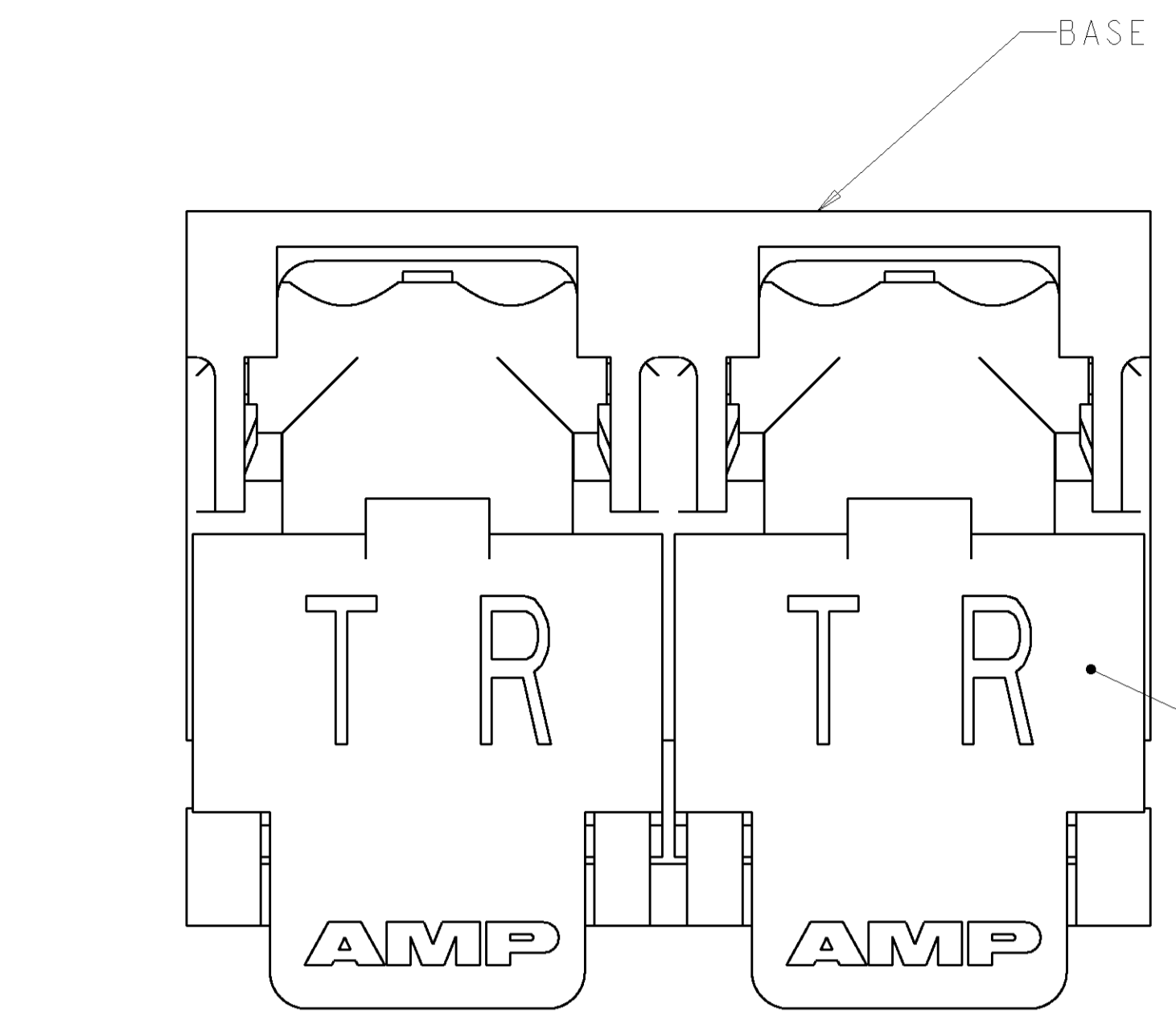
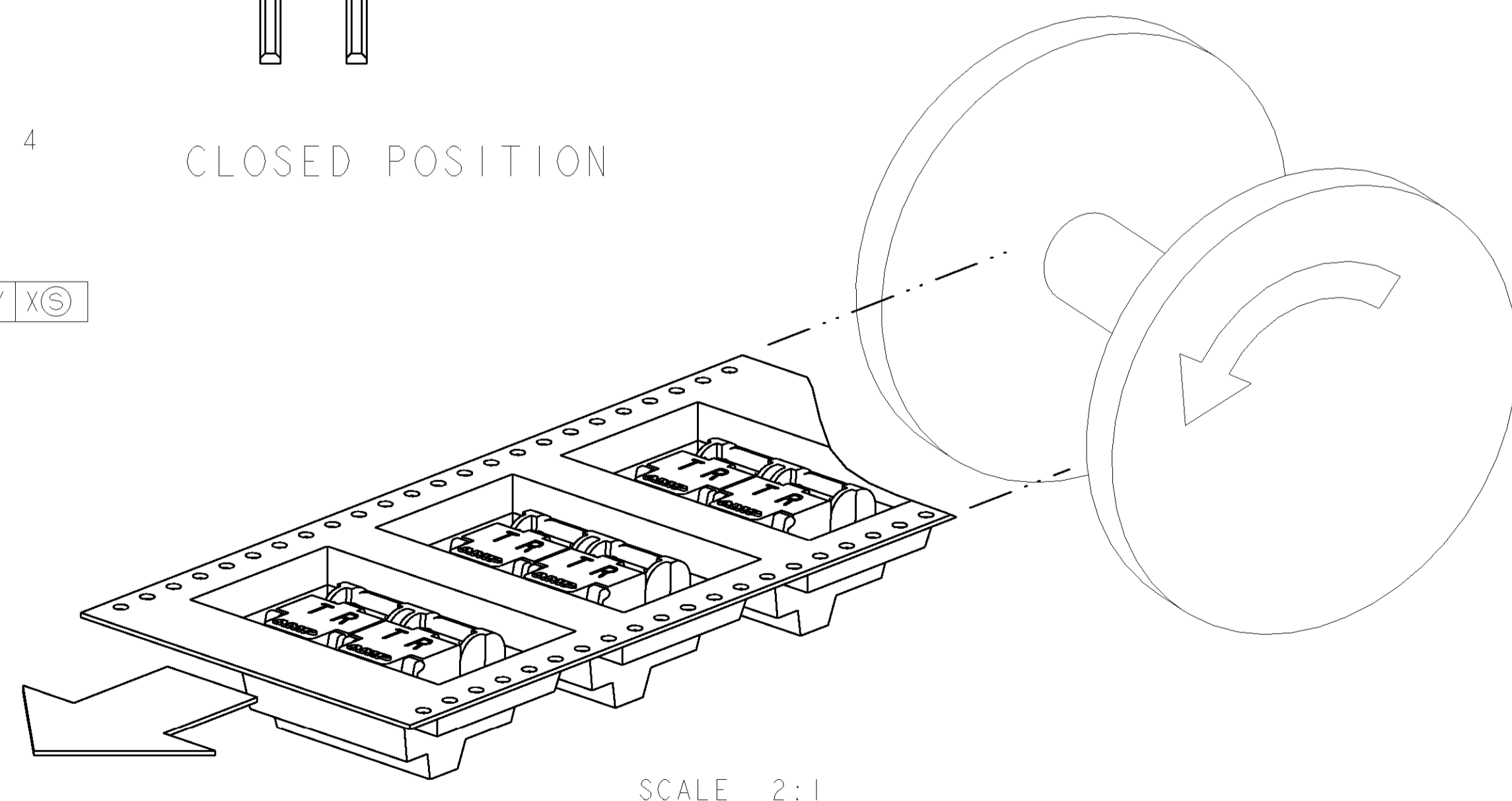
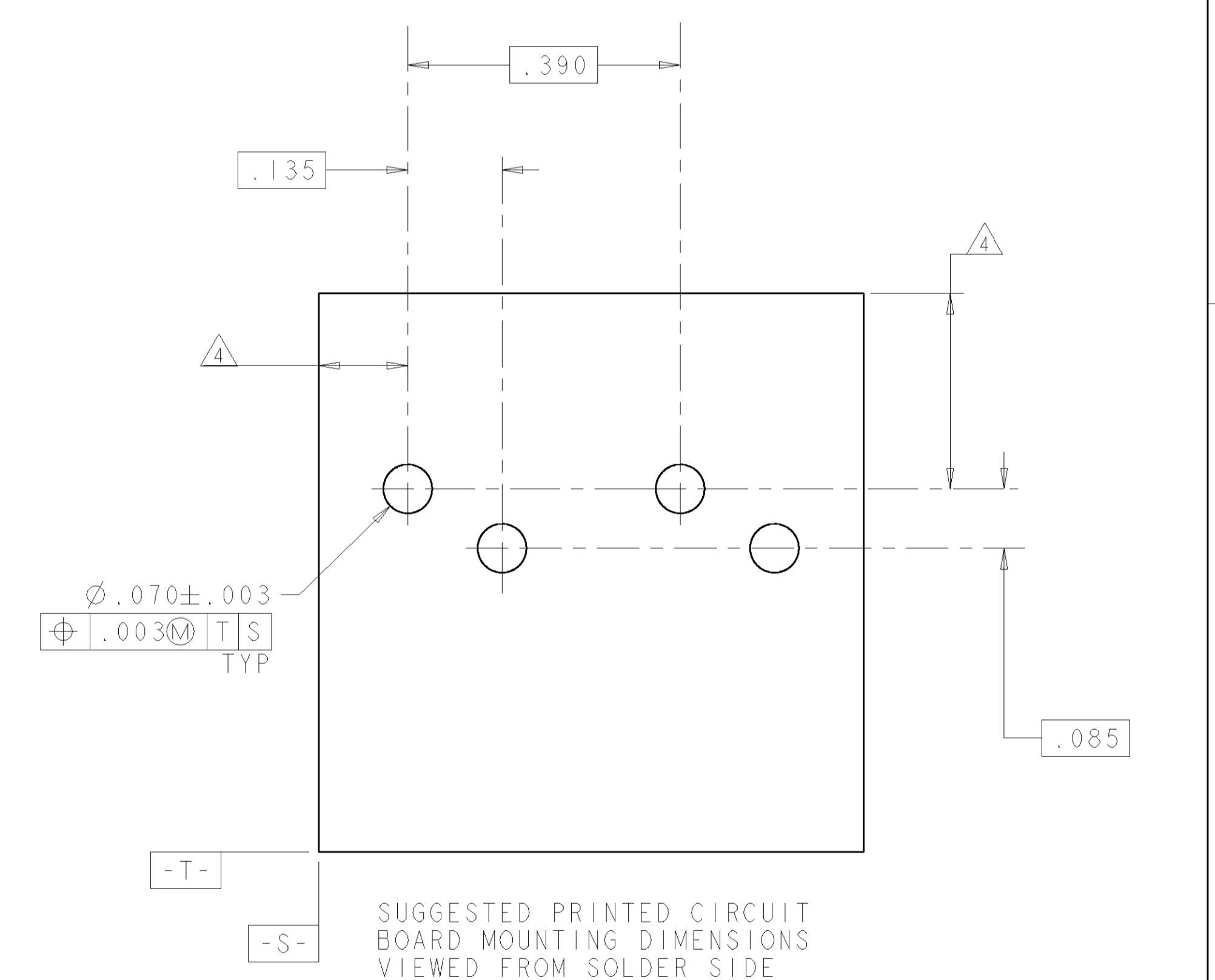

TAPE & REEL	GREEN	GREEN	TAN	1-1339223-1
TRAY	RED	GREEN	TAN	1339223-1
PACKAGING	R	T	WIRE STUFFER	PART NUMBER
COLOR CODE				

<small>THIS DRAWING IS UNPUBLISHED. RELEASED FOR PUBLICATION. ALL RIGHTS RESERVED. ALL DIMENSIONS ARE IN INCHES UNLESS OTHERWISE SPECIFIED. DIMENSIONS IN PARENTHESES ARE FOR INFORMATION ONLY. DIMENSIONS IN PARENTHESES ARE FOR INFORMATION ONLY. DIMENSIONS IN PARENTHESES ARE FOR INFORMATION ONLY.</small>		DWN: R. ZARBOCK 05OCT99 ENR: M. DERSTINE 05OCT99 APVD: M. DERSTINE 05OCT99	AMP AMP Incorporated Harrisburg, PA 17105-3608
DIMENSIONS: INCHES TOLERANCES UNLESS OTHERWISE SPECIFIED: 0 PLC ± 1 PLC ±.01 2 PLC ±.01 3 PLC ±.005 4 PLC ± ANGLES ± FINISH -	PRODUCT SPEC APPLICATION SPEC WEIGHT CUSTOMER DRAWING	NAME: ASSEMBLY, DOUBLE PAIR, SINGLE ENTRY, PIVOT II CONNECTOR SIZE: A1 CAGE CODE: 00779 DRAWING NO: 1339223 SCALE: 6:1 SHEET 1 OF 1 REV G	