

6.24 ~ 8.50 GHz UWB - Chip Antenna



ACR0301U

Request Samples



Check Inventory



3.2 x 1.6 x 1.1 mm
RoHS/RoHS II Compliant
MSL Level = 1

Features

- Compact size
- UWB Bands in 6.24 GHz ~ 8.5 GHz
- Manufactured using LTCC technology
- High Gain of 4.5 dBi
- Omni-directional Pattern
- High Efficiency of 70 ~ 80 %
- Surface mount component

Applications

- UWB Applications
- IoT
- M2M
- Real time tracking
- Location based services
- Personal Area Networks (PAN)
- Short range, high speed data links for Medical and Commercial equipment

Product Dimensions

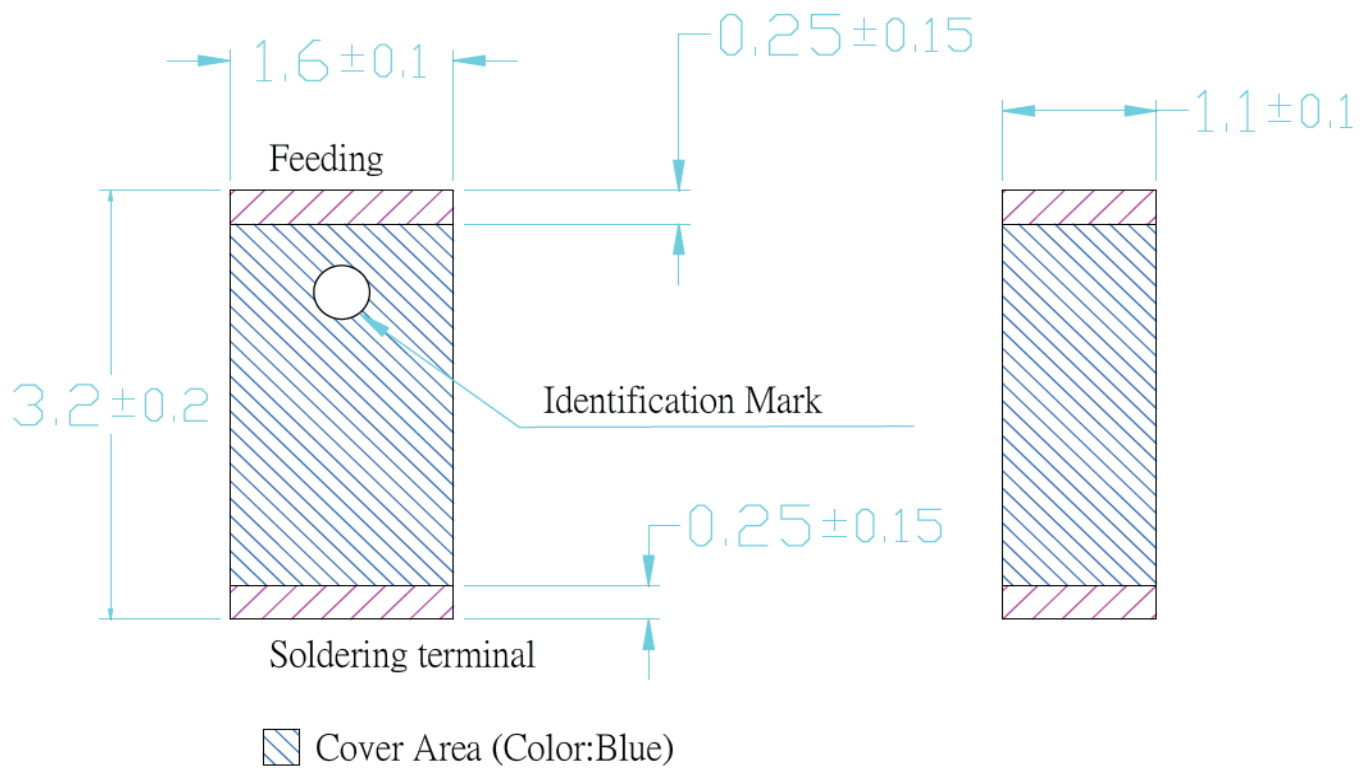

Unit : mm

6.24 ~ 8.50 GHz UWB - Chip Antenna



ACR0301U

Request Samples



Check Inventory



3.2 x 1.6 x 1.1 mm
RoHS/RoHS II Compliant
MSL Level = 1

Electrical Specification

Parameter	Specification			Unit
	Min	Typ	Max	
Operating Frequency	6.24		8.5	GHz
Center Frequency		7.37		
VSWR			2.0	
Polarization	Linear			
Peak Gain			4.5	dBi
Efficiency		70 ~ 80		%
Impedance		50		Ω
Azimuthal Beamwidth	Omni-directional			
Input Power	Continuous		3	W
	Up to 5 minutes		5	

Note: All test measurements were conducted with the antenna on a 42.6x22.6 mm Evaluation board. Please note that the performance is dependent on the ground plane dimensions, matching network and application environment.

Mechanical Specification

Parameter	Specification
Antenna Dimension	3.2 x 1.6 x 1.1 mm
Antenna Ground Clearance Area	8 x 7.8 mm
Evaluation board Dimension	42.6 x 22.6 x 0.8 mm
Manufacturing Technology	Multilayer LTCC Chip
Mounting Type	Surface Mount

Environmental Specification

Parameter	Specification
Operating Temperature	-40°C to +85°C
Storage Temperature	+5°C to +40°C
Relative Humidity	30 ~ 70 %
Pb-free	Yes



5101 Hidden Creek Ln Spicewood TX 78669
Phone: 512-371-6159 | Fax: 512-351-8858
For terms and conditions of sales, please visit:
www.abracon.com

REVISED: 07-19-21

ABRACON IS
ISO9001-2015
CERTIFIED

6.24 ~ 8.50 GHz UWB - Chip Antenna



ACR0301U

Request Samples



Check Inventory



3.2 x 1.6 x 1.1 mm
RoHS/RoHS II Compliant
MSL Level = 1

Evaluation Board Dimensions

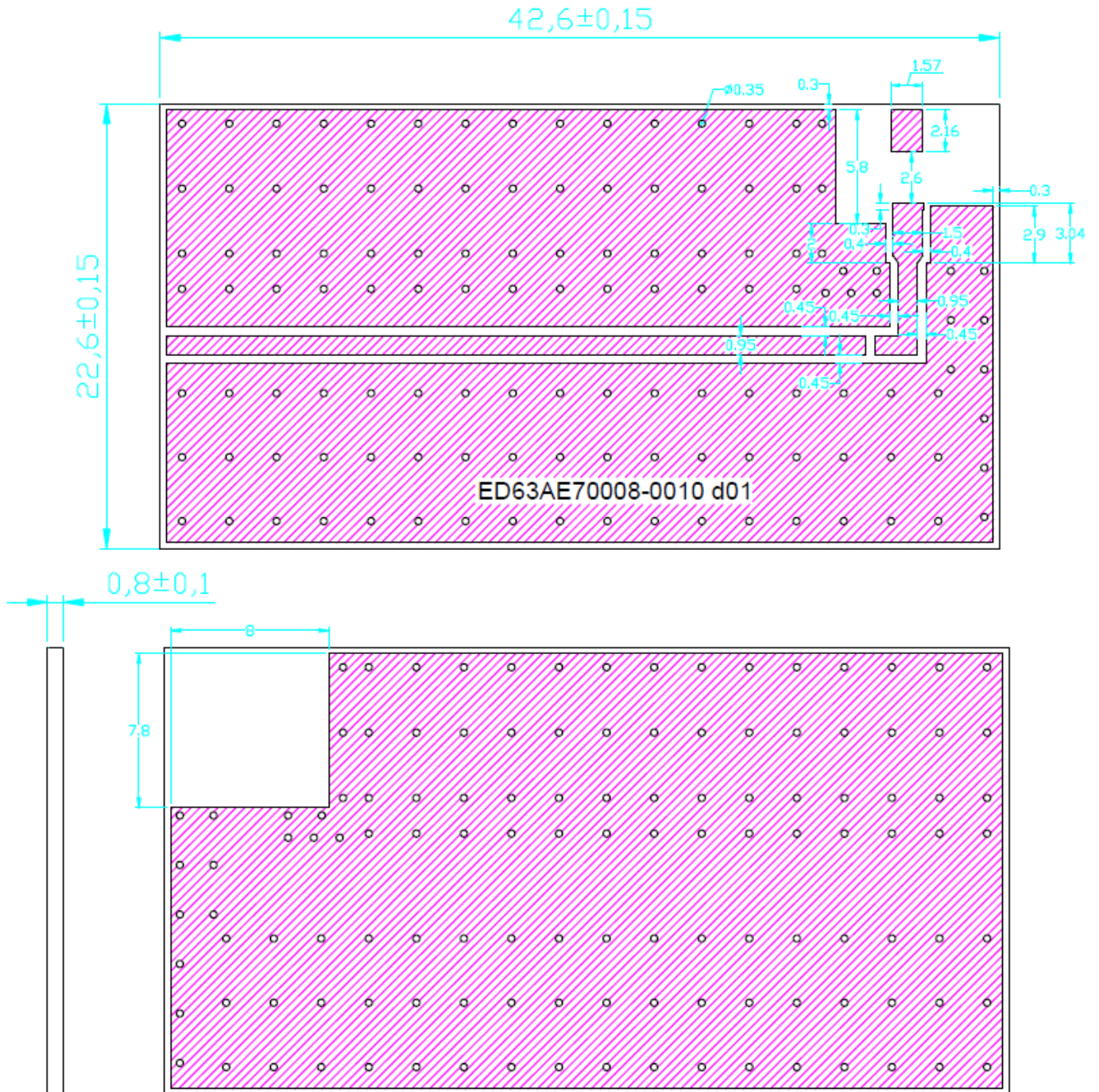

Unit: mm



5101 Hidden Creek Ln Spicewood TX 78669
Phone: 512-371-6159 | Fax: 512-351-8858
For terms and conditions of sales, please visit:
www.abracon.com

REVISED: 07-19-21

ABRACON IS
ISO9001-2015
CERTIFIED

6.24 ~ 8.50 GHz UWB - Chip Antenna



ACR0301U

Request Samples



Check Inventory



3.2 x 1.6 x 1.1 mm
RoHS/RoHS II Compliant
MSL Level = 1

Recommended Layout Dimensions

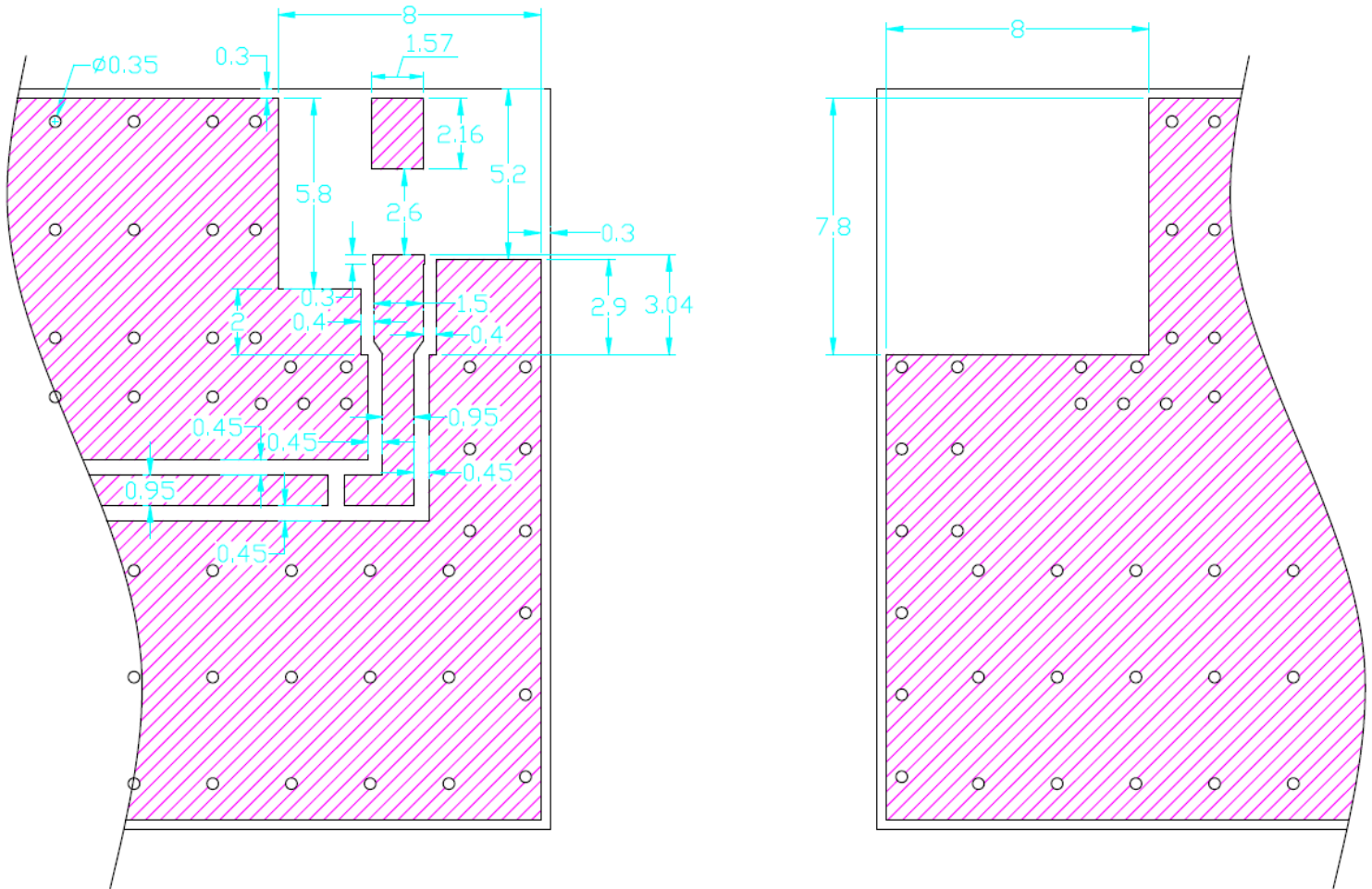

Unit : mm



5101 Hidden Creek Ln Spicewood TX 78669
Phone: 512-371-6159 | Fax: 512-351-8858
For terms and conditions of sales, please visit:
www.abracon.com

REVISED: 07-19-21

ABRACON IS
ISO9001-2015
CERTIFIED

6.24 ~ 8.50 GHz UWB - Chip Antenna



ACR0301U

Request Samples



Check Inventory



3.2 x 1.6 x 1.1 mm
RoHS/RoHS II Compliant
MSL Level = 1

Reflection Characteristics - Return Loss

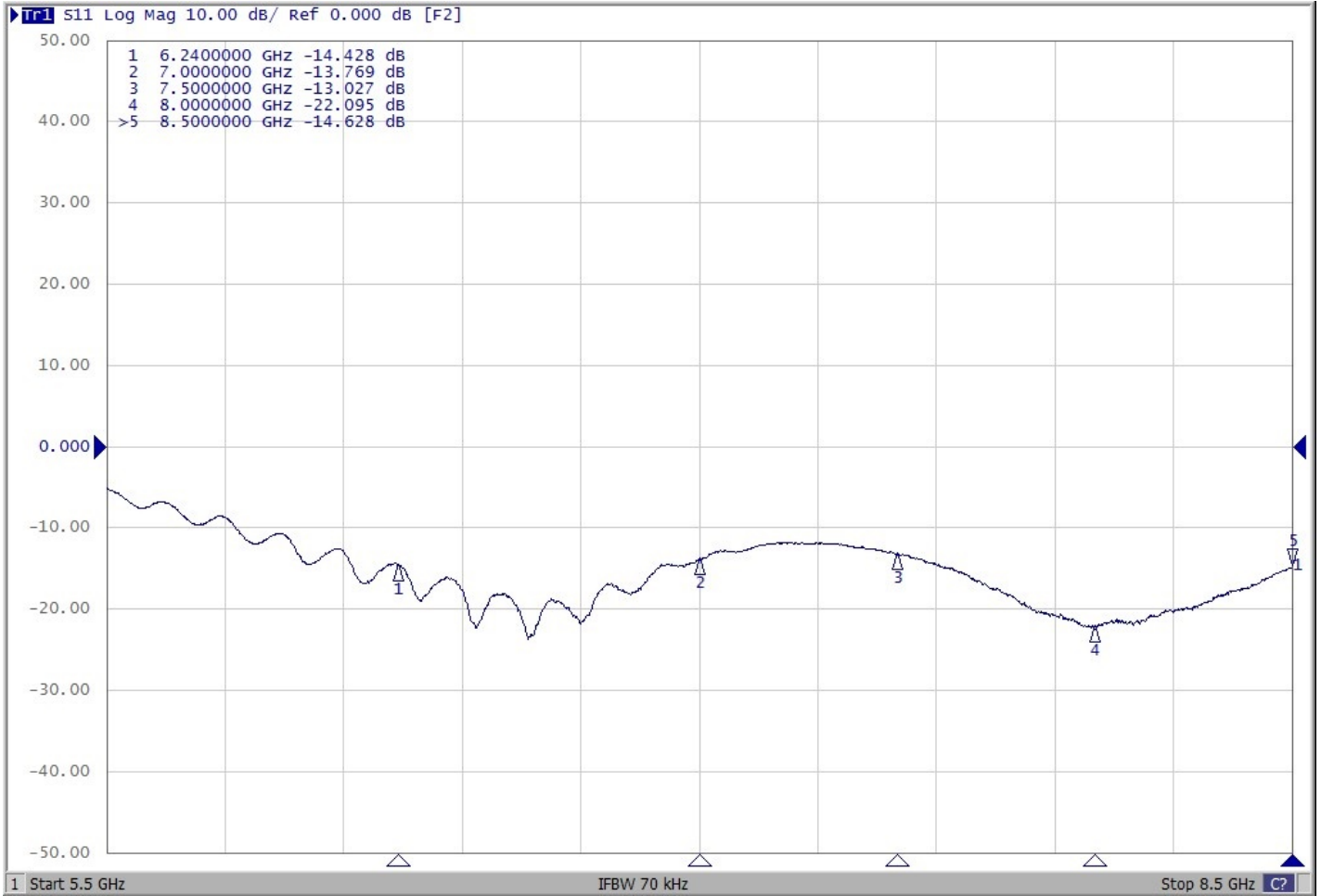

6.24 ~ 8.50 GHz UWB - Chip Antenna



ACR0301U

Request Samples



Check Inventory



3.2 x 1.6 x 1.1 mm
RoHS/RoHS II Compliant
MSL Level = 1

Radiation Characteristics – 2D Pattern

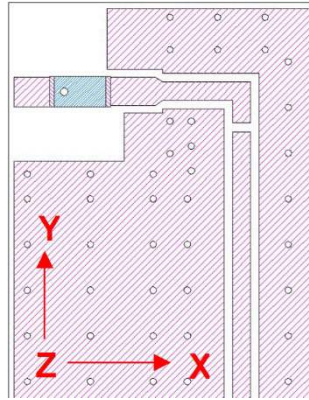

6240 MHz

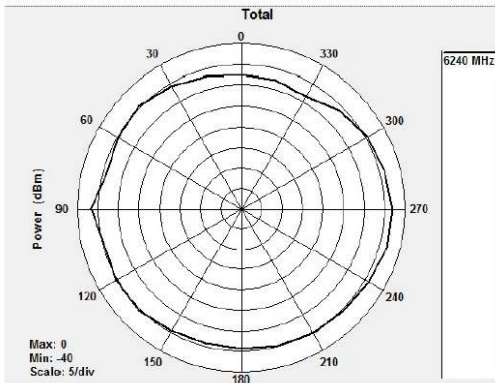

XY-Plane

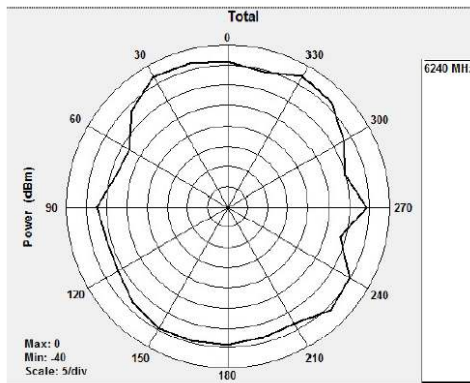

XZ-Plane

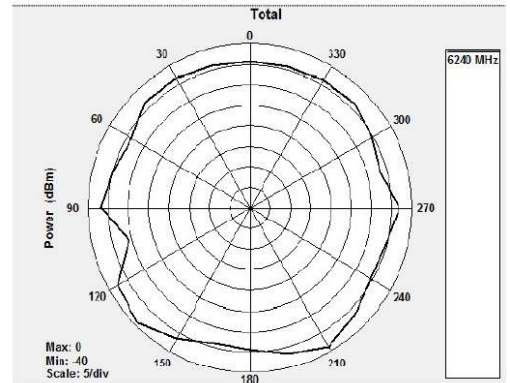

YZ-Plane

7000/7500/8000 MHz

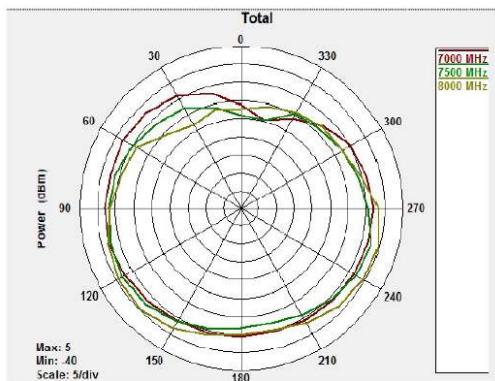

XY-Plane

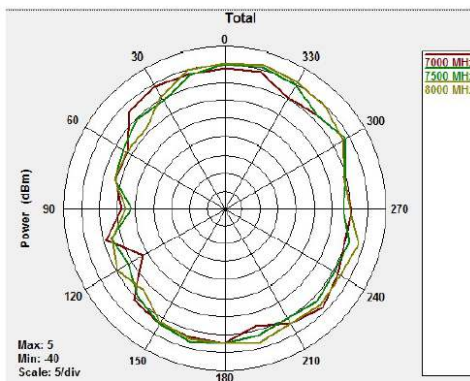

XZ-Plane

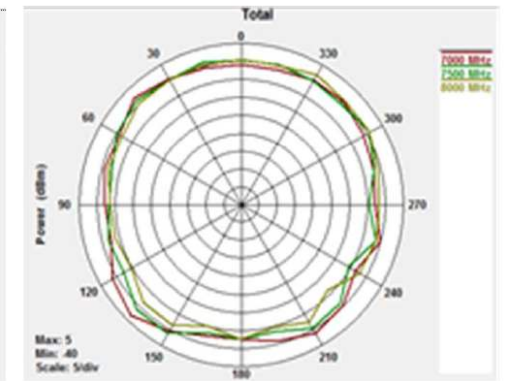

YZ-Plane



5101 Hidden Creek Ln Spicewood TX 78669
Phone: 512-371-6159 | Fax: 512-351-8858
For terms and conditions of sales, please visit:
www.abracon.com

REVISED: 07-19-21

ABRACON IS
ISO9001-2015
CERTIFIED



ACR0301U

Request Samples



Check Inventory



3.2 x 1.6 x 1.1 mm
RoHS/RoHS II Compliant
MSL Level = 1

Radiation Characteristics – 3D Pattern

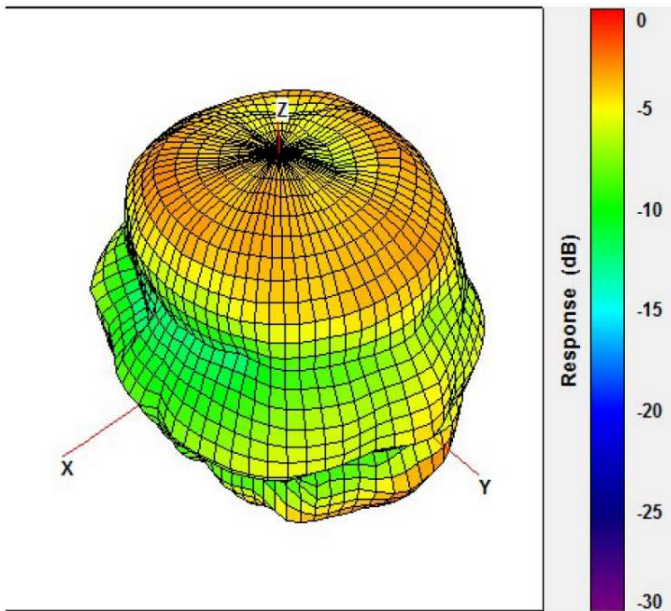

6240 MHz

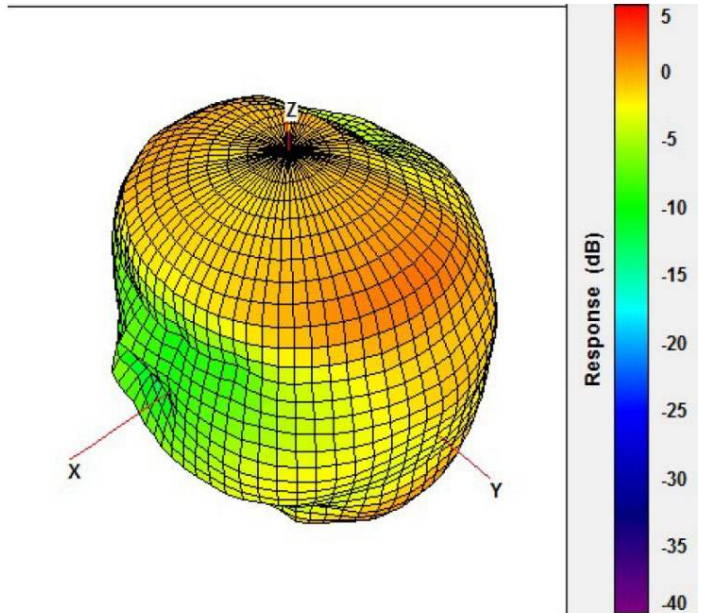

7000 MHz

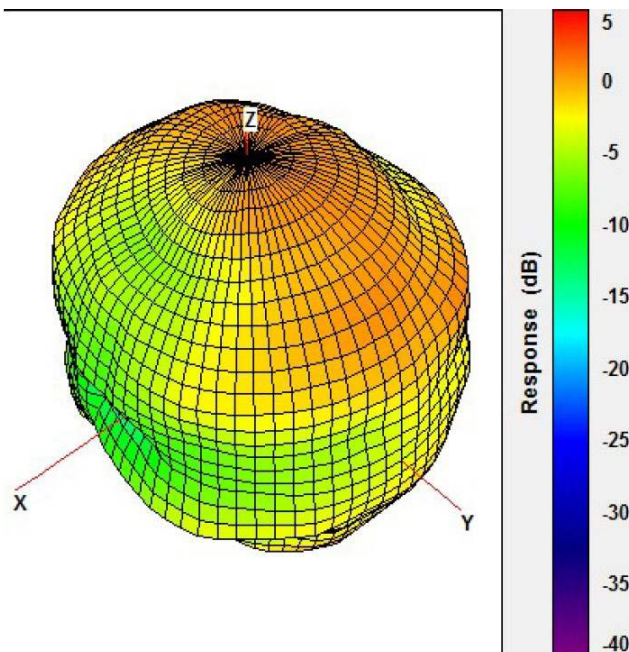

7500 MHz

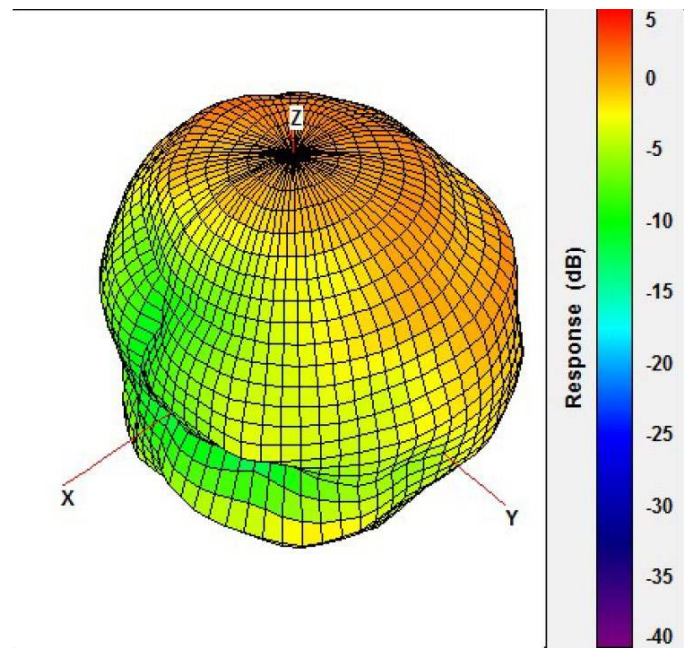

8000 MHz

6.24 ~ 8.50 GHz UWB - Chip Antenna



ACR0301U

Request Samples



Check Inventory



3.2 x 1.6 x 1.1 mm
RoHS/RoHS II Compliant
MSL Level = 1

Reliability Test

Items	Test Method	Standard
Resistance to soldering heat JIS C 0050-5.4	<ol style="list-style-type: none"> Preheating temperature: 120 ~ 150 °C Duration: 1 min Solder Temperature: 270 ± 5 °C Immersion Time: 10 ± 1 s Solder: Sn3Ag0.5Cu for lead free Measurement to be made after keeping at room temperature for 24 ± 2 hrs 	<ol style="list-style-type: none"> Specimens shall be free of any traffic discontinuities during the test. (No mechanical damage) The appearance of the product, and electrical properties to meet the requirements under operational temperature range within -40 ~ +85 °C Loss of metallization on the edges of each electrode shall not exceed 25%
Solderability JIS C 0050-4.6 JESD22-B102D	<ol style="list-style-type: none"> Solder bath temperature : 235 +/- 5 C Immersion time : 2 ± 0.5 sec Solder : Sn3Ag0.5Cu for lead-free 	At least 95% of a surface of each terminal electrode must be covered by fresh solder.
Adhesive Strength of Termination JIS C 0051- 7.4.3	<ol style="list-style-type: none"> Pressurizing force : 5N (LGA terminal series) ; 5N(≤0603) ; 10N(>0603) Test time : 10±1 s 	No remarkable damage or removal of the termination.
Vibration JIS C 0040	<ol style="list-style-type: none"> Vibration Frequency: 10~50~10 Hz (1min) Amplitude:1.5 mm Sweep Direction: 6 Hrs = X(2H), Y(2H), Z(2H) Examine the appearance and functions after the test. 	<ol style="list-style-type: none"> Specimens shall be free of any traffic discontinuities during the test. (No mechanical damage) The appearance of the product, and electrical properties to meet the requirements under operational temperature range within -40 ~ +85 °C
Drop Test JIS C 0044	<ol style="list-style-type: none"> Drop the object onto a concrete surface or steel surface from a height of 75 cm. Number of Times : 6 surfaces for each unit – 2 times each side. Examine the appearance and functions after the test. 	
Bending test JIS C 0051- 7.4.1	<ol style="list-style-type: none"> The middle part of substrate shall be pressurized by means of the pressurizing rod at a rate of about 1 mm/s per second until the deflection becomes 1mm/s and then pressure shall be maintained for 5±1 sec. Measurement to be made after keeping at room temperature for 24±2 hours 	



5101 Hidden Creek Ln Spicewood TX 78669
 Phone: 512-371-6159 | Fax: 512-351-8858
 For terms and conditions of sales, please visit:
www.abracon.com

REVISED: 07-19-21

ABRACON IS
 ISO9001-2015
 CERTIFIED

6.24 ~ 8.50 GHz UWB - Chip Antenna



ACR0301U

Request Samples



Check Inventory



3.2 x 1.6 x 1.1 mm
RoHS/RoHS II Compliant
MSL Level = 1

<p>Temperature cycle JIS C 0025</p>	<ol style="list-style-type: none"> 1. 30±3 minutes at -40°C±3°C 2. 10~15 minutes at room temperature 3. 30±3 minutes at +85°C±3°C 4. 10~15 minutes at room temperature 5. Number of cycles: 100 continuous cycles 6. Measurement to be made after keeping at room temperature for 24±2 hrs 	<ol style="list-style-type: none"> 1. Specimens shall be free of any traffic discontinuities during the test. (No mechanical damage) 2. The appearance of the product, and electrical properties to meet the requirements under operational temperature range within -40 ~ +85 °C
<p>High Temperature JIS C 0021</p>	<ol style="list-style-type: none"> 1. Temperature: 85°C±2°C 2. Time: 1000+24/-0 H 3. Examine the appearance and functions after taken out at room temperature for 24±2H. 	
<p>Low Temperature JIS C 0020</p>	<ol style="list-style-type: none"> 1. Temperature: -40°C±2°C 2. Time: 1000+24/-0 H 3. Examine the appearance and functions after taken out at room temperature for 24±2H. 	
<p>Humidity (Steady conditions) JIS C 0022</p>	<ol style="list-style-type: none"> 1. Temperature range: 40°C±2°C 2. Humidity Range: 90%~95% R.H. 3. Cycle times: 1000+24/-0 H 4. Examine the appearance and functions after taken out at room temperature for 24H±2H. 500 hrs measuring the first data then 1000 hrs data. 	



5101 Hidden Creek Ln Spicewood TX 78669
 Phone: 512-371-6159 | Fax: 512-351-8858
 For terms and conditions of sales, please visit:
www.abracon.com

REVISED: 07-19-21

ABRACON IS
 ISO9001-2015
 CERTIFIED



ACR0301U

Request Samples



Check Inventory



3.2 x 1.6 x 1.1 mm
RoHS/RoHS II Compliant
 MSL Level = 1

Infrared Soldering Profile

A typical example of soldering processes that provides reliable joints without any damage is given below. This product can sustain a reflow process three times, and at temperatures below 260 °C.

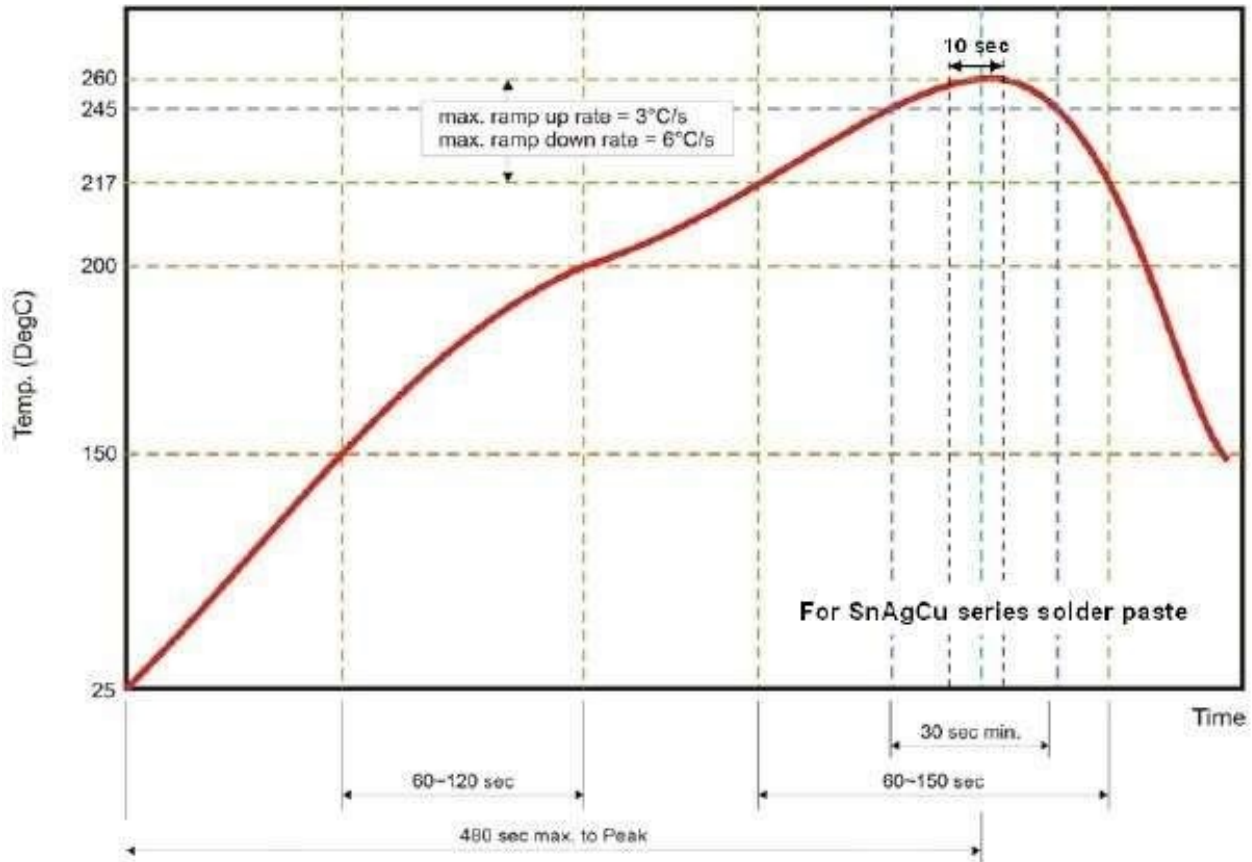

Caution

- Do not place the product in a corrosive or corrosive gas environment as it may cause oxidation of the metal electrode, resulting in poor solderability.
- Products should be stored on the palette for the prevention of the influence from external factors including humidity, dust.
- Products should be stored in an environment without being exposed to but not limited to heat shock, vibration, direct sunlight.
- Products should be stored in an airtight packaged condition.



ACR0301U

Request Samples



Check Inventory



3.2 x 1.6 x 1.1 mm
RoHS/RoHS II Compliant
 MSL Level = 1

Packaging

Packaging Type: Tape & Reel
 Number of Pieces per Reel: 2000

Reel Specifications

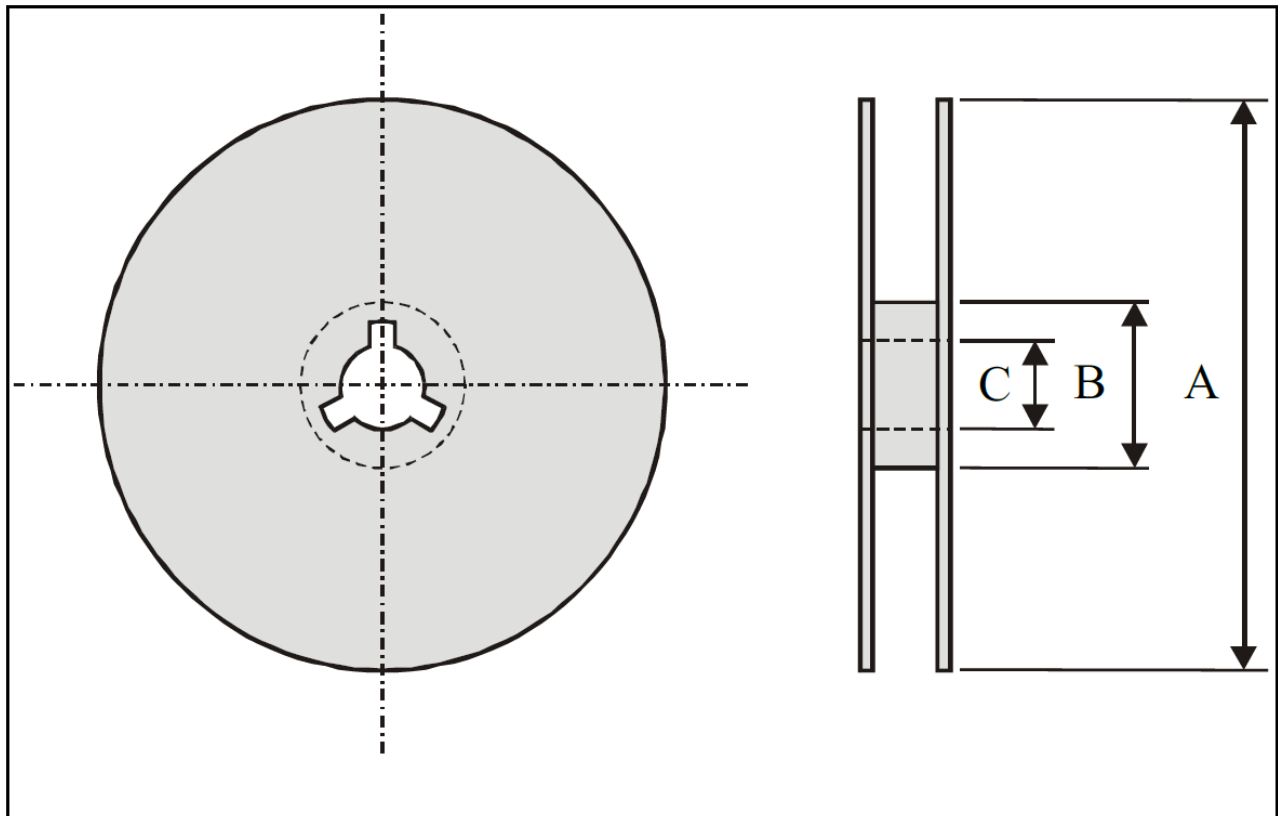

Dimension	Specification (mm)
A	D178
B	D60
C	D13.5

6.24 ~ 8.50 GHz UWB - Chip Antenna



ACR0301U

Request Samples



Check Inventory



3.2 x 1.6 x 1.1 mm
RoHS/RoHS II Compliant
 MSL Level = 1

Packaging

Reel Tape Specifications

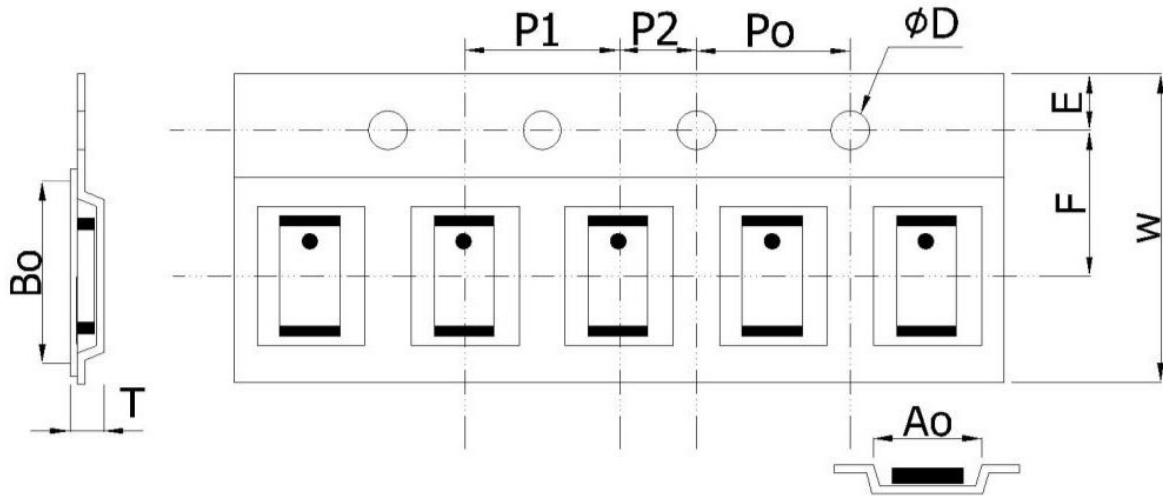

Dimension	Specification (mm)
Ao	1.81 ± 0.10
Bo	3.42 ± 0.10
φD	1.55 ± 0.05
T	1.26 ± 0.10
W	8.20 +0.10/-0.30
E	1.75 ± 0.10
F	3.50 ± 0.05
Po	4.00 ± 0.10
P1	4.00 ± 0.10
P2	2.00 ± 0.10

ATTENTION: Abracon LLC's products are COTS – Commercial-Off-The-Shelf products; suitable for Commercial, Industrial and, where designated, Automotive Applications. Abracon's products are not specifically designed for Military, Aviation, Aerospace, Life-dependent Medical applications or any application requiring high reliability where component failure could result in loss of life and/or property. For applications requiring high reliability and/or presenting an extreme operating environment, written consent and authorization from Abracon LLC is required. Please contact Abracon LLC for more information.



5101 Hidden Creek Ln Spicewood TX 78669
 Phone: 512-371-6159 | Fax: 512-351-8858
 For terms and conditions of sales, please visit:
www.abracon.com

REVISED: 07-19-21

ABRACON IS
 ISO9001-2015
 CERTIFIED