

REV.	DATE	ECR NO.	DESCRIPTION
A	06/05/03	XXXXXX	UPDATE DRAWING FORMAT
B	11/23/11	2259	ADD THE TOLERANCE OF Ø4.1

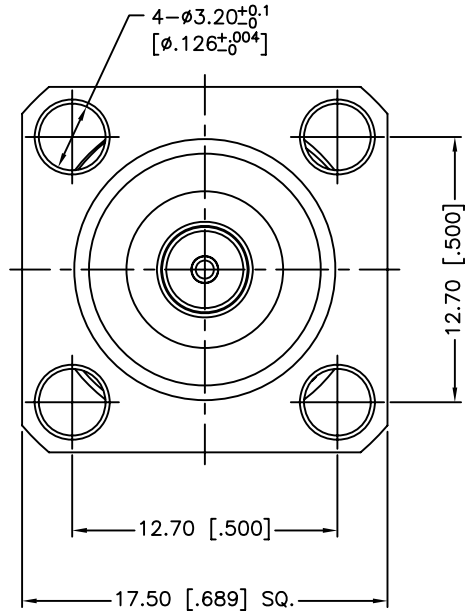
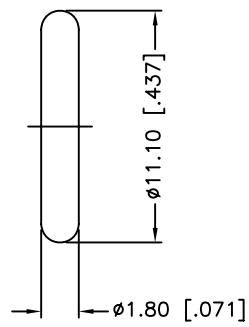
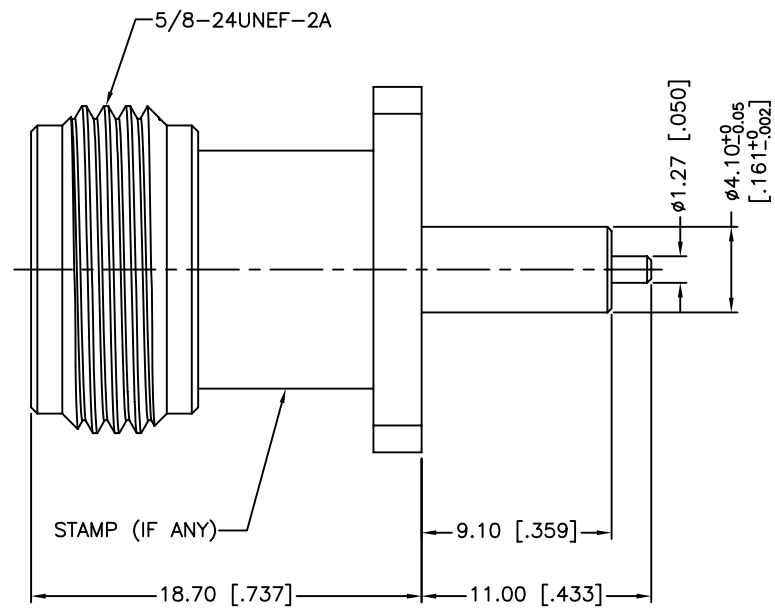
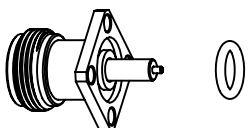

1. IMPEDANCE: 50 OHM
2. FREQUENCY RANGE: DC - 11 GHz
3. DIELECTRIC WITHSTANDING VOLTAGE: 2500 VRMS

UNLESS OTHERWISE SPECIFIED DIMENSIONS ARE IN MILLIMETERS. DIMENSIONS IN [ ] ARE IN INCHES AND FOR CUSTOMER REFERENCE ONLY.				APPROVALS	DATE	<b>Amphenol Connex</b>		
5	GASKET	SILICONE	RED	1	DRAWN C.WANG		11/23/11	
4	LOCK RING	BRASS	NEXCOTE	1	CHECKED			
3	CONTACT PIN	PHOSPHOR BRONZE	GOLD	1	ISSUED			
2	INSULATOR	PTFE	NATURAL	1	SHEET 1 OF 1			
1	BODY	BRASS	NEXCOTE	1				
	DESCRIPTION	MATERIAL	FINISH	QTY	DO NOT SCALE DRAWING		PART DESCRIPTION <b>N PANEL RECEPTACLE JACK EXTENDED TEFLON (.359"/.433")</b>	
					CAD FILE C:/CONNEX/172117.DWG	PART NO. <b>172117</b>		
					DWG. NO. 172117.DWG	REV. NC	SIZE A	SCALE NA

UNLESS OTHERWISE SPECIFIED TOLERANCES FOR MILLIMETERS ARE:  
0.5 - 8mm ± 0.20mm  
8 - 30mm ± 0.40mm  
30 - 120mm ± 0.50mm

UNLESS OTHERWISE SPECIFIED TOLERANCES FOR INCHES ARE:  
.020 - .315 = ± 0.007"  
.315 - 1.180 = ± 0.015"  
1.180 - 4.724 = ± 0.020"