

PART NUMBER	REV	TERMINATOR	FEED TYPE	DESCRIPTION
1529190-1	A	BENCH & LEADMAKER	MECH POST FEED	HDI APPLICATOR
7-1529190-1	A	BENCH & LEADMAKER	MECH POST FEED	-1 AND SPARE PARTS
7-1529190-7	A	-	-	SPARE PARTS KIT

LOC	DIST	REV	DATE	BY	APPD
A	66		01AUG2006	DP	MC

CRIMP DATA STOCKO TERMINAL STOCKO CRIMP SPECS

CRIMP	SIZE	TYPE	RANGE
WIRE	3.56 [.140 IN]	F	1.27mm ² - 2.50mm ²
INSUL	4.32 [.170 IN]	F	2.65-3.60 [.104-.142 IN]

WIRE STRIP LENGTH	APPL INSTRUCTIONS
5.20-6.00 [.205-.236 IN]	408-8323 & 408-8490

TERMINAL STOCKO F225	FEED
APPL SPEC	24.15 [.951 IN]

TYCO PN	MANUF'S PN		
1949083-1	RSB 7208 A 4-2,5	-	-

WIRE SIZE	CRIMP HEIGHT	REF SETTING
2.50mm ²	2.55 ± 0.02 [.100 ± .0008 IN]	C0
1.50mm ²	2.25 ± 0.02 [.089 ± .0008 IN]	E0
1.27mm ² or 16 AWG	2.22 ± 0.02 [.087 ± .0008 IN]	E4

- 1 RECOMMENDED SPARE PARTS
- 2. GREASE RAM, CAM, CAM FOLLOWER AND FEED ROD LIGHTLY.
- 3 CERTAIN TERMINALS REQUIRE LUBRICATION. REFER TO THE APPLICATOR INSTRUCTION SHEET FOR MORE INFORMATION.
- 4 ALL CRIMP DATA SUPPLIED BY STOCKO PN RSB 7209/7208 A X - 2,5 REFERS.
- 5 WIRE RANGE STATED IS THAT OF THE APPLICATOR. TERMINAL WIRE RANGE IS >1.00 - 3.00mm² OR 16 - 14 AWG.
- 6 ITEM 56, CUT TO LENGTH AT ASSEMBLY.

* WARNING
 ON INSTALLATION, SET WIRE DISC TO LARGEST WIRE SIZE SETTING. USE OF SETTINGS BELOW MIN. REQUIRED CRIMP HEIGHT SETTING WILL CAUSE DAMAGE TO CRIMP TOOLING.

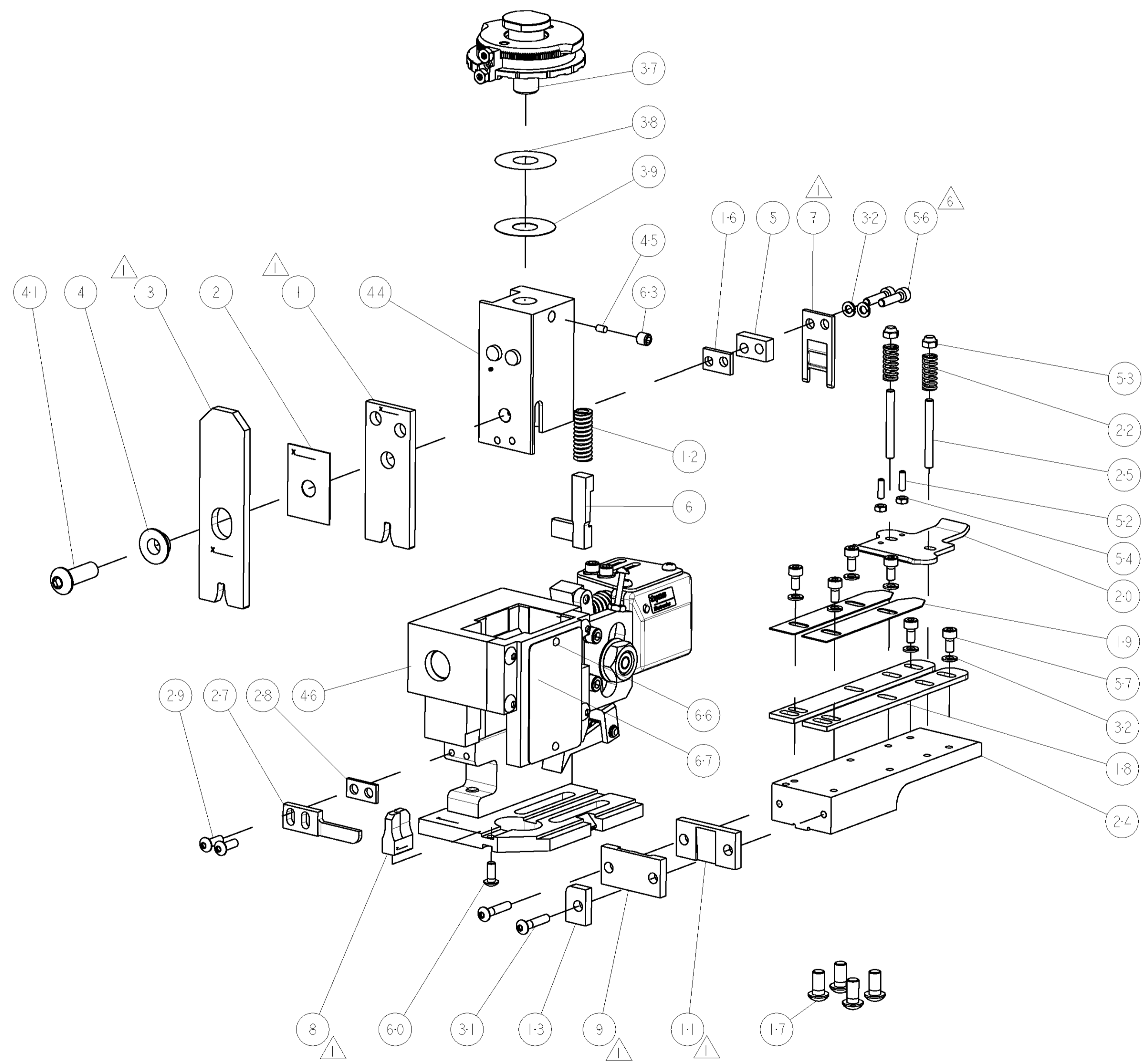
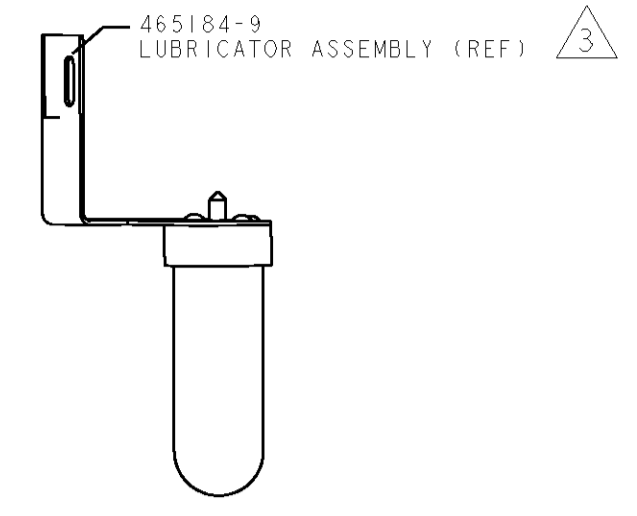
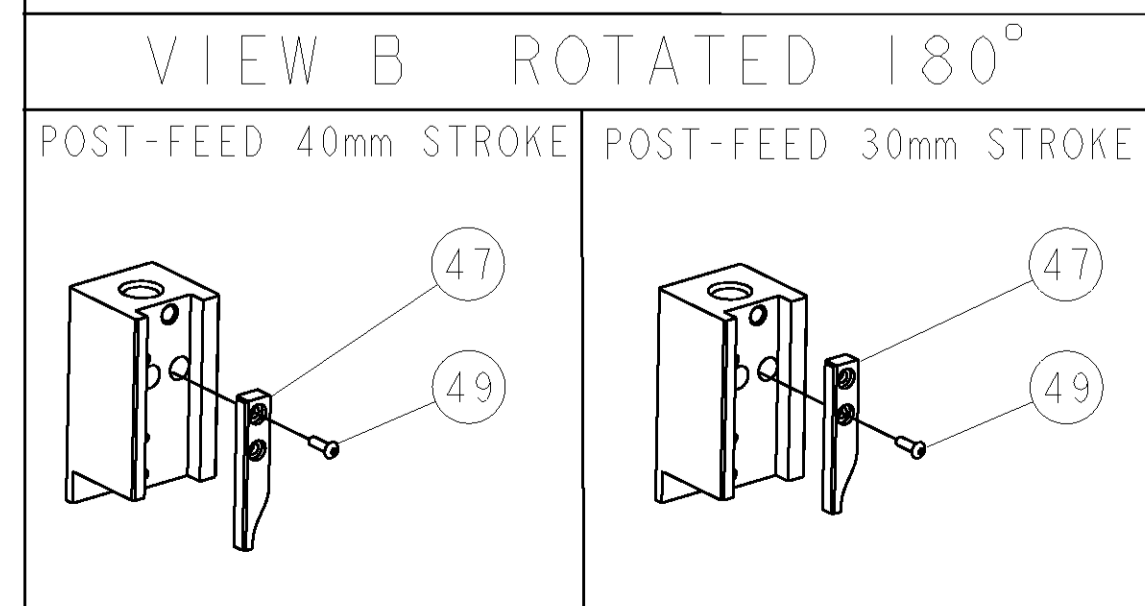

QTY	DESCRIPTION	ITEM NO
-	1338705-4 DOCUMENTATION PACKAGE	71
-	461264-5 PLATE, IDENTIFICATION	67
-	21017-2 SCREW, DRIVE	66
-	3-18031-0 SCR, SET, CUP POINT M6 X 6.0	63
-	18024-7 SCR, BTN SKT HD CAP (M4 X 10.0)	60
-	1-18023-0 SCR, SKT HD CAP M4 X 8.0	57
-	1-18023-3 SCR, SKT HD CAP M4 X 16.0	56
-	18029-1 NUT, HEX, REG M3	54
-	986965-1 NUT, LOCK, HEX, TORQUE (M4)	53
-	2-18032-2 SCR, SET, FLT POINT M3 X 10.0	52
-	18024-3 SCR, BTN SKT HD CAP (M3 X 10.0)	49
-	1338676-1 CAM, UNIVERSAL POST-FEED	47
-	1338662-1 SUB ASSY, APPLICATOR FRAME	46
-	690191-1 PLUG, NYLON	45
-	1333260-1 RAM	44
-	2-18024-6 SCR, BTN SKT HD CAP (M8 X 25.0)	41
-	690125-1 SHIM SUB-ASSY	39
-	469367-4 SHIM	38
-	879103-2 FINE ADJUST HEAD SUBASSY	37
-	18025-2 WASHER, SPRG LOCK, REG M4	32
-	1-18024-0 SCR, BTN SKT HD CAP (M4 X 20.0)	31
-	18024-8 SCR, BTN SKT HD CAP (M4 X 12.0)	29
-	3-690451-2 SPACER, STRIPPER	28
-	240639-1 STRIPPER (MACHINING)	27
-	1320906-1 STUD, THREADED	25
-	1320995-1 PLATE, STRIP GUIDE	24
-	4-22281-1 SPRING, DRAG	22
-	1338665-1 DRAG	20
-	1338664-1 GUIDE, UPPER STRIP	19
-	1338663-5 GUIDE, LOWER STRIP	18
-	1-18024-8 SCR, BTN SKT HD CAP (M6 X 12.0)	17
-	1338708-1 SPACER, SLUG BLADE	16
-	690481-2 SPACER, HOLD DOWN	13
-	23846-1 SPRING, DIE	12
-	240644-1 PLATE, REAR SHEAR	11
-	690482-3 PLATE, FRONT SHEAR	9
-	1633383-2 ANVIL, COMBINATION	8
-	690474-3 BLADE, SLUG	7
-	3-455892-4 HOLD DOWN, TERMINAL	6
-	6-240641-5 SPACER	5
-	238009-2 BLOCK, FL CRIMPER SPACER	4
-	9-683453-3 CRIMPER, INSULATION PREMIUM	3
-	455888-4 SPACER, CRIMPER	2
-	1-456425-2 CRIMPER, WIRE	1

QTY	PART NO	DESCRIPTION	ITEM NO
-77	-71	-1	