

ITEM #	PART #	QTY	DESCRIPTION
1	MAJ-60-12	1	OM PLUG HOUSING
2	MAJ-60-08P	1	JACK INSERT, 10 COND
3	MAP-60-06	1	STRAIN RELIEF
4	MAP-60-07	1	WASHER, RUBBER
5	MAP-60-10	1	NUT, OM ADAPTER

B MAJ-60-50

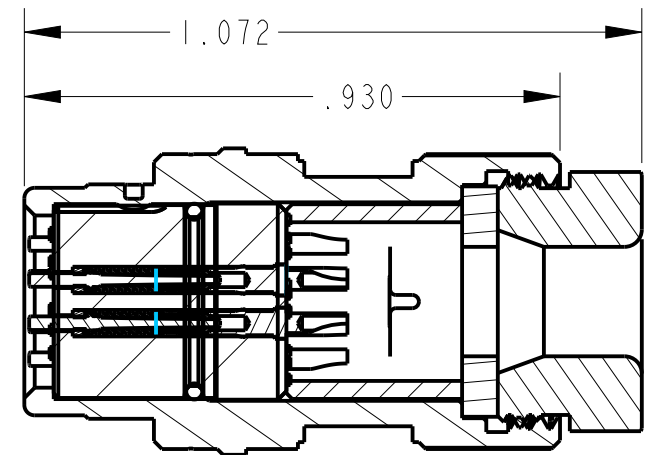

SECTION Z-Z

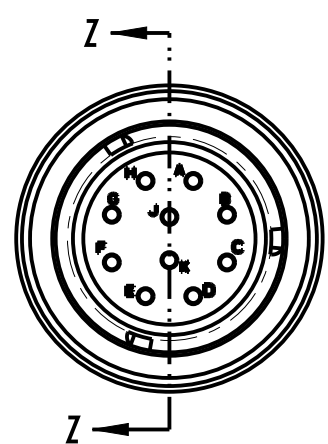
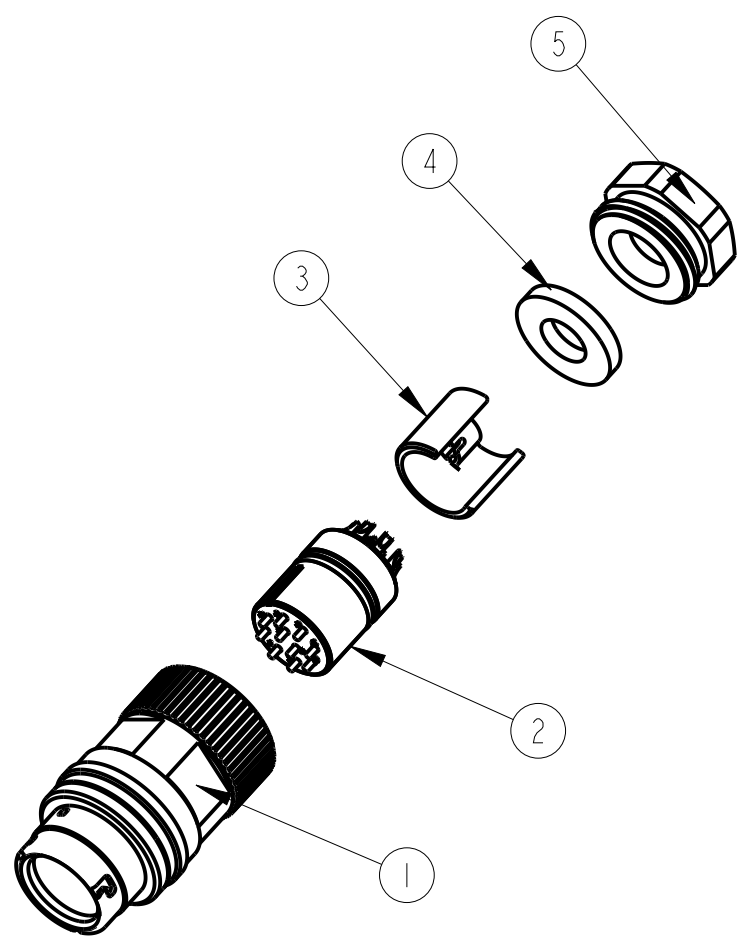
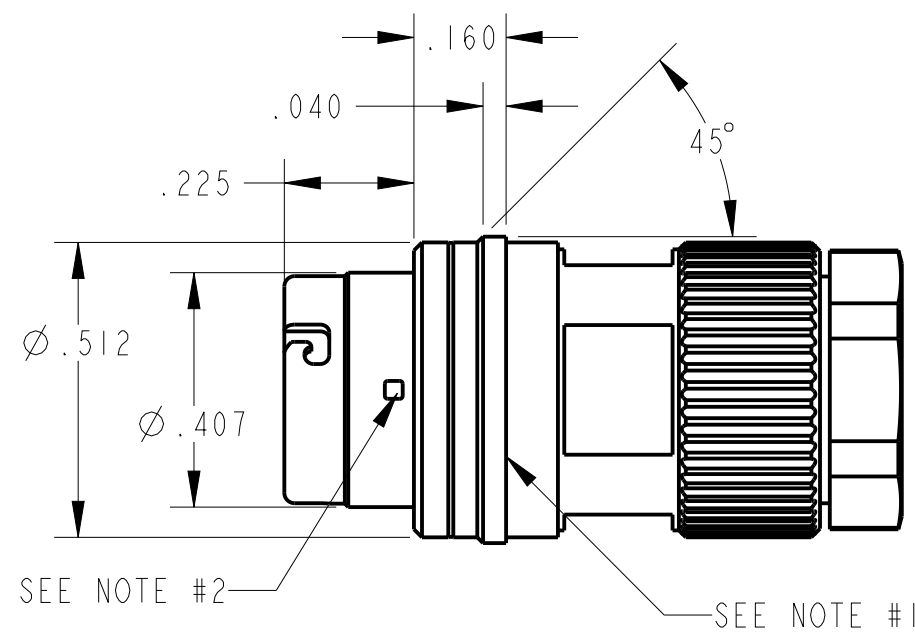
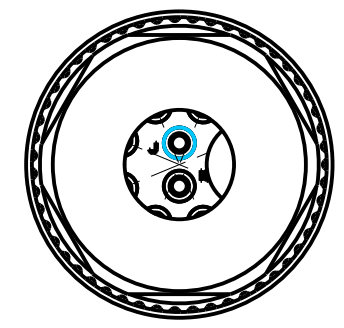

THIS DOCUMENT CONTAINS PROPRIETARY INFORMATION OF NEXUS, INCORPORATED AND SUCH INFORMATION MAY NOT BE DISCLOSED TO OTHERS FOR ANY PURPOSE OR USED FOR ANY PURPOSE WITHOUT THE WRITTEN CONSENT OF NEXUS.

NOTES:
 1) OVERMOLD SHUTOFF SURFACE
 2) ORANGE ALIGNMENT DIMPLE

DWN. BY	DATE	MATERIAL		
CHECKED BY	DATE	FINISH		
APPR. BY	DATE	WEIGHT	SCALE = 2.00 : 1	
UNLESS OTHERWISE SPECIFIED: DIMENSIONS ARE IN INCHES &/OR [mm]		TITLE		
TOLERANCES:		10-COND OM RECEPTACLE		
DECIMAL: .XX[X.X] .XXX[X.XX]		Ø .185 CABLE		
FRACTION: X/X ±1/64		DO NOT SCALE DWG. SHEET 1 OF 1		
ANGLES: .X ±.5°		NEXUS STAMFORD, CONN		
LET. REVISION		SIZE	DWG. NO.	
B	REPLACE CONTACT INSERT WAS MAJ-60-01	B	MAJ-60-50	
A	NEW RELEASE			

LET.	REVISION	CN #	DATE	CHK.
B	REPLACE CONTACT INSERT WAS MAJ-60-01	1259	10/14 2019	BAM
A	NEW RELEASE		8/15 2011	HR