

**SERIES:** PSE-1000 | **DESCRIPTION:** AC-DC HOT-SWAP POWER SUPPLY

**FEATURES**

- up to 1000 W continuous power
- 1U x 2U package
- I<sup>2</sup>C communication for monitoring and control
- blind mate connections for hot-swap
- redundant (N+1) operation
- power factor correction
- 3.3 Vdc (0.5A) standby voltage
- DROOP current sharing or forced current sharing (optional)
- single I/O connector for AC input, DC output & signals
- remote on/off control, power good signal
- efficiency up to 90%



MODEL	output voltage	output current max	output power max	ripple and noise max	efficiency <sup>1</sup>
	(Vdc)	(A)	(W)	(mVp-p)	typ (%)
PSE-1000-54	54	18.50	1000	540	90

Notes: 1. At 230 Vac input.

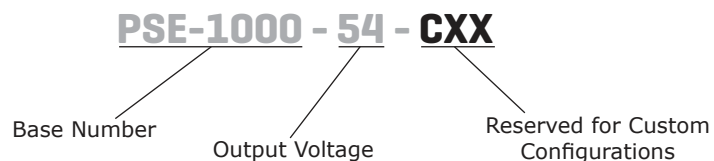
**PART NUMBER KEY**

## INPUT

parameter	conditions/description	min	typ	max	units
voltage		90		264	Vac
frequency		50		60	Hz
current	at 90 Vac			13.2	A
inrush current	half cycle, cold start, 25°C at 115 Vac, 60 Hz at 230 Vac, 50 Hz			20 40	A A
leakage current				1.5	mArms
power factor correction		0.95	0.98		

## OUTPUT - V1 (MAIN OUTPUT)

parameter	conditions/description	min	typ	max	units
total regulation			±3		%
transient response	25% step load, recovery to 1% within 1 ms, slew rate 1 A/μs			3	%
hold-up time	full load in redundant operation	12 20			ms ms

## OUTPUT - V2 (STANDBY OUTPUT)

parameter	conditions/description	min	typ	max	units
output voltage			3.3		Vdc
output current		0		0.5	A
ripple and noise				33	mVp-p
total regulation			±2.5		%

## STATUS & CONTROL

parameter	conditions/description	min	typ	max	units
I <sup>2</sup> C interface	SCL 100 kHz clock rate, SDA data line				
remote sense	main output				
remote enable	"active low" enable main output, last-mate/ first-break enable pin				
current share	droop share, active current share option				
status	AC OK, DC OK, and OTP_OK (open collector, active "low" =OK); and PS_Present				
LED indicator	AC OK & DC OK indicators				

## PROTECTIONS

parameter	conditions/description	min	typ	max	units
over voltage protection	V1 V2		115	60	Vdc %
over current protection	latching; shutdown after 2 s			120	%
over temperature protection	output shut down, auto recovery				

## SAFETY & COMPLIANCE

parameter	conditions/description	min	typ	max	units
safety approvals	cTUVus UL60950-1, CE (LVD)				
emissions	FCC 15 Sub Part J, Class A, EN55022 Class A				
harmonic compliance	EN61000-3-2 Class A				
surges (mains)	IEC/EN 61000-4-5				
voltage dips/interruptions	IEC/EN 61000-4-11				

**SAFETY & COMPLIANCE (CONTINUED)**

parameter	conditions/description	min	typ	max	units
MTBF	as per Telcordia SR332, 40°C, full load	500,000			hours
RoHS	2011/65/EU				

**ENVIRONMENTAL**

parameter	conditions/description	min	typ	max	units
operating temperature		0		55	°C
storage temperature		-40		85	°C

**MECHANICAL**

parameter	conditions/description	min	typ	max	units
dimensions	10.00 x 3.30 x 1.60 (254.0 x 83.8 x 40.6 mm)				inches
cooling / airflow	integral high performance 38 mm fan air inlet at face; exhaust at connector				
input / output connector	FCI P/N 51939-420LF mates with FCI P/N 51762-10602000AALF				
hot-swap capability	fully hot-swappable, blind mate connector				

**MECHANICAL DRAWING**

units: inches [mm]  
tolerance:  
X.XX ±0.02 [0.50]  
X.XXX ±0.010 [0.25]

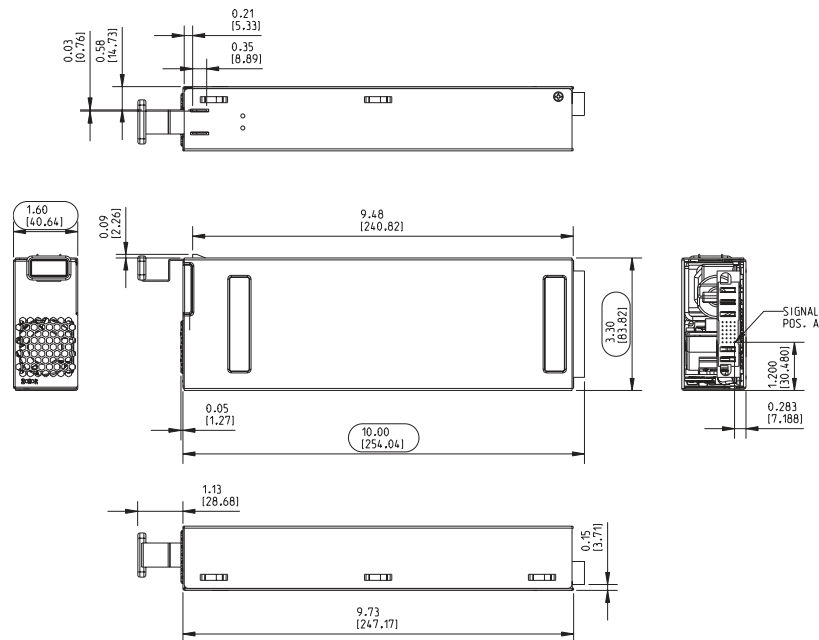
**INPUT / OUTPUT CONNECTOR**

Pins	Function	Pins	Function	Pins	Function	Pins	Function	Pins	Function	Pins	Function	Pins	Function
P1	+54 V	A1	+V1 Sense	A2	EEPROM A0	A3 <sup>1</sup>	N/C	A4	AC OK	A5	Signal Return	A6	+3.3 VSB Return
P2	-54 V	B1	-V1 Sense	B2	EEPROM A1	B3 <sup>1</sup>	N/C	B4	DC OK	B5	EEPROM Clock SCL	B6	+3.3 VSB Adj.
P3	FG	C1	ISHARE	C2	EEPROM A2	C3 <sup>1</sup>	N/C	C4	PS_PRESENT	C5	EEPROM Data (SDA)	C6	Spare
P4	AC Neutral	D1	V Program	D2	N/C	D3 <sup>1</sup>	N/C	D4	OTP OK	D5	+3.3 VSB	D6	Enable (short pin)
P5	AC Line	--	--	--	--	--	--	--	--	--	--	--	--

Note: 1. POE Isolation Barrier - No traces to be routed between these pins and any others.

## REVISION HISTORY

---

rev.	description	date
1.0	initial release	05/06/2015
1.01	updated datasheet	06/10/2016

The revision history provided is for informational purposes only and is believed to be accurate.



**Headquarters**  
20050 SW 112th Ave.  
Tualatin, OR 97062  
**800.275.4899**

Fax 503.612.2383  
**cui.com**  
techsupport@cui.com

CUI offers a two (2) year limited warranty. Complete warranty information is listed on our website.

CUI reserves the right to make changes to the product at any time without notice. Information provided by CUI is believed to be accurate and reliable. However, no responsibility is assumed by CUI for its use, nor for any infringements of patents or other rights of third parties which may result from its use.

CUI products are not authorized or warranted for use as critical components in equipment that requires an extremely high level of reliability. A critical component is any component of a life support device or system whose failure to perform can be reasonably expected to cause the failure of the life support device or system, or to affect its safety or effectiveness.