

IsoLoop[®]
**RS-485 Narrow-Body Isolated
Transceiver Evaluation Board**

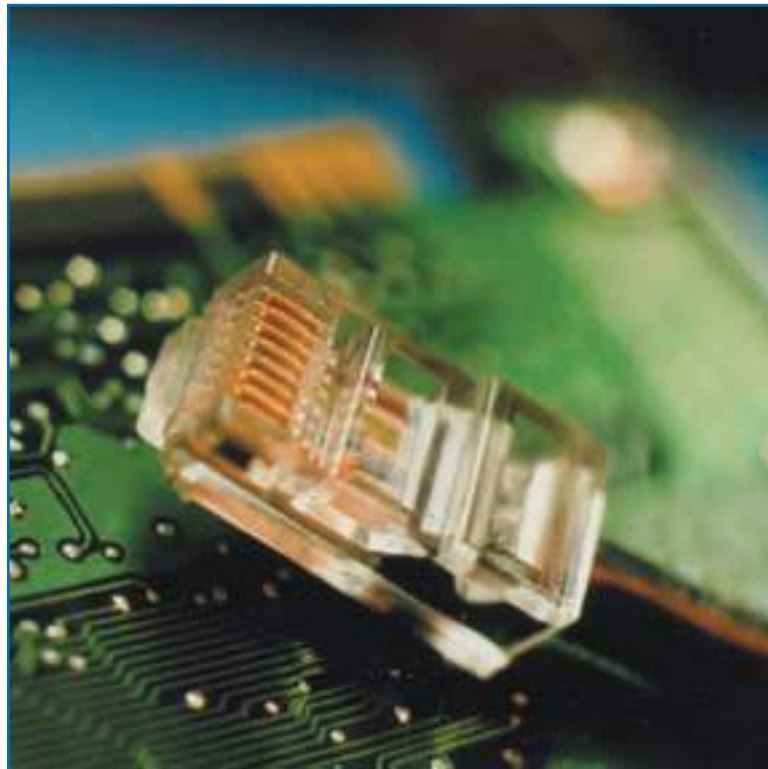

Board No.: IL3585-3-01

About This Evaluation Board

Isolation reduces noise, eliminates ground loops, and improves safety.

The RS-485 Evaluation Board provides a complete isolated RS-485 node using the ultraminiature IL3585-3E narrow-body isolated transceiver.

The evaluation board provides screw terminal and RJ45 connections, and demonstrates best layout practices including separate ground planes.

Termination, pull-up, and pull-down resistors can be changed to accommodate different fanouts and termination methods.

IL3585 transceivers deliver an exceptional 2.3 V differential output into a 54 Ω load and data rates to 40 Mbps. The device is also compatible with 3.3 V input supplies for interface to standard microcontrollers without additional level shifting.

IL3585-3E Specification Highlights

- 40 Mbps data rate
- 16-pin narrow-body (0.15-inch) SOIC package
- 3 V to 5.5 V power supplies
- 20 ns propagation delay
- 5 ns pulse skew
- 100 ps jitter
- Low quiescent supply current
- 2,500 V_{RMS} isolation (1 minute)
- 20 kV/ μ s transient immunity
- 15 kV bus ESD protection
- Low EMC footprint
- Thermal shutdown protection
- -40°C to +85°C temperature range
- Meets or exceeds ANSI RS-485 and ISO 8482:1987(E)
- UL 1577 recognized and IEC 61010-2001 approved

Visit www.IsoLoop.com for datasheets and illustrative applications.

Evaluation Board Layout

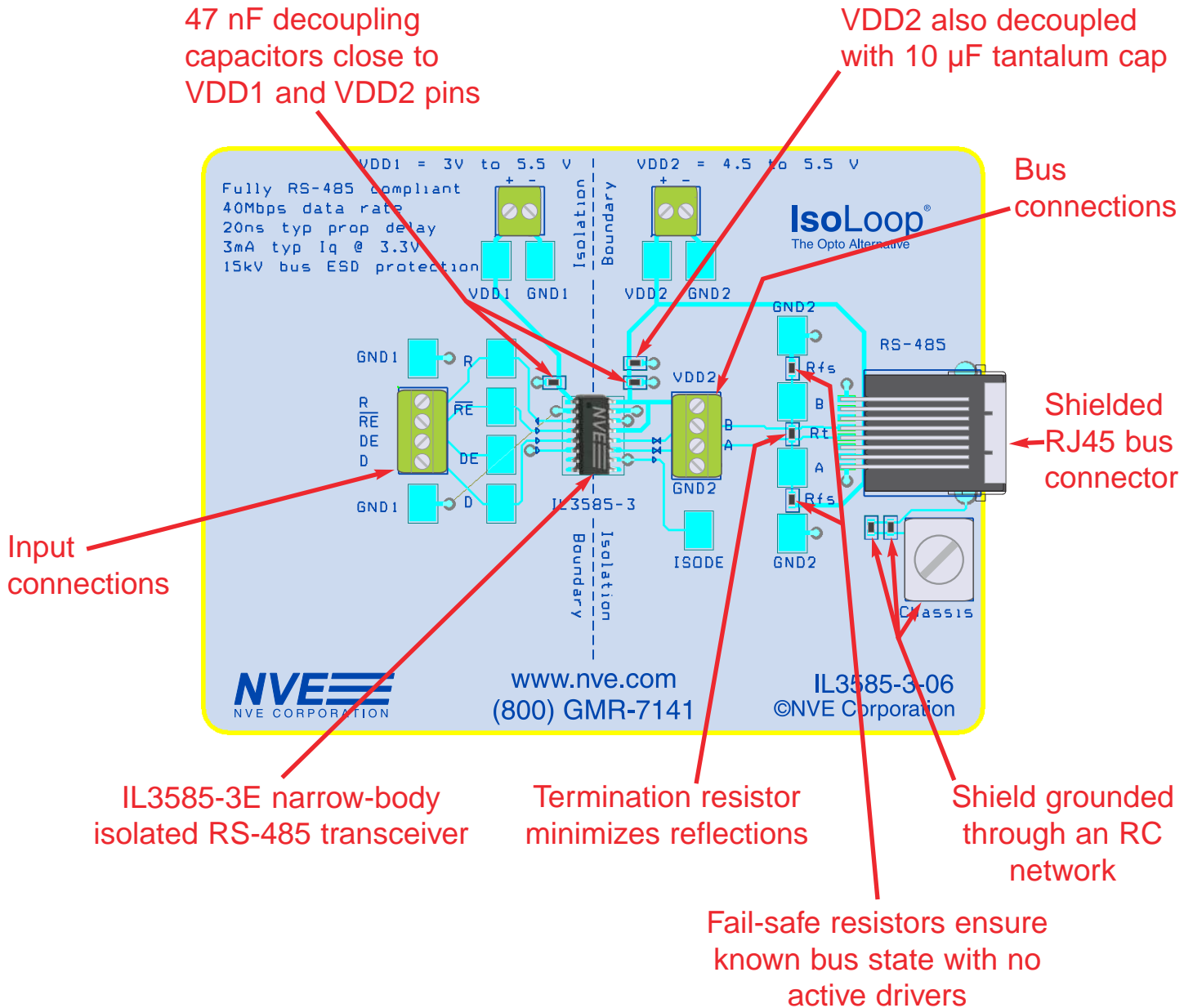

Quick Start

- Connect V_{DD1} to a 3.3 V power supply and V_{DD2} to a 5 V supply.
- Tie “DE” high and “ \overline{RE} ” low to enable the input and output data.
- Connect a signal generator to the “D” input.
- Look for the complementary “A” and “B” outputs on an oscilloscope.

Circuit Diagram

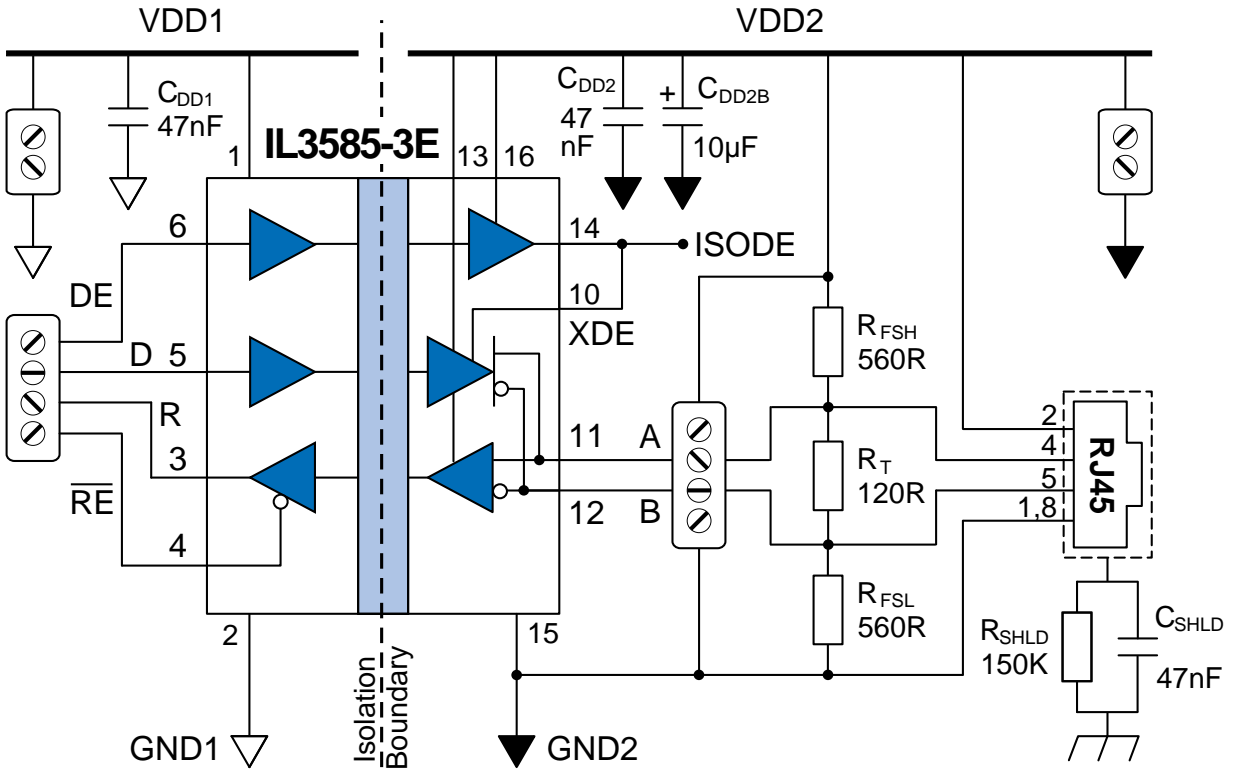

IL3585-3E pin	Symbol	Description
1	VDD1	Input power supply
2	GND1	Input power supply ground return
3	R	Output data from bus
4	\overline{RE}	Read data enable (R=high impedance if RE is high)
5	D	Data input to bus
6	DE	Drive enable
7	NC	No internal connection
8	NC	No internal connection
9	NC	No internal connection
10	XDE	Transceiver Device Enable (normally connected to pin 14)
11	A	Non-inverting bus line
12	B	Inverting bus line
13	VDD2X	Output transceiver power supply (normally connected to pin 16)
14	ISODE	Isolated DE output (normally connected to pin 10)
15	GND2	Output power supply ground return
16	VDD2I	Output power supply (normally connected to pin 13)

Cables, Connectors, and Bus Topology

Cable Length

IL3585 transceivers are intended for networks up to 4,000 feet (1,200 m), although the maximum data rate decreases as cable length increases.

Cables and Connectors

Twisted pair cable helps cancel common mode noise. In noisy environments, use Shielded Twisted Pair (STP) CAT5 or CAT6 cables and shielded connectors. With shielded cables, one of the connectors should be tied to earth ground (not digital ground). For demanding applications, the other connector shield should be connected via an R-C network (typically 47 nF in parallel with 150 k Ω) to earth ground to damp AC noise induced in the shield.

Connector Board Layout Best Practices

Although not always necessary, the following connector layout precautions are best practices:

- The connector, termination resistor, and transceiver should be as close together as possible.
- Two wires from the same differential pair should be adjacent on the connector.
- A differential microstrip on the board reduces reflections if long traces are necessary.
- Use 47 nF decoupling capacitors as close as possible to transceiver V_{DD} pins, plus 10 μ F on V_{DD2} .
- Provide ground planes for both power supplies.

Network Topologies and Spurs

Configurations C and D below are examples of ideal configurations where the nodes are in a continuous line, although not necessarily straight:

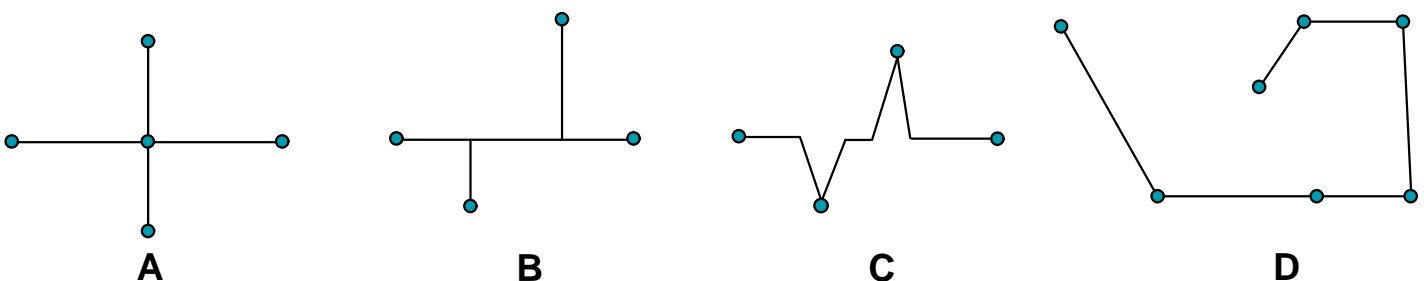

Configurations A and B have long spurs that can cause reflections. Short spurs from the bus to intermediate nodes are generally necessary, however. If so, stub lengths should be less than one-sixth the electrical signal length, which is defined as:

$$\text{Electrical Length} = t_r / (\text{Propagation Delay})$$

For typical values of 10 nanoseconds rise time and 78% propagation velocity, we get an electrical signal length of 2.3 meters. Thus the maximum stub length is one-sixth of the electrical length, or 39 cm.

Biasing and Termination

Inherent Fail-Safe Biasing

“Fail-safe biasing” forces a logic high state on “R” in response to an open-circuit condition between the bus “A” and “B” lines, or when no drivers are active on the bus. IL3000-Series Isolated Transceivers include internal pull-up and pull-down resistors of approximately 30 kΩ in the receiver section (R_{FS-INT} in the figure at right). These internal resistors ensure fail-safe operation if there are no termination resistors and up to four RS-485 worst-case Unit Loads of 12 kΩ.

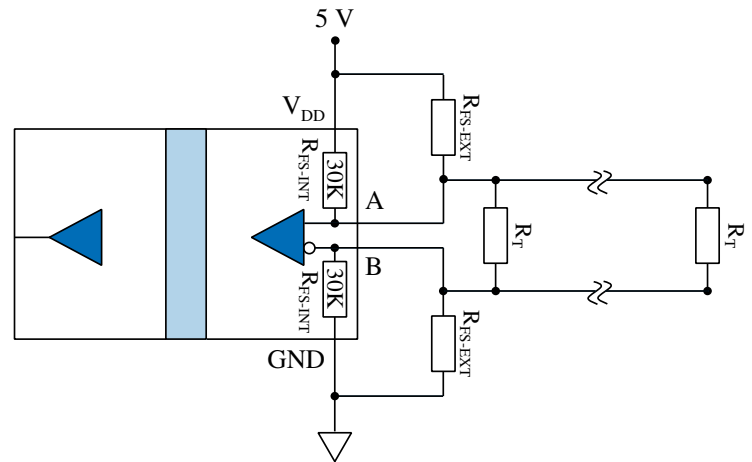

Terminate Most Networks

Below 1 Mbps or less than 1,000 feet (300 m), some networks can be unterminated, but reflections cause errors in faster or longer networks. Reflections are minimized by terminating both ends of the bus (but not every node). Two 120 Ω termination resistors are generally used to match a 60 Ω cable impedance.

External Fail-Safe Biasing Resistors

With termination, the differential voltage across the conductor pair will be close to zero with no active drivers. In this case, the idle bus is indeterminate and susceptible to noise. External fail-safe biasing resistors (R_{FS-EXT}) at one end of the bus ensure fail-safe operation with a terminated bus. Biasing should provide at least 200 mV across the conductor pair to meet the RS-485 input sensitivity specification.

The more loads on the bus, the lower the required values of the biasing resistors. The evaluation board has a 120 Ω termination resistor and 560 Ω biasing resistors for fail-safe operation for up to four Unit Loads.

The following table shows other examples:

R_{FS-EXT}	R_T	Loading	Nominal V_{A-B} (inactive)
Internal Only	None	Four unit loads (12 kΩ ea.)	238 mV
Internal Only	120 Ω	Four unit loads (12 kΩ ea.)	5 mV
560 Ω	120 Ω	Four unit loads (12 kΩ ea.)	254 mV
510 Ω	120 Ω	32 unit loads (12 kΩ ea.)	247 mV

Isolated Network Transceivers

NVE offers a wide choice of isolated RS-422, RS-485, and CAN network transceivers. Models provide high speed, 15 kV ESD protection, handshake channels, and fractional loads.

Versions are available in 0.15-inch and 0.3-inch SOIC packages, making these the most compact solutions in the world while still meeting safety standard creepage and clearance requirements.

All transceivers have an isolation rating of 2,500 V_{RMS} (one minute), and are supplied RoHS compliant as standard. All are UL1577 and IEC61010 approved; the IL3685 is PROFIBUS compliant.

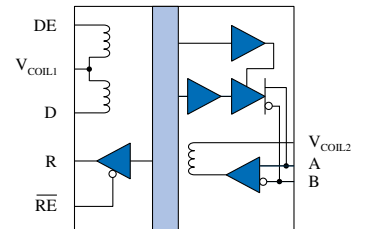
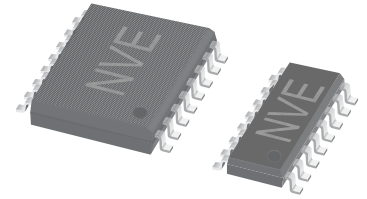

**IL3122/IL3185/
IL3222/IL3285/
IL3422/IL3485**

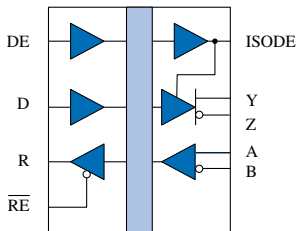

IL422/IL485

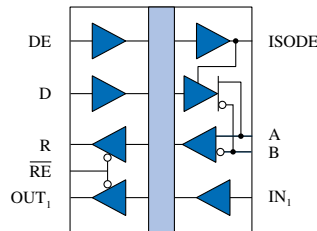

IL485W

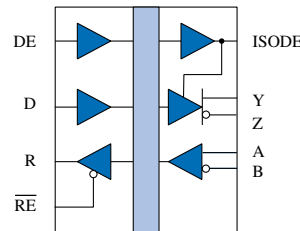

IL3522/IL3585

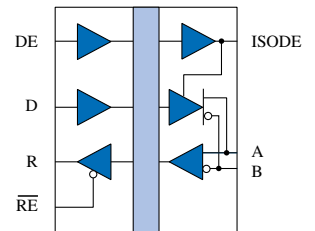

IL3685

Model	Bus	Inputs	Mbps	Nodes	Bus ESD (kV)	Key Features	Packages
IL3122	RS-422	Passive	5	32	15	Low Cost	0.15" SOIC-16; 0.3" SOIC-16
IL3185	RS-485	Passive	5	32	15	Low Cost	0.15" SOIC-16; 0.3" SOIC-16
IL3222	RS-422	Passive	5	256	15	Fractional Load	0.15" SOIC-16; 0.3" SOIC-16
IL3285	RS-485	Passive	5	256	15	Fractional Load	0.15" SOIC-16; 0.3" SOIC-16
IL3422	RS-422	Passive	20	32	15	High Speed	0.15" SOIC-16; 0.3" SOIC-16
IL3485	RS-485	Passive	20	32	15	High Speed	0.15" SOIC-16; 0.3" SOIC-16
IL422	RS-422	Digital	25	32	15	Industry Standard	0.3" SOIC-16
IL485	RS-485	Digital	35	32	2	Industry Standard	0.3" SOIC-16
IL485W	RS-485	Digital	35	32	2	RS-485 + Handshake	0.3" SOIC-16
IL3522	RS-422	Digital	40	50	15	Very High Speed	0.3" SOIC-16
IL3585	RS-485	Digital	40	50	15	Very High Speed	0.15" SOIC-16; 0.3" SOIC-16
IL3685	RS-485	Digital	40	50	15	PROFIBUS Compliant	0.15" SOIC-16; 0.3" SOIC-16

Limited Warranty and Liability

Information in this document is believed to be accurate and reliable. However, NVE does not give any representations or warranties, expressed or implied, as to the accuracy or completeness of such information and shall have no liability for the consequences of use of such information. In no event shall NVE be liable for any indirect, incidental, punitive, special or consequential damages (including, without limitation, lost profits, lost savings, business interruption, costs related to the removal or replacement of any products or rework charges) whether or not such damages are based on tort (including negligence), warranty, breach of contract or any other legal theory.

Right to Make Changes

NVE reserves the right to make changes to information published in this document including, without limitation, specifications and product descriptions at any time and without notice.

Use in Life-Critical or Safety-Critical Applications

Unless NVE and a customer explicitly agree otherwise in writing, NVE products are not designed, authorized or warranted to be suitable for use in life support, life-critical or safety-critical devices or equipment. NVE accepts no liability for inclusion or use of NVE products in such applications and such inclusion or use is at the customer's own risk. Should the customer use NVE products for such application whether authorized by NVE or not, the customer shall indemnify and hold NVE harmless against all claims and damages.

Applications

Applications described in this document are illustrative only. NVE makes no representation or warranty that such applications will be suitable for the specified use without further testing or modification. Customers are responsible for the design and operation of their applications and products using NVE products, and NVE accepts no liability for any assistance with applications or customer product design. It is customer's sole responsibility to determine whether the NVE product is suitable and fit for the customer's applications and products planned, as well as for the planned application and use of customer's third party customers. Customers should provide appropriate design and operating safeguards to minimize the risks associated with their applications and products. NVE does not accept any liability related to any default, damage, costs or problem which is based on any weakness or default in the customer's applications or products, or the application or use by customer's third party customers. The customer is responsible for all necessary testing for the customer's applications and products using NVE products in order to avoid a default of the applications and the products or of the application or use by customer's third party customers. NVE accepts no liability in this respect.

An ISO 9001 Certified Company

NVE Corporation
11409 Valley View Road
Eden Prairie, MN 55344-3617

©NVE Corporation

All rights are reserved. Reproduction in whole or in part is prohibited without the prior written consent of the copyright owner.

Manual No.: ISB-CB-008

December 2012