

NOTES:

1. HOUSING MAT'L.: POLYESTER, UNFILLED, 94V-0. COLOR: BLACK. TERMINAL MATERIAL: BRASS ALLOY.
2. PLATINGS:
 - 2 = .000030/(.00076) MIN. SELECT GOLD AND .000100/(.00254) MIN. SELECT MATTE TIN OVER .000050/(.00127) MIN. NICKEL OVERALL.
 - 3 = .000100/(0.00254) MIN. BRIGHT TIN OVER .000050/(0.00127) MIN. NICKEL OVERALL.
3. PRODUCT SPECIFICATION: PS-5556-003.
4. PACKAGING SPECIFICATION: BULK PER PK-30069-001. TRAY PER 30069000-PK
5. PART MATES WITH RECEPTACLE 30067-*.
 - △ FLANGE MOUNT PART IS DESIGNED FOR USE WITH #4 OR M3 SELF TAPPING SCREWS.
 - △ SEE CHART ON SHEET 3 FOR STD. TERMINAL, GROUNDING TERMINAL AND VOID LOCATIONS.
8. PARTS ARE NOT TO BE MATED OR UNMATED WHILE CIRCUITS ARE LIVE.
9. ITEM NUMBERS PRECEDED BY AN 'X' IN THE CHART ON SHEET 3 ARE NOT AVAILABLE.
10. PART CONFORMS TO CLASS 'B' REQUIREMENTS OF COSMETIC SPECIFICATION PS-45499-002.

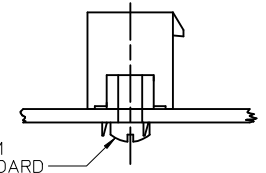

△ INSTALL SCREW FROM UNDERSIDE OF P.C. BOARD
RECOMMENDED INSTALLATION OF HEADER TO P.C. BOARD

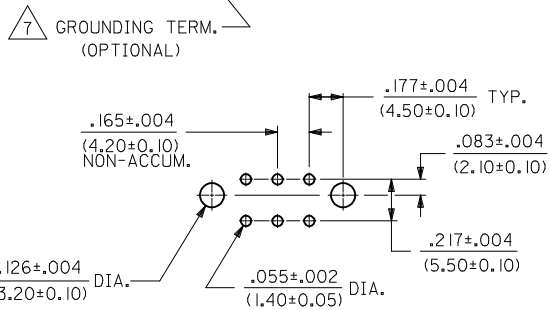
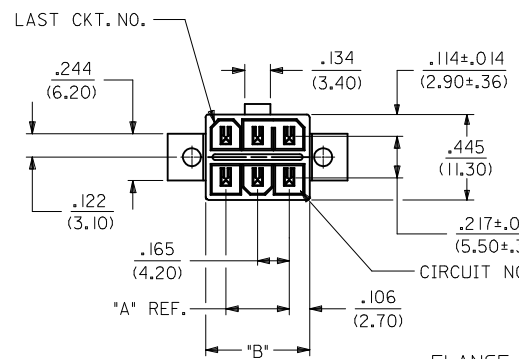
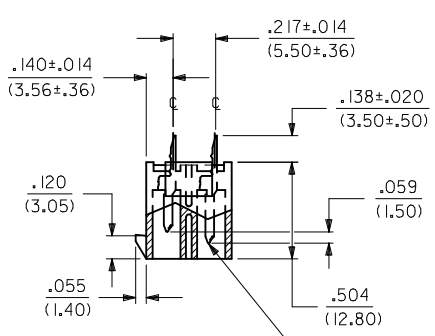
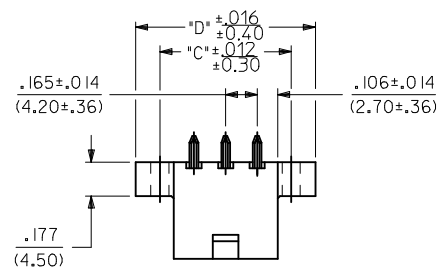

FLANGE MOUNT
RECOMMENDED HOLE LAYOUT FOR .070/(1.78) MAX. THICK P.C. BOARD

△ 7 GROUNDING TERM. (OPTIONAL)

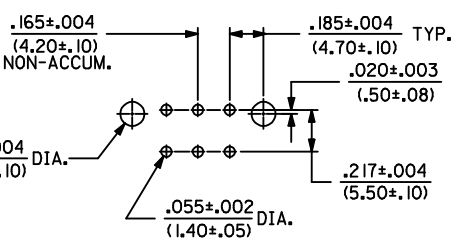
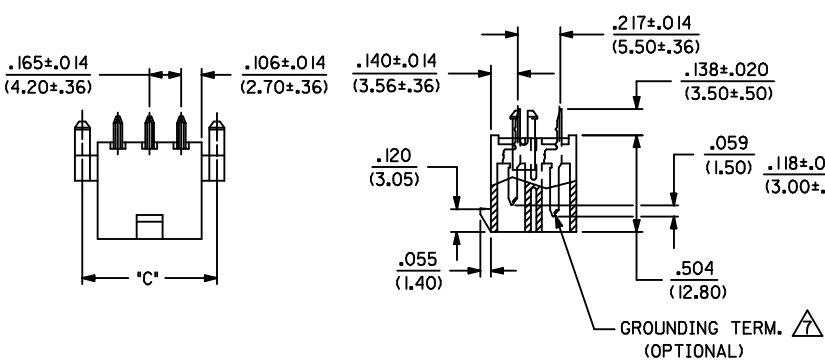

WITH PEGS
RECOMMENDED HOLE LAYOUT FOR .070/(1.78) MAX. THICK P.C. BOARD

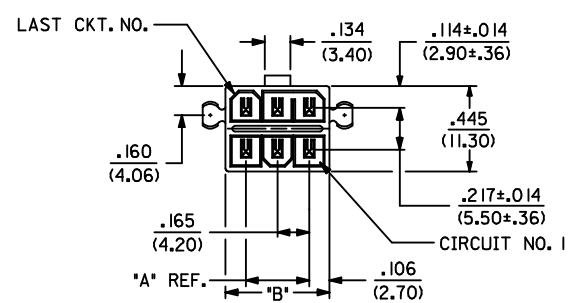

WITH PEGS

CKT. SIZE	LETTER DIMENSIONS FOR ASSEMBLIES WITH PEGS		
	DIM. 'A'	DIM. 'B'	DIM. 'C'
2	—	.213 (5.40)	.370 (9.40)
4	.165 (4.20)	.378 (9.60)	.535 (13.60)
6	.331 (8.40)	.543 (13.80)	.701 (17.80)
8	.496 (12.60)	.709 (18.00)	.866 (22.00)
10	.661 (16.80)	.874 (22.20)	1.031 (26.20)
12	.827 (21.00)	1.039 (26.40)	1.197 (30.40)
14	.992 (25.20)	1.205 (30.60)	1.362 (34.60)
16	1.157 (29.40)	1.370 (34.80)	1.528 (38.80)

CKT. SIZE	LETTER DIMENSIONS FOR ASSEMBLIES WITH FLANGES			
	DIM. 'A'	DIM. 'B'	DIM. 'C'	DIM. 'D'
2	—	.213 (5.40)	.354 (9.00)	.606 (15.40)
4	.165 (4.20)	.378 (9.60)	.520 (13.20)	.772 (19.60)
6	.331 (8.40)	.543 (13.80)	.685 (17.40)	.937 (23.80)
8	.496 (12.60)	.709 (18.00)	.850 (21.60)	1.102 (28.00)
10	.661 (16.80)	.874 (22.20)	1.016 (25.80)	1.268 (32.20)
12	.827 (21.00)	1.039 (26.40)	1.181 (30.00)	1.433 (36.40)
14	.992 (25.20)	1.205 (30.60)	1.346 (34.20)	1.598 (40.60)
16	1.157 (29.40)	1.370 (34.80)	1.512 (38.40)	1.764 (44.80)

ADD TOL TO DIM D EC NO: UCP2017-2158 DRWING:APPELDORN 2017/03/31 CHKD:JBELL 2017/03/31 APPR:FSMITH 2017/04/04	QUALITY SYMBOLS ∇=0 ∇=0 ∇=0	GENERAL TOLERANCES (UNLESS SPECIFIED)	DIMENSION STYLE IN/MM	SCALE 2:1	DESIGN UNITS METRIC	THIRD ANGLE PROJECTION												
		<table border="1"> <tr> <th>mm</th> <th>INCH</th> </tr> <tr> <td>4 PLACES ± ---</td> <td>± ---</td> </tr> <tr> <td>3 PLACES ± ---</td> <td>± .010</td> </tr> <tr> <td>2 PLACES ± 0.25</td> <td>± .014</td> </tr> <tr> <td>1 PLACE ± 0.36</td> <td>± ---</td> </tr> <tr> <td>0 PLACE ±</td> <td>±</td> </tr> </table>	mm	INCH	4 PLACES ± ---	± ---	3 PLACES ± ---	± .010	2 PLACES ± 0.25	± .014	1 PLACE ± 0.36	± ---	0 PLACE ±	±	DRAWN BY: GEP DATE: 1994/07/28 CHECKED BY: RJF DATE: 1994/07/28 APPROVED BY: FSMITH DATE: 2011/02/11	VERT. HEADER ASSY., SELECTIVELY LOADED, MINI-FIT T.P.A. SERIES molex		
		mm	INCH															
		4 PLACES ± ---	± ---															
3 PLACES ± ---	± .010																	
2 PLACES ± 0.25	± .014																	
1 PLACE ± 0.36	± ---																	
0 PLACE ±	±																	
ANGULAR ±1/2° DRAFT WHERE APPLICABLE MUST REMAIN WITHIN DIMENSIONS		MATERIAL NO. SEE CHART	DOCUMENT NO. SDA-44482-****	SHEET NO. 1 OF 2														
THIS DRAWING CONTAINS INFORMATION THAT IS PROPRIETARY TO MOLEX INCORPORATED AND SHOULD NOT BE USED WITHOUT WRITTEN PERMISSION																		

ITEM NO.	CHARACTERISTIC DESCRIPTION	TERMINAL VERSION REQUIRED AT EACH CIRCUIT LOCATION: (SEE CODES AT RIGHT)																PACKAGING
		1	2	3	4	5	6	7	8	9	10	11	12	13	14	15	16	
44482-0001	I2A12	2	2	2	4	2	2	2	2	2	2	-	2	2				BULK
X 44482-0002	I2A22	2	2	2	4	2	2	2	2	2	2	2	2	2				BULK
																		BULK
44482-0004	12A12	2	2	2	4	2	2	2	2	2	2	2	-				BULK	
44482-0005	12A12	2	2	2	4	2	2	2	2	2	2	-	2	-			BULK	
44482-0006	16A13	5	5	5	-	5	5	5	5	5	5	5	5	5	5	5	BULK	
44482-0007	16A13	5	5	5	5	5	5	5	5	5	5	-	5	5	5	5	BULK	
44482-0008	12A12	2	-	2	2	2	2	2	2	2	2	2	2				BULK	
44482-0009	12A12	2	2	2	4	-	2	2	2	2	-	2	-				BULK	
44482-9901	12A12	2	2	2	4	2	2	2	2	2	-	2	2				BULK	

TERM. I.D. CODES FOR CHART AT LEFT	
TERMINAL TYPE	PLATING (NOTE 2)
"-" = VOID LOC.	N/A
"2" = STD. TERM., SELECT. GOLD	2
"4" = GROUNDING TERM., SELECT. GOLD	2
"5" = STD. TERM, TIN	3
"6" = STD. GROUNDING TERM, TIN	3

SEE NOTE 9

CHARACTERISTICS LEGEND:

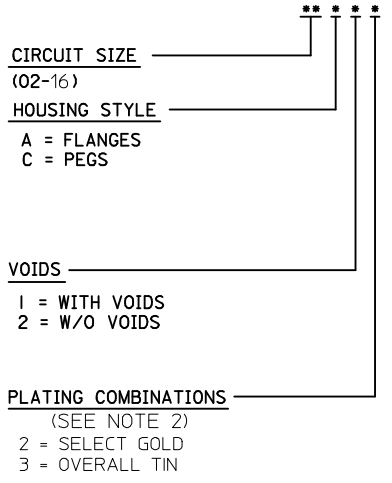

SEE SHEET 1 EC NO: UCP2017-2158 DRWN: BAPPELDORN 2017/03/31 CHKD: JBELL 2017/03/31 APPR: FSMITH 2017/04/04	QUALITY SYMBOLS	GENERAL TOLERANCES (UNLESS SPECIFIED)	DIMENSION STYLE	SCALE	DESIGN UNITS	THIRD ANGLE PROJECTION
	▽=0	mm INCH	IN/MM		METRIC	
	▽=0	4 PLACES ± --- ± ---	DRAWN BY DATE	TITLE		
	▽=0	3 PLACES ± --- ± .010	CHECKED BY DATE			
	2 PLACES ± 0.25 ± .014	APPROVED BY DATE				
	1 PLACE ± 0.36 ± ---	FSMITH 2011/02/11				
	0 PLACE ± ±					
	ANGULAR ±1/2°	MATERIAL NO.	DOCUMENT NO.			
	DRAFT WHERE APPLICABLE MUST REMAIN WITHIN DIMENSIONS	SEE CHART	SDA-44482-****			
		SIZE C	THIS DRAWING CONTAINS INFORMATION THAT IS PROPRIETARY TO MOLEX INCORPORATED AND SHOULD NOT BE USED WITHOUT WRITTEN PERMISSION			

VERT. HEADER ASSY.,
SELECTIVELY LOADED,
MINI-FIT T.P.A. SERIES

molex

NOTES:

- HOUSING MAT'L.: POLYESTER, UNFILLED, 94V-0. COLOR: BLACK. TERMINAL MATERIAL: BRASS ALLOY.
 - PLATINGS:
 - = .000030/(.00076) MIN. SELECT GOLD AND .000100/(.00254) MIN. SELECT MATTE TIN OVER .000050/(.00127) MIN. NICKEL OVERALL.
 - = .000100/(0.00254) MIN. BRIGHT TIN OVER .000050/(0.00127) MIN. NICKEL OVERALL.
 - PRODUCT SPECIFICATION: PS-5556-003.
 - PACKAGING SPECIFICATION: BULK PER PK-30069-001.
- TRAY PER 30069000-PK
- PART MATES WITH RECEPTACLE 30067-*,
- ⚠️ FLANGE MOUNT PART IS DESIGNED FOR USE WITH #4 OR M3 SELF TAPPING SCREWS.
- ⚠️ SEE CHART ON SHEET 3 FOR STD. TERMINAL, GROUNDING TERMINAL AND VOID LOCATIONS.
- PARTS ARE NOT TO BE MATED OR UNMATED WHILE CIRCUITS ARE LIVE.
 - ITEM NUMBERS PRECEDED BY AN 'X' IN THE CHART ON SHEET 3 ARE NOT AVAILABLE.
 - PART CONFORMS TO CLASS 'B' REQUIREMENTS OF COSMETIC SPECIFICATION PS-45499-002.

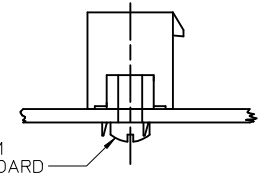

INSTALL SCREW FROM UNDERSIDE OF P.C. BOARD
RECOMMENDED INSTALLATION OF HEADER TO P.C. BOARD

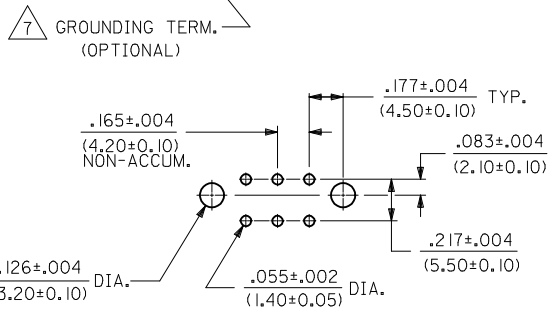
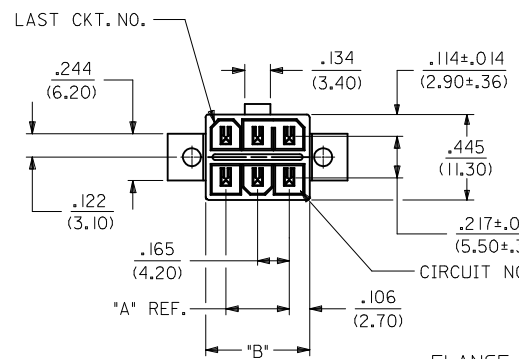
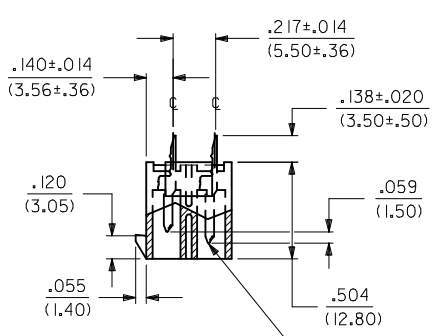
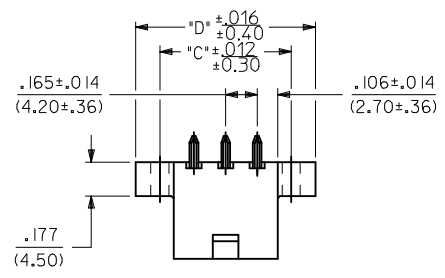

FLANGE MOUNT

RECOMMENDED HOLE LAYOUT FOR .070/(1.78) MAX. THICK P.C. BOARD

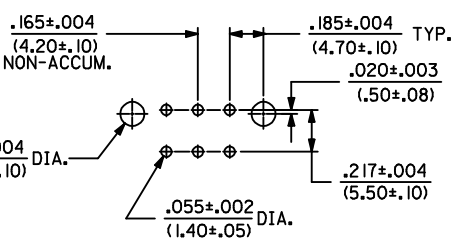
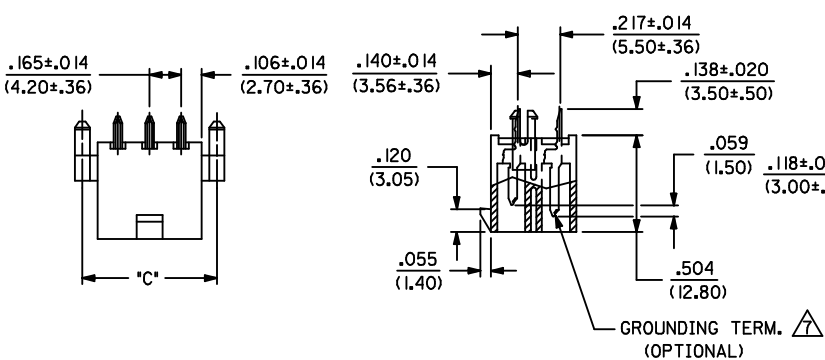

WITH PEGS

RECOMMENDED HOLE LAYOUT FOR .070/(1.78) MAX. THICK P.C. BOARD

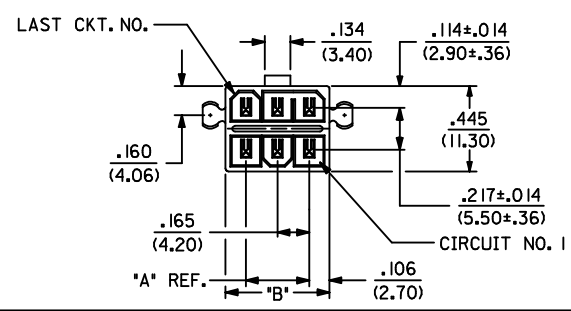

CKT. SIZE	LETTER DIMENSIONS FOR ASSEMBLIES WITH PEGS		
	DIM. 'A'	DIM. 'B'	DIM. 'C'
2	—	.213 (5.40)	.370 (9.40)
4	.165 (4.20)	.378 (9.60)	.535 (13.60)
6	.331 (8.40)	.543 (13.80)	.701 (17.80)
8	.496 (12.60)	.709 (18.00)	.866 (22.00)
10	.661 (16.80)	.874 (22.20)	1.031 (26.20)
12	.827 (21.00)	1.039 (26.40)	1.197 (30.40)
14	.992 (25.20)	1.205 (30.60)	1.362 (34.60)
16	1.157 (29.40)	1.370 (34.80)	1.528 (38.80)

CKT. SIZE	LETTER DIMENSIONS FOR ASSEMBLIES WITH FLANGES			
	DIM. 'A'	DIM. 'B'	DIM. 'C'	DIM. 'D'
2	—	.213 (5.40)	.354 (9.00)	.606 (15.40)
4	.165 (4.20)	.378 (9.60)	.520 (13.20)	.772 (19.60)
6	.331 (8.40)	.543 (13.80)	.685 (17.40)	.937 (23.80)
8	.496 (12.60)	.709 (18.00)	.850 (21.60)	1.102 (28.00)
10	.661 (16.80)	.874 (22.20)	1.016 (25.80)	1.268 (32.20)
12	.827 (21.00)	1.039 (26.40)	1.181 (30.00)	1.433 (36.40)
14	.992 (25.20)	1.205 (30.60)	1.346 (34.20)	1.598 (40.60)
16	1.157 (29.40)	1.370 (34.80)	1.512 (38.40)	1.764 (44.80)

ADD TOL TO DIM D EC NO: UCP2017-2158 DRWING:APPELDORN 2017/03/31 CHKD:JBELL 2017/03/31 APPR:FSMITH 2017/04/04	QUALITY SYMBOLS ∇=0 ∇=0 ∇=0	GENERAL TOLERANCES (UNLESS SPECIFIED)	DIMENSION STYLE IN/MM	SCALE 2:1	DESIGN UNITS METRIC	THIRD ANGLE PROJECTION												
		<table border="1"> <tr> <th>mm</th> <th>INCH</th> </tr> <tr> <td>4 PLACES ± ---</td> <td>± ---</td> </tr> <tr> <td>3 PLACES ± ---</td> <td>± .010</td> </tr> <tr> <td>2 PLACES ± 0.25</td> <td>± .014</td> </tr> <tr> <td>1 PLACE ± 0.36</td> <td>± ---</td> </tr> <tr> <td>0 PLACE ±</td> <td>±</td> </tr> </table>	mm	INCH	4 PLACES ± ---	± ---	3 PLACES ± ---	± .010	2 PLACES ± 0.25	± .014	1 PLACE ± 0.36	± ---	0 PLACE ±	±	DRAWN BY: GEP DATE: 1994/07/28 CHECKED BY: RJF DATE: 1994/07/28 APPROVED BY: FSMITH DATE: 2011/02/11	TITLE: VERT. HEADER ASSY., SELECTIVELY LOADED, MINI-FIT T.P.A. SERIES molex DOCUMENT NO. SDA-44482-**** SHEET NO. 1 OF 2		
		mm	INCH															
		4 PLACES ± ---	± ---															
3 PLACES ± ---	± .010																	
2 PLACES ± 0.25	± .014																	
1 PLACE ± 0.36	± ---																	
0 PLACE ±	±																	
ANGULAR ±1/2° DRAFT WHERE APPLICABLE MUST REMAIN WITHIN DIMENSIONS		MATERIAL NO. SEE CHART		THIS DRAWING CONTAINS INFORMATION THAT IS PROPRIETARY TO MOLEX INCORPORATED AND SHOULD NOT BE USED WITHOUT WRITTEN PERMISSION														
F1																		

