

# IPM SERIES

007089

Issue 1

## Intelligent Particulate Matter Sensor

Honeywell Intelligent Particulate Matter sensor (IPM Series) is a laser-based sensor that detects and measures particle concentration using light scattering for monitoring air quality.

The detection concentration range is  $0 \mu\text{g}/\text{m}^3$  to  $1,000 \mu\text{g}/\text{m}^3$ . A laser light source illuminates a particle as it is pulled through the detection chamber. As particles pass through the laser beam, the light reflects off the particles and is recorded on the photo or light detector. The light is then analyzed and converted to an electrical signal to calculate particle concentration.

During the production calibration process, the sensor records the original laser light intensity parameters and fan speed. The calibration algorithm is applied to the sensor output to minimize sensor drift and improve accuracy over the sensor's lifetime. This self calibration occurs on each power-on cycle.

### VALUE TO CUSTOMERS

- Detects particles ranging from  $0.3 \mu\text{m}$  to  $10 \mu\text{m}$
- Enables enhanced accuracy and cost-competitive monitoring or control of environmental particulate
- Enhanced response time of  $<6$  seconds and data update time of 1 second allows the IPM Series to respond to environmental conditions in near real time
- Robust metal design allows for use in harsh environments

### DIFFERENTIATION

- Highly accurate particle measurement of ( $\pm 10 \mu\text{g}/\text{m}^3$ ) with calibrated sensor outputs
- Low current consumption of 50 mA (typical) and option to provide ( $\sim 1.5 \mu\text{A}$ ) ensuring suitability for battery-powered applications
- Intelligent Self Calibration through a built-in algorithm to compensate for sensor drift over lifetime
- Super sleek and robust design achieved through metal housing
- Flexibility in outputs – two digital: I<sup>2</sup>C and UART, and one analog: PWM

### APPLICATIONS

- Air quality monitors (indoors and outdoors)
- Air purifiers (commercial and residential)
- Automotive cabin air purifiers
- HVAC (commercial and residential)



### FEATURES

- Laser-based (class 1) particle light scattering particle sensing
- Concentration range:  $0 \mu\text{g}/\text{m}^3$  to  $1,000 \mu\text{g}/\text{m}^3$
- Long life of up to 8 years with continuous operation
- Factory calibrated
- RoHS & REACH compliant

### PORTFOLIO

The Honeywell IPM Series joins the HPM Series, also engineered with light-scattering technology, to broaden the particulate sensor offering. To view the entire product portfolio, [click here](#).

**Honeywell**

# INTELLIGENT PARTICULATE MATTER SENSOR

## IPM SERIES

**TABLE 1. SPECIFICATIONS**

IH-PMC-001- air-in-out-same-side



IH-PMC-002 - air-in-out-opposite-sides



Characteristic	Minimum	Typical	Maximum	Unit
<b>Size</b>	49 mm × 31,5 mm × 10,8 mm [1.92 in × 1.24 in × 0.43 in]		44,8 mm × 31,8 mm × 10,8 mm [1.76 in × 1.25 in × 0.43 in]	
<b>Supply voltage</b>	4.75	5	5.25	V
<b>Operating current</b>	–	50	100	mA
<b>Standby current</b>	–	2.6	–	mA
<b>Sleep current<sup>3</sup></b>	–	150	–	µA
<b>Particle size</b>	0.3	2.5	10	µm
<b>Particle concentration</b>	0	–	1000	µg/m <sup>3</sup>
<b>Accuracy of PM2.5<sup>1</sup></b>	±10 µg/m <sup>3</sup> 0 µg/m <sup>3</sup> to 100 µg/m <sup>3</sup> ±10 % M.V. (100 µg/m <sup>3</sup> to 1000 µg/m <sup>3</sup> )			
<b>Accuracy of PM1, PM4, PM10<sup>1</sup></b>	±15 µg/m <sup>3</sup> 0 µg/m <sup>3</sup> to 100 µg/m <sup>3</sup> ±15 % M.V. (100 µg/m <sup>3</sup> to 1000 µg/m <sup>3</sup> )			–
<b>Data update period</b>	1			second
<b>Lifetime<sup>2</sup></b>	> 8 years			years
<b>Operating temperature</b>	-20	25	60	°C
<b>Storage temperature</b>	-30	25	70	°C

1. Test condition: Temperature of 25°C ±2°C; humidity of 50 %RH±10 %RH; reference instrument is TSI8530; source of particulate matter is cigarette smoke

2. Depending on the operating environment

3. Sleep mode can be enabled for sensor based on customer request

# INTELLIGENT PARTICULATE MATTER SENSOR IPM SERIES

## 2. OPERATING MODE

### OPTION 1

Figure 1. Operating Mode – Option 1

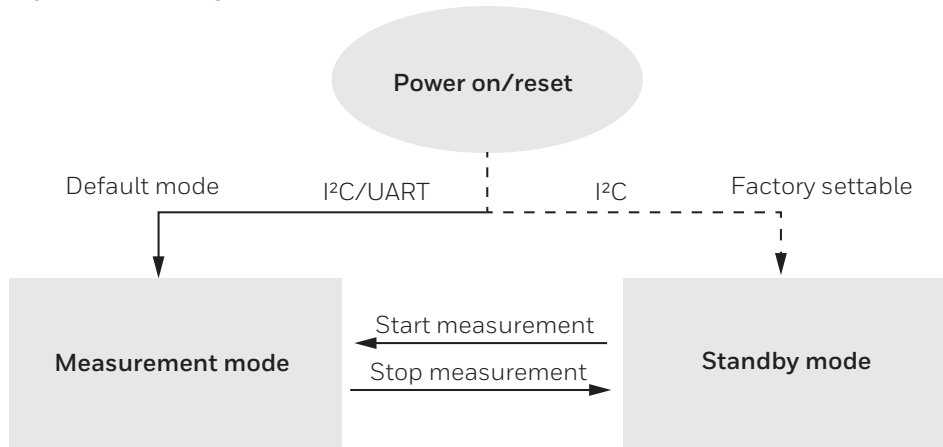

#### Measurement mode (Default Mode after power on)

- All electronics switched on/max. power consumption
- The measurement is running, and the module is continuously processing measurement data

#### Standby mode (c default mode)

- Fan and laser are switched off
- Most of the internal electronics switched off
- Microcontroller is in standby mode
- In standby mode, the UART/I<sup>2</sup>C interface is disabled and must first be activated by sending a low pulse on the RX/SDA line. This can be achieved by sending a byte such as "0xFF". After 10 ms of bus activation, user should send the "start measurement" command within 100 ms to put the sensor into measurement mode; If the "start measurement" command is not received within 100 ms, the sensor re-enters the standby mode.

# INTELLIGENT PARTICULATE MATTER SENSOR IPM SERIES

## OPTION 2

Figure 2. Operating Mode – Option 2

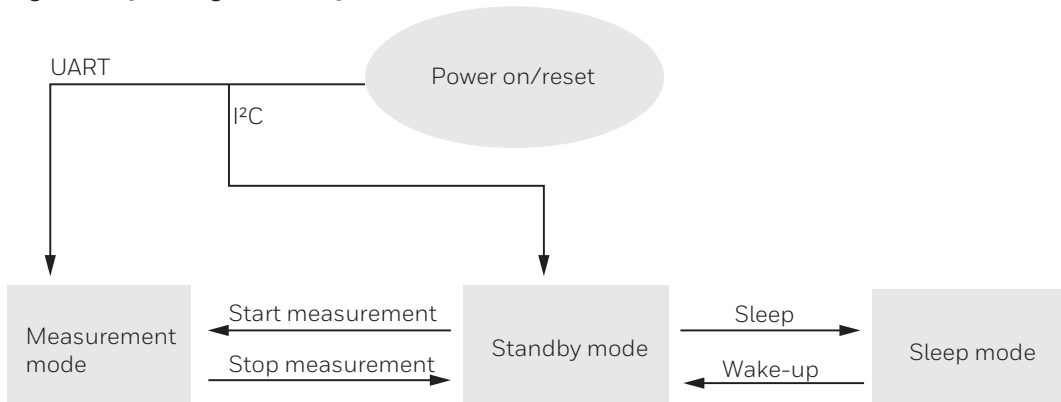

- For UART communication, the default mode is measurement mode
- In sleep mode, microcontroller is completely powered off (typical sleep current consumption 150 uA)
- A wakeup command needed to switch from sleep mode to standby mode
- To switch from standby mode to measurement mode, UART/I2C needs to be activated by sending a low pulse on the RX/SDA line. This can be achieved by sending a byte such as "0xFF"
- After 10 ms of bus activation, user should send the "start measurement" command within 100 ms to put the sensor into measurement mode
- If the "start measurement" command is not received within 100 ms, the sensor re-enters the standby mode

## 3. INTERFACE AND COMMUNICATION PROTOCOL

### 3.1 Pin assignment

Figure 3. PM 2.5 pinout and connector details

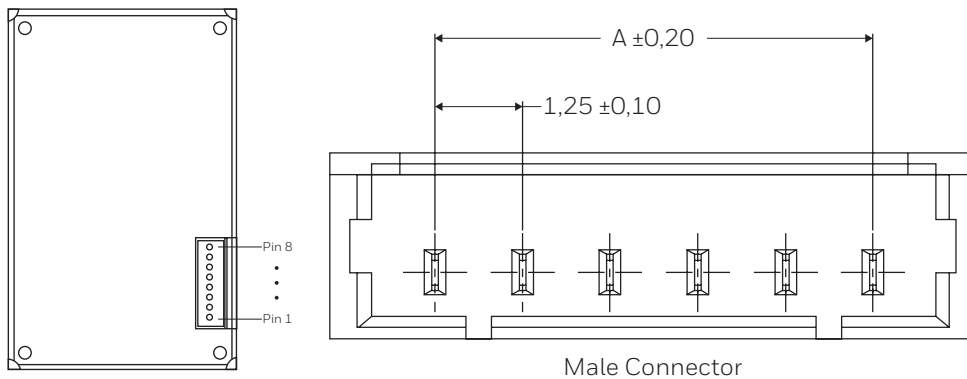

TABLE 2. PIN DEFINITION

Pin	Name	Function
Pin 1	VCC	Power
Pin 2	GND	Ground
Pin 3	SET	0: I <sup>2</sup> C; 1 or float: UART
Pin 4	RX/SDA	UART RX/ I <sup>2</sup> C SDA
Pin 5	TX/SCL	UART TX/ I <sup>2</sup> C SCL
Pin 6	NC	–
Pin 7	NC	–
Pin 8	PWM	PWM output

# INTELLIGENT PARTICULATE MATTER SENSOR IPM SERIES

Figure 4. IPM Series PM sensor wiring diagram (Unit: mm, terminal model: MX1.25-8Y)

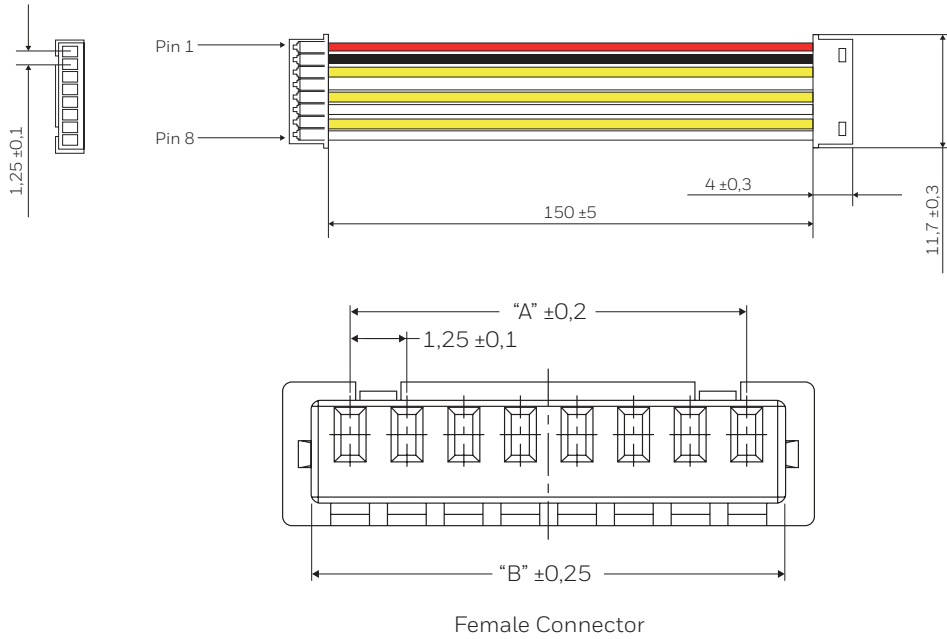

TABLE 3. PART NUMBERS

Item	Part Number	Pitch
Air-in-out-same-side	IH-PMC-001	1.25 ± 0.10
Air-in-out-opposite-sides	IH-PMC-002	1.25 ± 0.10

## 3.2 Communication interface

Honeywell Intelligent Particulate Matter Sensor supports standard I<sup>2</sup>C communication protocol and contains two pins, SDA and SCL, both pins need to be connected with external 2k to 10k pull-up resistors to VCC. The I<sup>2</sup>C communication address of the PM is 0x08 (7-bit), the write command is 0x10, and the read command is 0x11.

## 3.3 I<sup>2</sup>C communication protocol

### 3.3.1 Start measurement: 10 00 10 05 00 F6

Sending this command will enter the measurement mode



In the following commands, the meaning of the signals are the same.

### 3.3.2 Stop measurement: 10 01 04

Sending this command will exit the measurement mode.

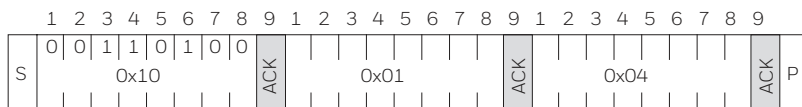

# INTELLIGENT PARTICULATE MATTER SENSOR IPM SERIES

## 3.3.3 Read the data: 10 03 00 11 Data0\_H Data0\_L Data0\_CRC.....

Send this command to read the measured value.

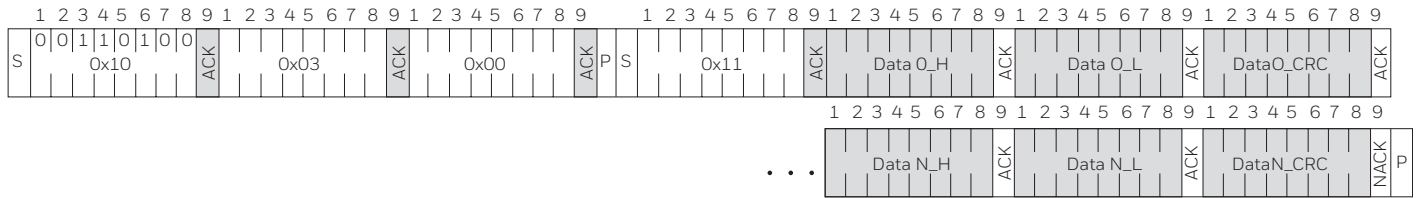

To read 30 bytes of valid data, the data description is shown in Table 4.

TABLE 4. DATA DESCRIPTION		
Byte	Data Type	Description
0~2	Each particulate measurement data is 16 bits with the sequence of high byte, low byte and a CRC check value	PM1.0 concentration=byte0*256+byte1 (unit: $\mu\text{g}/\text{m}^3$ ); Byte2 is the CRC checksum of byte0 and byte1;
3~5		PM2.5 concentration=byte3*256+byte4 (unit: $\mu\text{g}/\text{m}^3$ ); Byte5 is the CRC checksum of byte3 and byte4;
6~8		PM4.0 concentration=byte6*256+byte7 (unit: $\mu\text{g}/\text{m}^3$ ); Byte8 is the CRC checksum of byte6 and byte7;
9~11		PM10 concentration=byte9*256+byte10 (unit: $\mu\text{g}/\text{m}^3$ ); Byte11 is the CRC checksum of byte9 and byte10
12~14		Reserved
15~17		Reserved
18~20		Reserved
21~23		Reserved
24~26		Reserved
27~29		Reserved

The IPM Series sensor adopts CRC8 calculation with an initial value of 0xFF and polynomial of 0x31 ( $x^8+x^5+x^4+1$ ) to check data integrity. The code is as follows

```

//*****
// Function name: Calc_CRC8
// Function: CRC8 calculation, initial value: 0xFF, polynomial:
// 0x31 ( $x^8 + x^5 + x^4 + 1$ )
// Parameter: u8*dat: needs to verify the first address of the
// data; u8 Num: CRC verifies the data length
// Return: Check value calculated by crc:
//*****
unsigned char Calc_CRC8(unsigned char *data, unsigned char Num)
{
    unsigned char bit, byte, crc=0xFF;
    for(byte=0; byte<Num; byte++)
    {
        crc^=(data[byte]);
        for(bit=8; bit>0; --bit)
        {
            if(crc&0x80)
                crc=(crc<<1)^0x31;
            else
                crc=(crc<<1);
        }
    }
    return crc;
}

```

# INTELLIGENT PARTICULATE MATTER SENSOR

## IPM SERIES

### 3.4 UART communication protocol

#### 3.4.1 Serial port parameter

**TABLE 5. SERIAL PORT PARAMETER**

Data Domain	Parameter
Baud rate	1200
Data bit	8 bits
Stop bit	1 bit
Parity	None

#### 3.4.2 Communication protocol format

**TABLE 6. SERIAL PROTOCOL FORMAT**

Frame Head	Fixed Code	Length (1-byte)	Command (1-byte)	Data (n-bytes)	Check
FE	A5	XX	XX	XX	CS

**TABLE 7. SERIAL PROTOCOL FORMAT**

Protocol Domain	Detailed Description
Frame head	Value fixed to FE
Fixed code	Sensor category, value fixed to A5
Length	Length of data
Command code	Operation instruction code
Data	Data to be read or written
Check sum	Checksum (low byte) = fixed code + length + command code + data

#### 3.4.3 Serial Port Command

**TABLE 8. SERIAL PORT PROTOCOL COMMAND CODE**

Function Name	Detailed Description
Read the PM2.5 measurement	0x00
Read the PM1.0, PM2.5, PM10 measurement	0x01
Read the PM1.0, PM2.5, PM4.0, PM10 measurement	0x07
Stop measurement	0x10
Start measurement	0x11

#### a) Read the PM2.5 measurement result

**TABLE 9. READ THE PM2.5 MEASUREMENT RESULT**

Send	FE A5 00 00 A5
Response	FE A5 02 00 DF1 DF2 [CS]
Description	PM2.5 meas. value = DF1×256 + DF2 (unit: µg/m³)

# INTELLIGENT PARTICULATE MATTER SENSOR

## IPM SERIES

b) Read the PM1.0, PM2.5, PM10 measurement result

TABLE 10. READ THE PM1.0, P M2.5 AND PM10 MEASUREMENT RESULT	
<b>Send</b>	<b>FE A5 00 01 A6</b>
<b>Response</b>	FE A5 02 00 DF11 DF12 DF21 DF22 DF31 DF32 [CS]
<b>Description</b>	PM1.0 Meas. Value = DF11×256 + DF12 (Unit: µg/m <sup>3</sup> ) PM2.5 Meas. Value = DF21×256 + DF22 (Unit: µg/m <sup>3</sup> ) PM10 Meas. Value = DF31×256 + DF32 (Unit: µg/m <sup>3</sup> )

c) Read the PM1.0, PM2.5, PM4.0, PM10 measurement result

TABLE 11. READ THE PM1.0, PM2.5, PM4.0 AND PM10 MEASUREMENT RESULT	
<b>Send</b>	<b>FE A5 00 07 A6</b>
<b>Response</b>	FE A5 02 00 DF11 DF12 DF21 DF22 DF31 DF32 DF41 DF42 [CS]
<b>Description</b>	PM1.0 Meas. Value = DF11×256 + DF12 (Unit: µg/m <sup>3</sup> ) PM2.5 Meas. Value = DF21×256 + DF22 (Unit: µg/m <sup>3</sup> ) PM4.0 Meas. Value = DF31×256 + DF32 (Unit: µg/m <sup>3</sup> ) PM10 Meas. Value = DF41×256 + DF42 (Unit: µg/m <sup>3</sup> )

d) Stop measurement

TABLE 12. STOP MEASUREMENT	
<b>Send</b>	<b>FE A5 00 10 B5</b>
<b>Response</b>	FE A5 02 00 00 10 [CS]
<b>Description</b>	Stop measurement, enter the standby mode

e) Start measurement

TABLE 13. START MEASUREMENT	
<b>Send</b>	<b>FE A5 00 11 B6</b>
<b>Response</b>	FE A5 02 00 00 11 [CS]
<b>Description</b>	Start measurement, enter the measurement mode

### 3.5 PWM output

TABLE 14. PWM OUTPUT	
<b>PM2.5 concentration output range</b>	0 µg/m <sup>3</sup> to 1000 µg/m <sup>3</sup>
<b>Cycle</b>	1000 ms ±5 %
<b>High-level output at the cycle start section</b>	200 µs (Theoretical value)
<b>Mid-cycle</b>	1000 ms ±5 %
<b>End of the cycle section of the low-level transmission</b>	200 µs (Theoretical value)

Notes:

1. PM2.5 concentration values obtained by PWM output:  $P = 1000 \times (TH) / (TH + TL)$ ; P is the calculated PM2.5 concentration value in µg/m<sup>3</sup>; TH is the time of high levels in one output cycle. TL is the time of low levels in one output cycle
2. The values calculated by PWM represent only PM2.5
3. PWM output will not be available if default mode of operation is standby mode after power on



# INTELLIGENT PARTICULATE MATTER SENSOR IPM SERIES

Figure 5. PWM output timing diagram

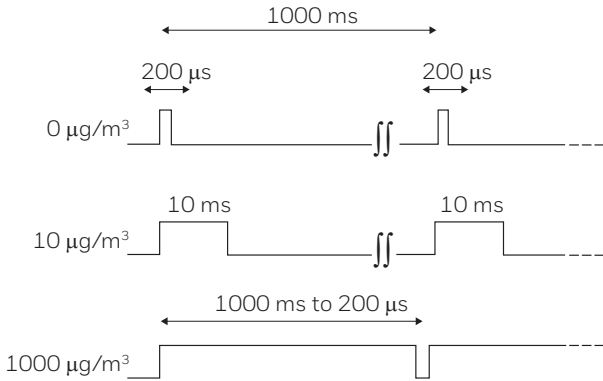

## 4. DIMENSIONS

Figure 6a. IH-PMC-001 (Air in-and-out on the same side)  
Unit: mm, tolerances: ISO2768-mK

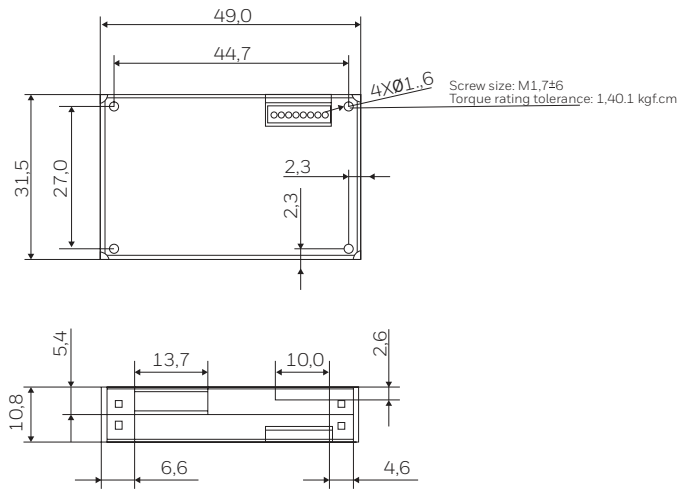
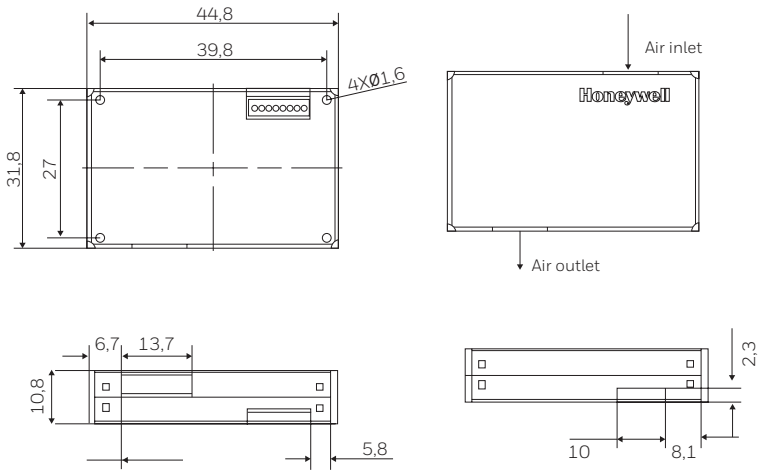

Figure 6b. IH-PMC-002 (Air in-and-out on opposite sides)



## 5. PACKAGING

IPM Series PM sensor is packed in a plastic tray with 25 sensors per tray as shown in Figure 7.

Figure 7. Size of plastic tray (unit: mm, tolerances: ISO2768-mK)

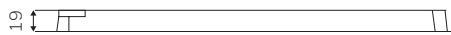
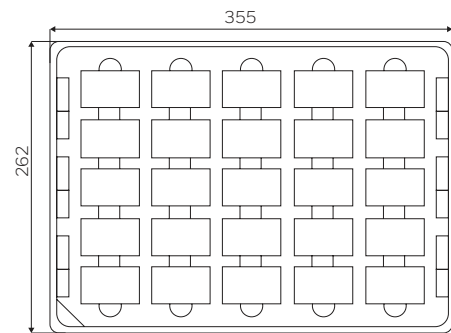

The weight of one sensor is about 22 g.

# INTELLIGENT PARTICULATE MATTER SENSOR IPM SERIES

## 6. PRECAUTIONS

- 6.1 Since the metal shell of the sensor is connected to the internal power supply, do not connect the sensor shell to external circuits or other instrument shell.
- 6.2 The side of sensor with air inlet and outlet should be closely attached to the vent on the inner wall of target instrument. No obstructions should be around the air outlet within 2 cm. There must be barrier between air inlet and outlet to prevent air returning directly from the air outlet to the inlet

**Figure 8. PM 2.5 Airflow**

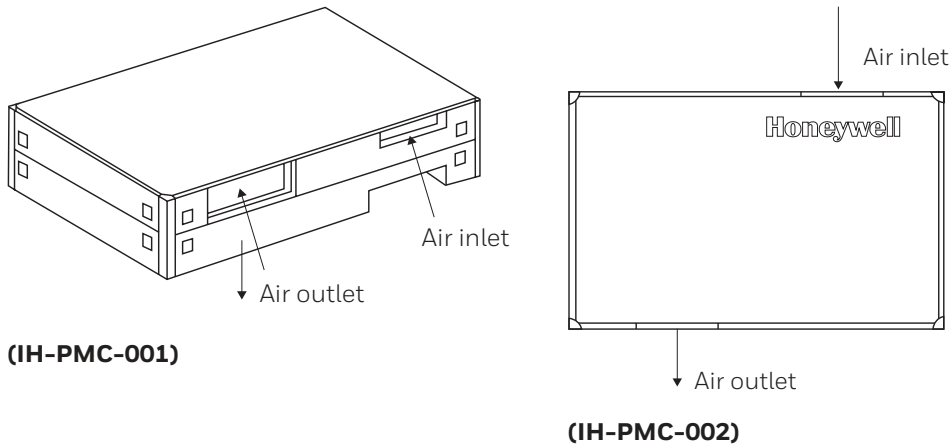

- 6.3 The size of air inlet and outlet in equipment should be larger than that of air inlet in sensor.
- 6.4 When used for purifier, do not install the sensor directly into the duct of purifier. An independent space should be designed to install the sensor to isolate the sensor from the purifier's duct.
- 6.5 Sensor should be installed at least 20 cm above the ground, otherwise there may be large particles such as dust, floating material or fluff causing failure of fan in sensor. Appropriate pre-filter is strongly recommended to be used.
- 6.6 Do not disassemble the sensor to prevent irreversible damage.
- 6.7 Sensors have been tested and their accuracies have been validated at the factory with test conditions include a temperature of  $25^{\circ}\text{C} \pm 2^{\circ}\text{C}$ ; humidity of  $50\% \text{RH} \pm 10\% \text{RH}$ ; reference instrument is TSI8530 and source of particulate matter is cigarette smoke.
- 6.8 This sensor is suitable for normal indoor environment, if use in the following environment, the sensor's data consistency may reduce due to excessive dust accumulation, oil accumulation or water entering:
  - a. Dust concentration greater than  $300 \mu\text{g}/\text{m}^3$  in six months one year, or dust concentration greater than  $500 \mu\text{g}/\text{m}^3$  in two months one year
  - b. Lampblack environment
  - c. High water fog environment
  - d. Outdoor

## WARRANTY/REMEDY

Honeywell warrants goods of its manufacture as being free of defective materials and faulty workmanship during the applicable warranty period. Honeywell's standard product warranty applies unless agreed to otherwise by Honeywell in writing; please refer to your order acknowledgment or consult your local sales office for specific warranty details. If warranted goods are returned to Honeywell during the period of coverage, Honeywell will repair or replace, at its option, without charge those items that Honeywell, in its sole discretion, finds defective.

**The foregoing is buyer's sole remedy and is in lieu of all other warranties, expressed or implied, including those of merchantability and fitness for a particular purpose. In no event shall Honeywell be liable for consequential, special, or indirect damages.**

While Honeywell may provide application assistance personally, through our literature and the Honeywell web site, it is buyer's sole responsibility to determine the suitability of the product in the application.

Specifications may change without notice. The information we supply is believed to be accurate and reliable as of this writing. However, Honeywell assumes no responsibility for its use.

### For more information

Honeywell Sensing & Safety Technologies services its customers through a worldwide network of sales offices and distributors. For application assistance, current specifications, pricing or the nearest Authorized Distributor, visit our [website](#) or call:

USA/Canada	+1 302 613 4491
Latin America	+1 305 805 8188
Europe	+44 1344 238258
Japan	+81 (0) 3-6730-7152
Singapore	+65 6355 2828
Greater China	+86 4006396841

### Honeywell Sensing & Safety Technologies

830 East Arapaho Road  
Richardson, TX 75081  
[www.honeywell.com](http://www.honeywell.com)

## WARNING PERSONAL INJURY

DO NOT USE these products as safety or emergency stop devices or in any other application where failure of the product could result in personal injury.

**Failure to comply with these instructions could result in death or serious injury.**

## WARNING MISUSE OF DOCUMENTATION

- The information presented in this product sheet is for reference only. Do not use this document as a product installation guide.
- Complete installation, operation, and maintenance information is provided in the instructions supplied with each product.

**Failure to comply with these instructions could result in death or serious injury.**