

## **Wavelength-Selectable High-Power D2547P-Type CW DFB Laser Module**

---

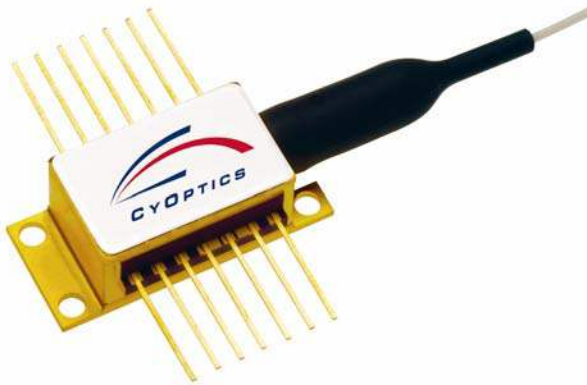

Featuring wavelength selection to the DWDM ITU-T grid, the D2547P Laser Modules are ideally suited for use with external lithium niobate modulators, and in high-power (20 mW) applications.

### **Features**

- High-performance, multiquantum-well (MQW), distributed-feedback (DFB) laser
- D2547P-Type is offered on 100 GHz ITU grid wavelengths ranging from 1528.77 nm—1610.06 nm
- Polarization-maintaining fiber pigtail
- For use with lithium niobate modulators
- High optical power (20 mW, CW)
- Hermetic, 14-pin package

### **Applications**

- Telecommunications:
  - Dense WDM
  - SONET/SDH OC-192/ STM-64
  - Extended and ultra-long reach
  - Undersea systems
- Digital video

### **Description**

The D2547P-Type DFB laser module is designed for use with an external lithium niobate modulator and also in applications where high power (20 mW) is required.

The laser comes packaged in an industry-standard 14-pin butterfly module with a polarization-maintaining fiber pigtail.

Temperature-stabilized with a thermoelectric cooler (TEC) and thermistor, the package is available in C and L band ITU-T grid wavelengths on a 100 GHz spacing plan.

D2547P does not contain a wavelength locker, which is not needed for high-reliability operation in 100GHz-spaced applications. For a 20 mW CW laser butterfly version with integrated wavelength locker and available on a 50 GHz grid, refer to the companion product data sheet for D3587P.

**Description** (continued)

**Controlled Feedback**

The module contains an internal optical isolator that suppresses optical feedback in laser-based, fiber-optic systems. Light reflected back to the laser is attenuated a minimum of 30 dB.

**Controlled Temperature**

An integral TEC provides stable thermal characteristics. The TEC allows for heating and cooling of the laser chip to maintain a temperature constant as the case temperature changes from  $-5\text{ }^{\circ}\text{C}$  to  $+75\text{ }^{\circ}\text{C}$ . The laser temperature is monitored by the internal thermistor, which can be used with external circuitry to control the laser chip temperature.

**Controlled Power**

An InGaAs PIN photodiode functions as the back-facet power monitor. The photodiode monitors emission from the rear facet of the laser and, when used in conjunction with control circuitry, can control optical power launched into the fiber. Normally, this configuration is used in a feedback arrangement to maintain consistent laser output power.

**Standard Package**

The laser module is fabricated in a 14-pin, hermetic, metal/ceramic butterfly package.

The laser module is equipped with *Fujikura*<sup>®</sup> polarization-maintaining fiber (PMF). The fiber is PANDA type it has a mode field diameter of  $10.5\text{ }\mu\text{m}$ , a cladding diameter of  $125\text{ }\mu\text{m} \pm 3\text{ }\mu\text{m}$ , and a tight-buffered coating, all within a  $900\text{ }\mu\text{m}$  diameter, loose tube jacket. Figure 1 shows the orientation of polarization in the fiber without the loose tubing.

CyOptics' optoelectronic components are qualified to rigorous internal standards that are consistent with *Telcordia Technologies*<sup>™</sup> TR-NWT-000468. All design and manufacturing operations are *ISO*<sup>®</sup> 9001 certified.

**Pin Information**

**Table 1. Pin Descriptions**

Pin	D2547P-Type
1	Thermistor
2	Thermistor
3	Laser dc Bias (Cathode) (-)
4	Back-facet Monitor Anode (-)
5	Back-facet Monitor Cathode (+)
6	TEC (+) <sup>1</sup>
7	TEC (-) <sup>1</sup>
8	Case Ground
9	Case Ground
10	Case Ground
11	Laser Anode (+)
12	Laser Input Cathode (-)
13	Laser Anode (+)
14	Case Ground

1. A positive current through the thermoelectric heat pump cools the laser.

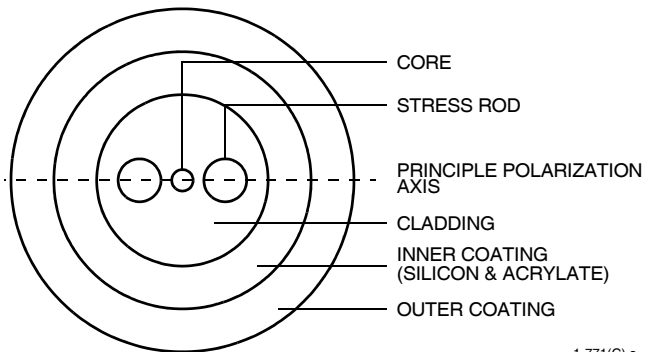

1-771(C).a

**Figure 1. Polarization-Maintaining Fiber without Jacket**

## Functional Description

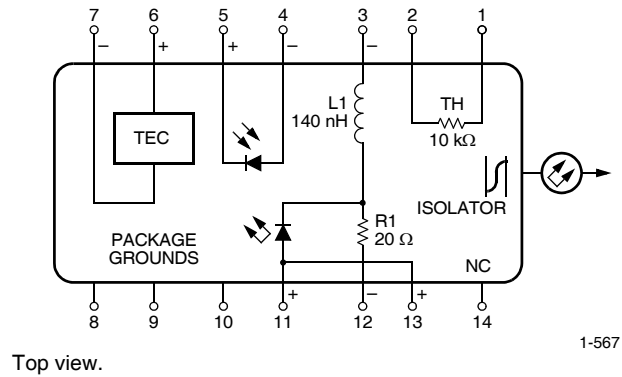

Figure 2. D2547P Circuit Schematic

## Absolute Maximum Ratings

Stresses in excess of the absolute maximum ratings can cause permanent damage to the device. These are absolute stress ratings only. Functional operation of the device is not implied at these or any other conditions in excess of those given in the operations sections of the data sheet. Exposure to absolute maximum ratings for extended periods can adversely affect device reliability.

Parameter	Symbol	Min	Max	Unit
Laser DC Reverse Voltage	VRLMAX	—	2	V
Laser DC Forward Current	IFLMAX	—	225	mA
Operating Case Temperature Range	T <sub>C</sub>	-5	75	°C
Storage Case Temperature Range <sup>1</sup>	T <sub>stg</sub>	-40	85 <sup>2</sup>	°C
Photodiode dc Reverse Voltage	VRPDMAX	—	10	V
Photodiode dc Forward Current	IFPDMAX	—	2	mA
Thermistor Temperature <sup>3</sup>	—	—	100	°C
Thermoelectric Cooler in Heating Mode <sup>3</sup>	ITEC	—	0.5	A

1. Does not apply to shipping container.

2. Maximum 2000 hrs. at extreme conditions.

3. To prevent package over-temperature conditions.

## Handling Precautions

### Power Sequencing

To avoid the possibility of damage to the laser module from power supply switching transients, follow this turn-on sequence:

1. All ground connections
2. Most negative supply
3. Most positive supply
4. All remaining connections

Reverse the order for the proper turn-off sequence.

## Electrostatic Discharge

**CAUTION: This device is susceptible to damage as a result of electrostatic discharge. Take proper precautions during both handling and testing. Follow guidelines such as JEDEC Publication No. 108-A (Dec. 1988).**

CyOptics employs a human-body model (HBM) for ESD-susceptibility testing and protection-design evaluation. ESD voltage thresholds are dependent on the critical parameters used to define the model. A standard HBM (resistance = 1.5 kΩ, capacitance = 100 pF) is widely used and, therefore, can be used for comparison purposes.

## Mounting Instructions

The minimum fiber bend radius is 1.0 in. (25.4 mm).

To avoid degradation in performance, mount the module on the board as follows:

1. Place the bottom flange of the module on a flat heat sink at least 0.5 in. x 1.180 in. (12.7 mm x 30 mm) in size. The surface finish of the heat sink should be better than 32 μin. (0.8 μm), and the surface flatness must be better than 0.001 in. (25.4 μm). Using thermal conductive grease is optional; however, thermal performance can be improved by up to 5% if conductive grease is applied between the bottom flange and the heat sink.
2. Mount four #2-56 screws with Fillister heads (M2-3 mm) at the four screw hole locations (see Outline Diagram). The Fillister head diameter must not exceed 0.140 in. (3.55 mm). Do not apply more than 1 in.-lb. of torque to the screws.

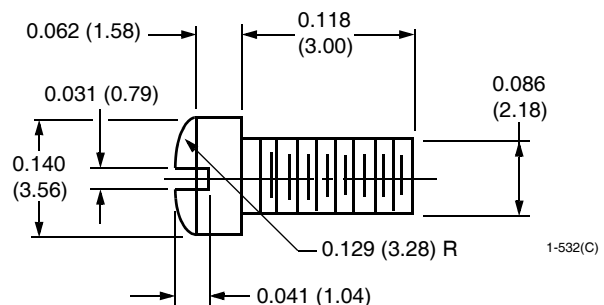

Note: Dimensions are in inches and (millimeters).

Figure 3. Fillister Head Screw

For additional information and latest specifications, see our website: [www.cyoptics.com](http://www.cyoptics.com)

## Characteristics

Minimum and maximum values are testing requirements. Typical values are device characteristics and are results of engineering evaluations; they are for information purposes only and are not part of the testing requirements. All parameters are beginning of life, unless otherwise specified.

**Table 2. D2547P-Type Electrical Characteristics**

Parameter	Symbol	Test Conditions	Min	Typ	Max	Unit
Threshold Current	$I_{TH}$	—	—	15	40	mA
Drive Current	—	$I_F = 20 \text{ mW}$	—	—	165	mA
Laser Forward Voltage	$V_{LF}$	$I_F = 20 \text{ mW (CW)}$	—	2	2.5	V
Monitor Reverse-bias Voltage <sup>1</sup>	$V_{RMON}$	—	3	5	10	V
Back-facet Monitor Current:	$I_{RMON}$	$P_O = 20 \text{ mW (CW)}$	0.2	—	3.0	mA
Monitor Dark Current	$I_D$	$I_F = 0, V_{RMON} = 5 \text{ V}$	—	0.01	0.1	$\mu\text{A}$
Input Impedance	$Z_{IN}$	—	—	25	—	$\Omega$
Thermistor Current	$I_{TC}$	—	10	—	100	$\mu\text{A}$
Resistance Ratio <sup>2</sup>	—	—	9.1	9.6	10.1	—
Thermistor Resistance	$R_{TH}$	$T_L = 25 \text{ }^\circ\text{C}$	9.5	—	10.5	k $\Omega$
Laser Submount Temperature	$T_{LASER}$	—	20	—	35	$^\circ\text{C}$
TEC Current	$I_{TEC}$	$T_C = 75 \text{ }^\circ\text{C}$	—	—	1.2	A
TEC Voltage	$V_{TEC}$	$T_C = 75 \text{ }^\circ\text{C}$	—	—	2.5	V
TEC Capacity	$\Delta T$	$T_C = 75 \text{ }^\circ\text{C}$	—	—	55	$^\circ\text{C}$

<sup>1</sup> Standard operating condition is 5.0 V reverse bias.

<sup>2</sup> Ratio of thermistor resistance at 0  $^\circ\text{C}$  to thermistor resistance at 50  $^\circ\text{C}$ .

**Table 3. D2547P-Type Optical Characteristics**

Parameter	Symbol	Test Conditions	Min	Typ	Max	Unit
Optical Output Power	$P_P$	—	20.0	—	—	mW
Center Wavelength* (See Ordering Information)	$\lambda_C$	$T_L = T_{SET}$ $\lambda_C = \lambda_{ITU} \pm 0.1 \text{ nm}$	1528.77	—	1610.06	nm
Line Width (3 dB full width)	$\Delta\lambda$	CW, $P_F = 20.0 \text{ mW}$	—	2	10	MHz
Side-mode Suppression Ratio	SMSR	CW	35	45	—	dB
Relative Intensity Noise	RIN	CW, $P_F = 20 \text{ mW}$ 200 MHz < f < 10 GHz	—	—	-135	dB/Hz
Optical Isolation	—	$T_C = 0 \text{ }^\circ\text{C}$ to 75 $^\circ\text{C}$	30	—	—	dB
Optical Polarization Extinction Ratio <sup>†</sup>	—	0 $^\circ\text{C}$ to 75 $^\circ\text{C}$	20	—	—	dB
FM Efficiency	FM	$P_F = 20 \text{ mW}$	—	100	—	MHz/mA
Wavelength Drift (EOL)	$\Delta\lambda_C$	Tested over 25-year lifetime	—	—	$\pm 0.1$	nm

\* Custom wavelengths available.

<sup>†</sup> The ST ferrule key is not aligned to slow axis of fiber. Connector is intended for testing purposes only.

Characteristics (continued)

Table 4. D2547P Fiber Pigtail and Optical Connector Characteristics

Parameter	Symbol	Description	Min	Typ	Max	Unit
Pigtail Length	L	Fujikura PANDA or equivalent polarization-maintaining fiber	1.5	—	—	m
Connector Style	—	ST plug (FC/PC optional)	—	—	—	—

Outline Diagram

Dimensions are in inches and (millimeters). Tolerances are  $\pm 0.005$  in. ( $\pm 0.127$  mm).

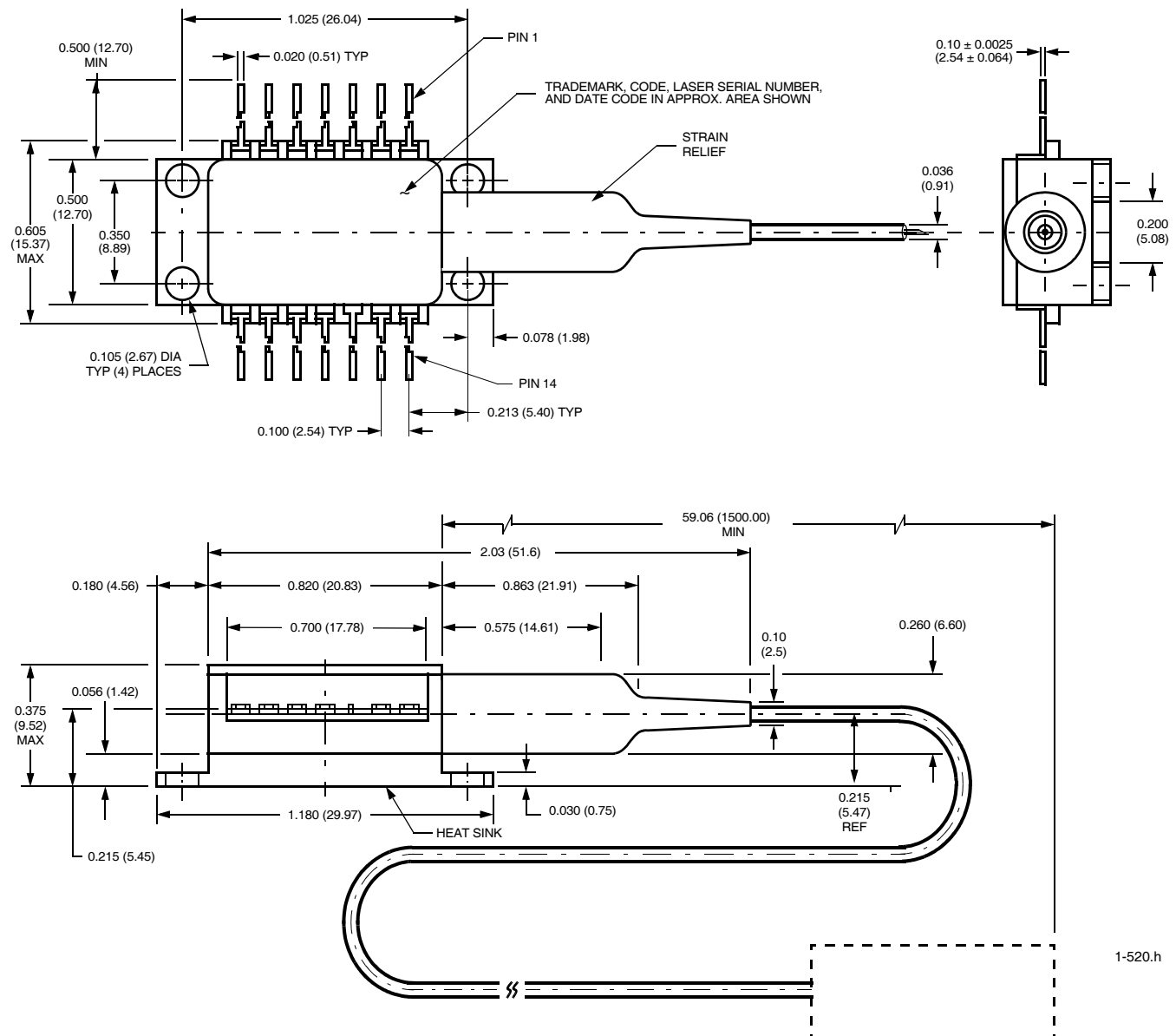

## High-Power Product

### Class IIIb Laser Product

FDA/CDRH Class IIIb laser product. All versions are Class IIIb laser products per CDRH, 21 CFR 1040 Laser Safety requirements. All versions are classified Class 3B laser products consistent with *IEC*<sup>®</sup> 60825-1: 1993. This device family has been classified with the FDA under accession number 8720010. Measurements were made to classify the product per *IEC* 60825-1: 1993.

This product complies with 21 CFR 1040.10 and 1040.11.

PANDA-type 10.5  $\mu\text{m}$ /125  $\mu\text{m}$   $\pm 3$   $\mu\text{m}$  single-mode fiber with a tight-buffered coating, all within a 900  $\mu\text{m}$  diameter, loose-tube jacket. Connector is included.

Wavelength = 1.5  $\mu\text{m}$

Maximum power = 40 mW

Because of size constraints, laser safety labeling (including an FDA Class IIIb label) is not affixed to the module but attached to the outside of the shipping carton.

Product is not shipped with power supply.

**Caution: Use of controls, adjustments, and procedures other than those specified herein may result in hazardous laser radiation exposure.**

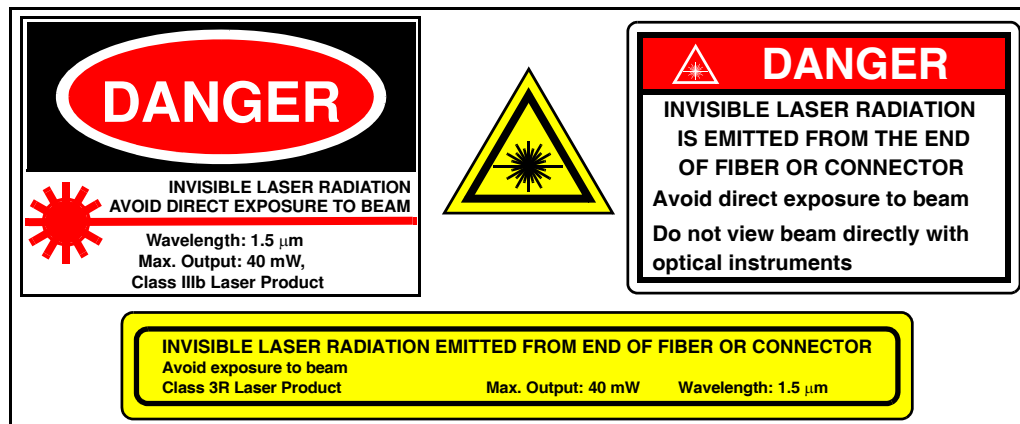

**Ordering Information** (continued)

**Table 5. D2547P 20 mW CW Laser Without Locker (C-Band) Ordering Information**

Device Code	ITU-T Frequency (THz)	Center Wavelength (nm)	Device Code	ITU-T Frequency (THz)	Center Wavelength (nm)
D2547P61	196.1	1528.77	D2547P38	193.8	1546.92
D2547P60	196.0	1529.55	D2547P37	193.7	1547.72
D2547P59	195.9	1530.33	D2547P36	193.6	1548.51
D2547P58	195.8	1531.12	D2547P35	193.5	1549.32
D2547P57	195.7	1531.90	D2547P34	193.4	1550.12
D2547P56	195.6	1532.68	D2547P33	193.3	1550.92
D2547P55	195.5	1533.47	D2547P32	193.2	1551.72
D2547P54	195.4	1534.25	D2547P31	193.1	1552.52
D2547P53	195.3	1535.04	D2547P30	193.0	1553.33
D2547P52	195.2	1535.82	D2547P29	192.9	1554.13
D2547P51	195.1	1536.61	D2547P28	192.8	1554.94
D2547P50	195.0	1537.40	D2547P27	192.7	1555.75
D2547P49	194.9	1538.19	D2547P26	192.6	1556.55
D2547P48	194.8	1538.98	D2547P25	192.5	1557.36
D2547P47	194.7	1539.77	D2547P24	192.4	1558.17
D2547P46	194.6	1540.56	D2547P23	192.3	1558.98
D2547P45	194.5	1541.35	D2547P22	192.2	1559.79
D2547P44	194.4	1542.14	D2547P21	192.1	1560.61
D2547P43	194.3	1542.94	D2547P20	192.0	1561.42
D2547P42	194.2	1543.73	D2547P19	191.9	1562.23
D2547P41	194.1	1544.53	D2547P18	191.8	1563.05
D2547P40	194.0	1545.32	D2547P17	191.7	1563.86
D2547P39	193.9	1546.12			



**Ordering Information** (continued)

**Table 6. D2547P 20 mW CW Laser Without Locker (L-Band) Ordering Information**

<b>Device Code</b>	<b>ITU Frequency (THz)</b>	<b>Center Wavelength (nm)</b>	<b>Device Code</b>	<b>ITU Frequency (THz)</b>	<b>Center Wavelength (nm)</b>
D2547P916	191.6	1564.68	D2547P888	188.8	1587.88
D2547P915	191.5	1565.50	D2547P887	188.7	1588.73
D2547P914	191.4	1566.31	D2547P886	188.6	1589.57
D2547P913	191.3	1567.13	D2547P885	188.5	1590.41
D2547P912	191.2	1567.95	D2547P884	188.4	1591.26
D2547P911	191.1	1568.77	D2547P883	188.3	1592.10
D2547P910	191.0	1569.59	D2547P882	188.2	1592.95
D2547P909	190.9	1570.42	D2547P881	188.1	1593.79
D2547P908	190.8	1571.24	D2547P880	188.0	1594.64
D2547P907	190.7	1572.06	D2547P879	187.9	1595.49
D2547P906	190.6	1572.89	D2547P878	187.8	1596.34
D2547P905	190.5	1573.71	D2547P877	187.7	1597.19
D2547P904	190.4	1574.54	D2547P876	187.6	1598.04
D2547P903	190.3	1575.37	D2547P875	187.5	1598.89
D2547P902	190.2	1576.20	D2547P874	187.4	1599.75
D2547P901	190.1	1577.03	D2547P873	187.3	1600.60
D2547P900	190.0	1577.86	D2547P872	187.2	1601.46
D2547P899	189.9	1578.69	D2547P871	187.1	1602.31
D2547P898	189.8	1579.52	D2547P870	187.0	1603.17
D2547P897	189.7	1580.35	D2547P869	186.9	1604.03
D2547P896	189.6	1581.18	D2547P868	186.8	1604.88
D2547P895	189.5	1582.02	D2547P867	186.7	1605.74
D2547P894	189.4	1582.85	D2547P866	186.6	1606.60
D2547P893	189.3	1583.69	D2547P865	186.5	1607.47
D2547P892	189.2	1584.53	D2547P864	186.4	1608.33
D2547P891	189.1	1585.36	D2547P863	186.3	1609.19
D2547P890	189.0	1586.20	D2547P862	186.2	1610.06

*Fujikura* is a registered trademark of Fujikura Ltd.  
*Telcordia Technologies* is a trademark of Telcordia Technologies, Inc.  
*ISO* is a registered trademark of The International Organization for Standardization.

---

For additional information, contact your CyOptics Account Manager or the following:

INTERNET: <http://www.cyoptics.com>  
Telephone: 484-397-3800  
Fax: 484-397-3592  
Email: <mailto:sales@cyoptics.com>  
Info Email: <mailto:sales@cyoptics.com>

---

*The information enclosed (including but not limited to technical specifications, recommendations, and application notes) relating to the products herein is believed to be reliable and accurate and is subject to change without notice. No risk and liability is assumed for use of the products and its applications. CyOptics, Inc. reserves the right to change without notice design, specification, form, fit or function relating to the products herein.*

Copyright © 2005 CyOptics, Inc.  
All Rights Reserved

March 2006  
DS06-040 (Replaces DS05-040)

