

REVISIONS					
P	LTR	DESCRIPTION	DATE	DMN	APVD
J		REVISED PER ECO-17-018523	19JAN2018	PHM	CT

"04"	MODULE A: SZ 22 POSTED PIN CONTACT: TE P/N 211431-6 (QTY=60) MODULE B: SZ 22 POSTED PIN CONTACT: TE P/N 211431-6 (QTY=60) MODULE C: SZ 16 POSTED PIN CONTACT: TE P/N 1663128-8 (QTY=2) LOADED IN POSITION #2 & 4 SZ 12 SEALING PLUG: TE P/N 1663605-1 (QTY=1) LOADED IN POSITION #3 SZ 5 SEALING PLUG: TE P/N 205975-1 (QTY=1) LOADED IN POSITION #5	1663302-3
"01"	MODULE A: SZ 22 POSTED PIN CONTACT: TE P/N 211431-6 (QTY=60) MODULE B: SZ 22 POSTED PIN CONTACT: TE P/N 211431-6 (QTY=60) MODULE C: SZ 16 POSTED PIN CONTACT: TE P/N 1663128-8 (QTY=2) LOADED IN POSITION #2 & 4 SZ 12 SEALING PLUG: TE P/N 1663605-1 (QTY=1) LOADED IN POSITION #3 SZ 5 SEALING PLUG: TE P/N 205975-1 (QTY=1) LOADED IN POSITION #5	1663302-2
"01"	MODULE A: SZ 22 POSTED PIN CONTACT: TE P/N 211431-6 (QTY=60) MODULE B: SZ 22 POSTED PIN CONTACT: TE P/N 211431-6 (QTY=60) MODULE C: SZ 16 POSTED PIN CONTACT: TE P/N 1663128-8 (QTY=2) LOADED IN POSITION #2 & 4 SZ 12 SEALING PLUG: TE P/N 1663605-1 (QTY=1) LOADED IN POSITION #3 SZ 5 SEALING PLUG: TE P/N 205975-1 (QTY=1) LOADED IN POSITION #5	1663302-1
KEYING POSITION	CONTACTS & SEALING PLUGS INCLUDED AND INSTALLED	PART NUMBER

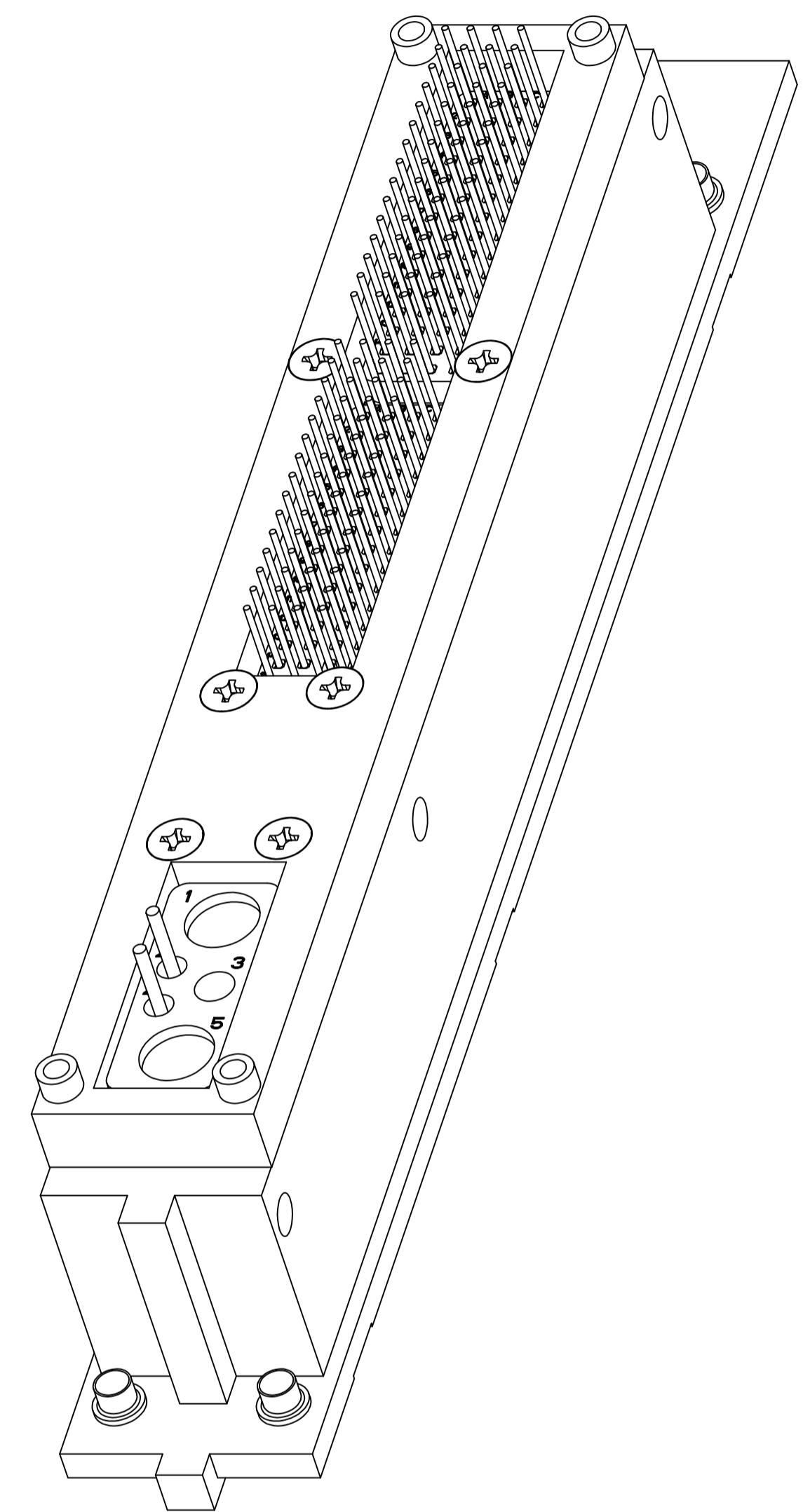
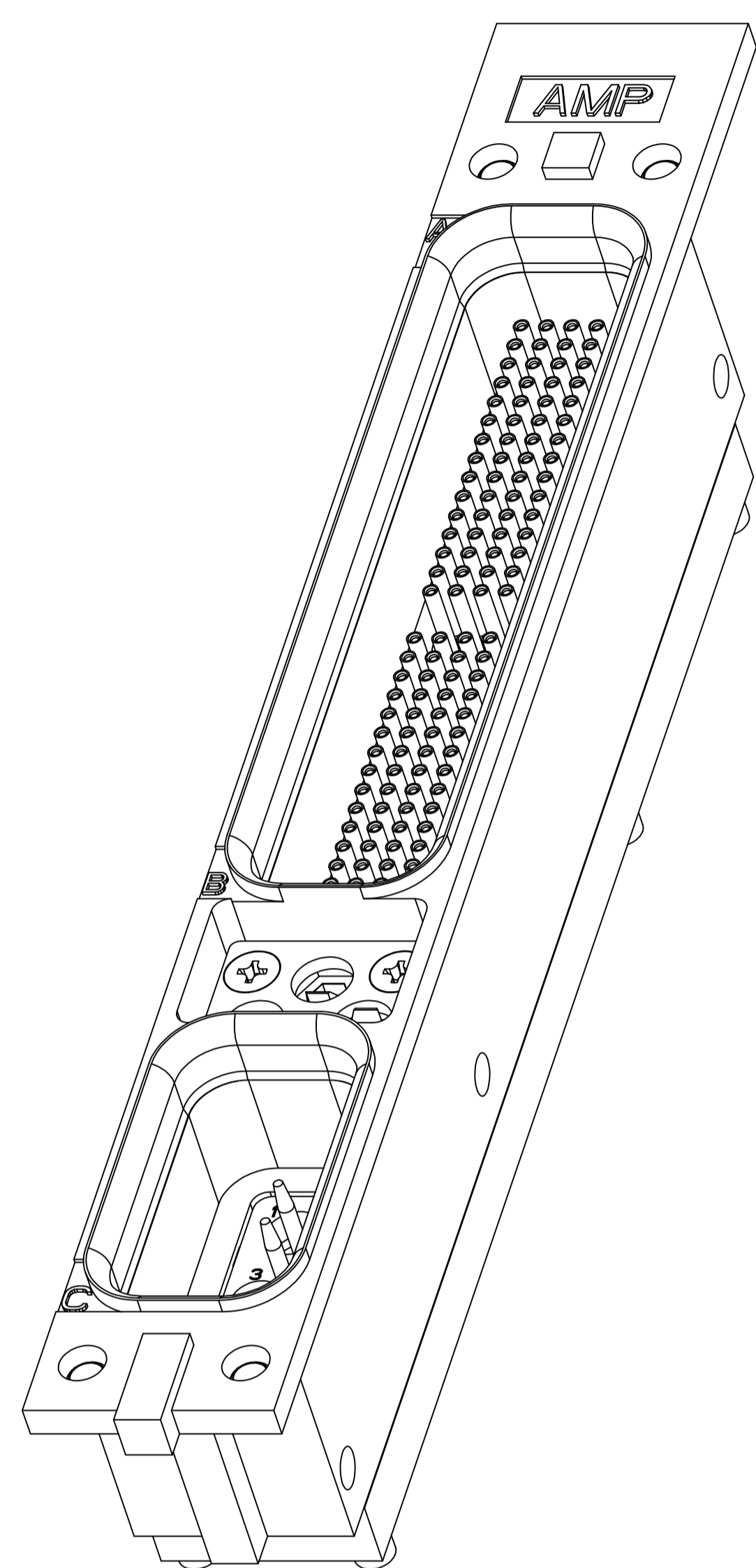

COMPONENT	MATERIAL	FINISH
SHELL	SEE TABLE	SEE TABLE
HOUSING RETENTION PLATE	SEE TABLE	SEE TABLE
FLAT HEAD SCREWS	STAINLESS STEEL	PASSIVATED
POLARIZING KEYS	ZINC ALLOY PER ASTM-B-86	-
POLARIZING KEY RETAINING PLATE	ALUMINUM ALLOY PER ASTM-B-209	BLUE ANODIZED PER MIL-A-8625
60 & 5C2 INSERTS	THERMOSET	-
FILLER PLUG	TEFLON	-

- PARTS MEET THE REQUIREMENTS OF THE ARINC 600 SPECIFICATION.
- EPOXY MATERIAL MAY FORM A .040 [1.01] BEAD BEYOND THIS DIMENSION.
- SHELL & RETENTION PLATE MATERIAL: ALUMINUM ALLOY A380 PER QQ-A-591 FINISH: CHROMATE CONVERSION PER MIL-C-5541, TYPE II, CLASS 3
- SHELL & RETENTION PLATE MATERIAL: ALUMINUM ALLOY A380 PER QQ-A-591 FINISH: ELECTROLESS NICKEL PER MIL-C-26074.
- KEYING SHOWN IN POSITION FOR REFERENCE ONLY. SEE TABLE FOR KEYING POSITION. FOR POSITION "00" KEYING SHIPPED UNASSEMBLED.

3	"04"	1663302-3
4	"01"	1663302-2
3	"01"	1663302-1
SHELL MAT'L & FINISH	KEYING POSITION	PART NO.

THIS DRAWING IS A CONTROLLED DOCUMENT.		DWG: C.C.THOMAS 1-28-03	TE Connectivity Ltd.	
DIMENSIONS: INCHES [mm]		CHK: LARRY OH 1-28-03	NAME: RECEPTACLE ASSEMBLY, SIZE ONE ARINC 600, FRONT RELEASE FILTERED SPECIAL	
TOLERANCES UNLESS OTHERWISE SPECIFIED:		APVD: LARRY OH 1-28-03	SIZE: A1	
0. PLC ± -		PRODUCT SPEC: -	CAGE CODE: 00779	
1. PLC ± -		APPLICATION SPEC: -	DRAWING NO: 1663302	
2. PLC ± -		RESTRICTED TO: -	SCALE: 2:1	
3. PLC ± .005 [0.13]		WEIGHT: -	SHEET 1 OF 2	
4. PLC ± -		CUSTOMER DRAWING	REV J	
ANGLES ± -				

REVISIONS				
P	LTR	DESCRIPTION	DATE	APPV
-	SEE SHEET 1			

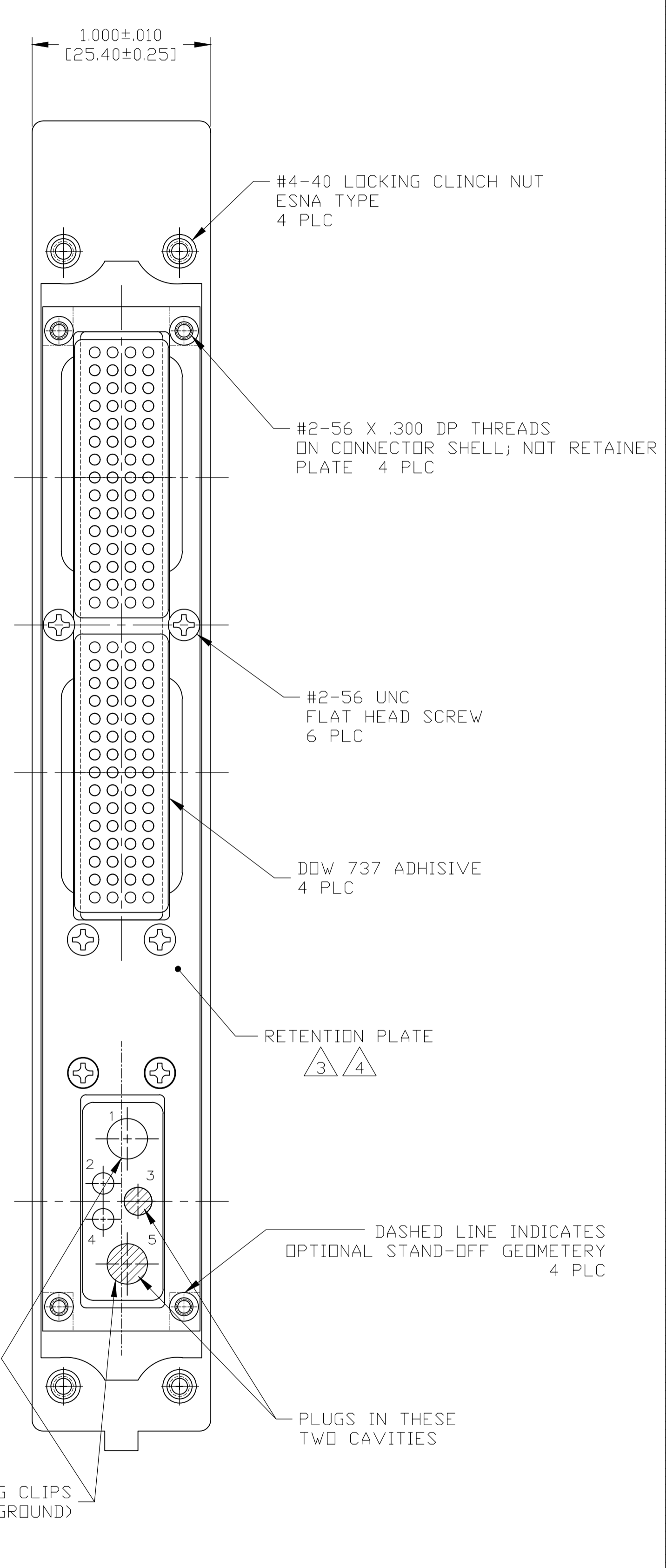
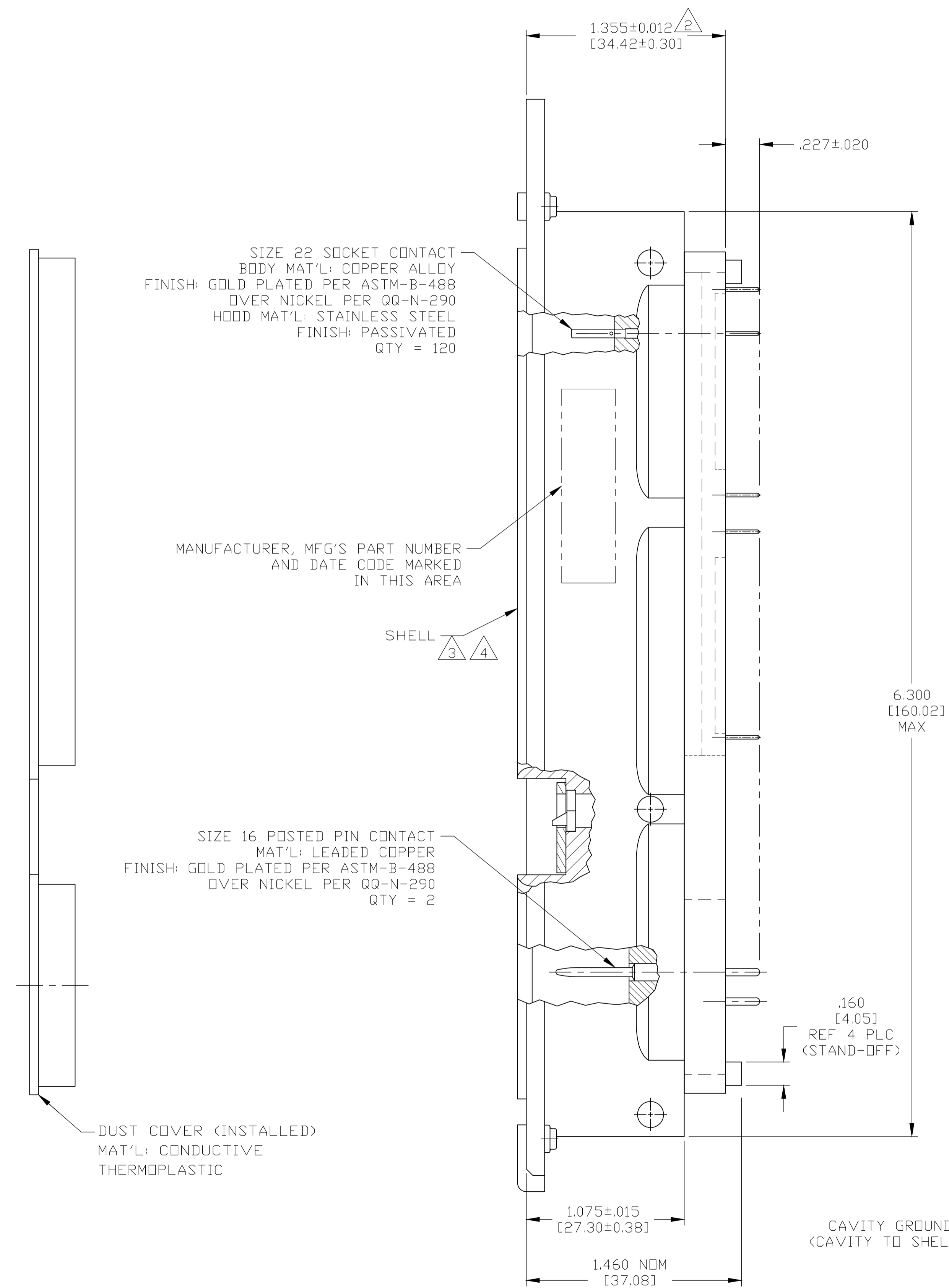
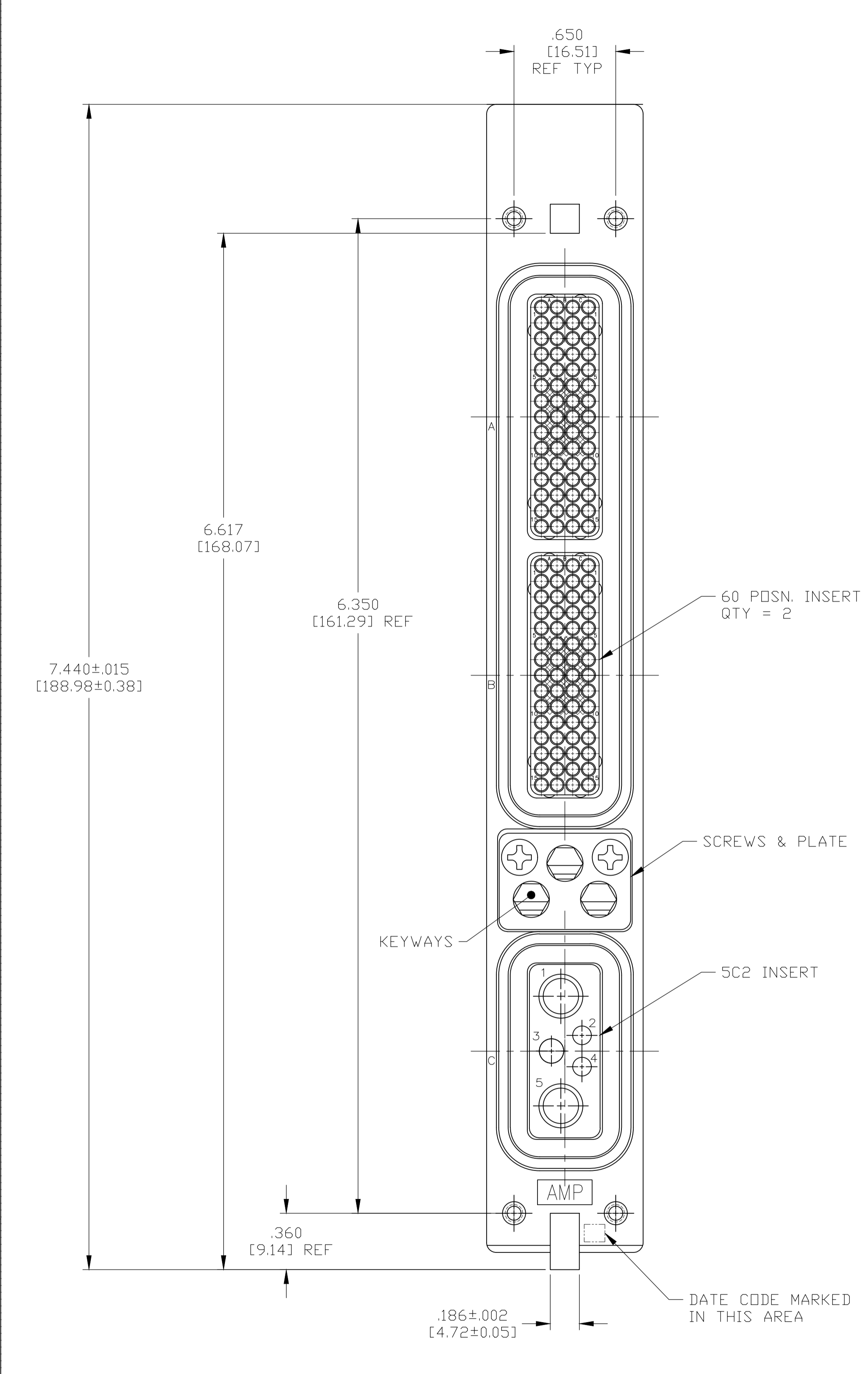

THIS DRAWING IS A CONTROLLED DOCUMENT.		DIN C.C.THOMAS 1-28-03	TE Connectivity Ltd.
DIMENSIONS: INCHES [mm]		CHK LARRY OH 1-28-03	
TOLERANCES UNLESS OTHERWISE SPECIFIED:		APPV LARRY OH 1-28-03	NAME
0 PLC ± -	1 PLC ± -	2 PLC ± -	RECEPTACLE ASSEMBLY, SIZE ONE
3 PLC ± .005 [0.13]	4 PLC ± -	ANGLES ± -	ARINC 600, FRONT RELEASE
MATERIAL SEE CALLOUT	FINISH SEE CALLOUT	WEIGHT -	FILTERED SPECIAL
CUSTOMER DRAWING		SIZE A1	SCALE 2:1
		CAGE CODE 00779	DRAWING NO. 1663302
		SHEET 2 OF 2	REV J