

Broadcom BCM89500/BCM89501 Automotive Switching Technology

Connecting
everything®

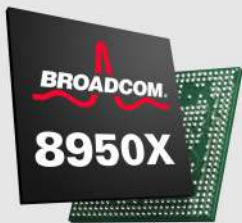

7-PORT INTEGRATED BROADR-REACH® AUTOMOTIVE SWITCH



Highlights

- World's first automotive switch with integrated BroadR-Reach PHYs — which support cost-effective connectivity through lower cabling and connector cost.
- Advanced power savings with Green technology.
- Highly optimized for multiple in-car network applications.
- Enhanced design to meet stringent automotive production requirements.
- Supports various uplink ports for connectivity to external devices and provides flexible port configurations — making it the perfect solution for in-car applications such as advanced driver-assist camera and infotainment systems.

Overview

The BCM89500/BCM89501 devices are Broadcom's first fully integrated BroadR-Reach® multilayer switches to support automotive qualification (AEC-Q100) for in-car networking applications.

The BCM8950X family of products are the optimal solution for key automotive designs that have high-performance yet challenging low-power requirements. Building upon industry-leading 65 nm architecture, the BCM8950X family of products supports multiple intuitive low-power modes as well as an automotive cable diagnostics feature.

Product Family Features

- Specific architectural and design enhancements are utilized to increase design for test, reliability, and quality to surpass AEC-Q100 and EMC requirements.
- Designed to support IEEE 1588 and IEEE 802.1AS timing functions.
- Designed to support both peer-to-peer and end-to-end transparent clocking in hardware.
- Automotive cable diagnostics feature can detect pair open/short and distance.

Architectural Features

- Enhanced architecture supports nonblocking, line-rate data transfer at wirespeed performance for all frame sizes over unshielded single-pair twisted cable.
- Integrated switch core has provisions for the integrated ARM® Cortex™ R4 processor and dedicated on-chip SRAM to send and receive frames.
- Processor subsystem able to support timing stack and AVB bridging support functions.
- Support for Deep Sleep and Ultra Low Power modes, which reduce power consumption to zero during periods of inactivity.

BCM89500/BCM89501

	BCM89500/BCM89501
Automotive	●
Industrial Automation	●
Broadband Access	●

○ Supported ● Best Choice

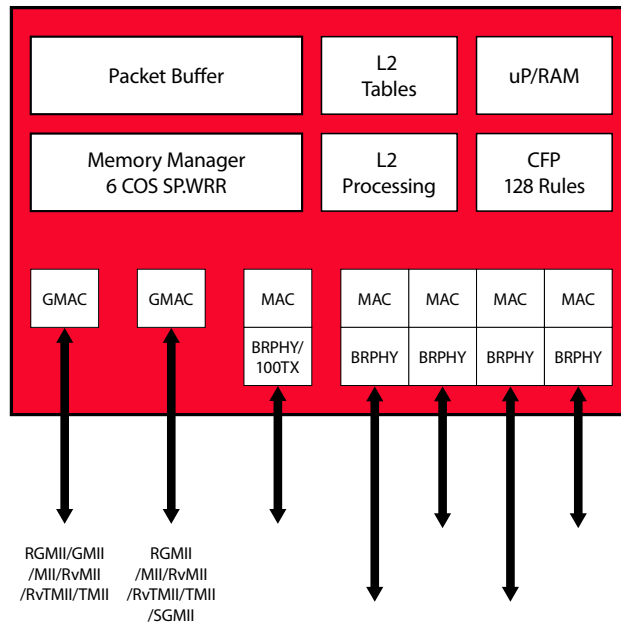

BCM89501 Block Diagram

The BCM8950X family expands Broadcom’s leadership in Ethernet switching technology by delivering an optimized solution for automotive applications requiring nonblocking switching performance

Examples of applications requiring non-blocking switching include multiview advanced driver assist systems, where multiple cameras are connected to a switch in the electronic control unit (ECU), or an infotainment network,

where numerous multimedia endpoints are connected to a head unit.

The BCM8950X product family can interconnect with other devices for scalable, high-performance systems through multiple interfaces including RGMII, GMII, MII, and Turbo MII.

Requirements such as high-precision stereo cameras, rear-seat entertainment units, and multichannel amplifiers are driving the need for adherence to quality of service requirements, specifically highly synchronized and accurate timing.

The BCM89500/BCM89501 devices support IEEE 1588 and IEEE 802.1AS timing functions designed for both peer-to-peer and end-to-end transparent clocking in hardware.

This product family delivers the most comprehensive automotive technology solution required by OEM and Tier 1 suppliers, meeting or exceeding CISPR 25 component-level, ISO 11452-5 Stripline, ISO 11452-4, IEC 61000-4-2, automotive Grade 2 temperature, AEC-Q100, and TS 16949 certifications.

Ordering Information

	Interface	Part Number
176-pin 24 x 24 eLQFP package	4 integrated BroadR-Reach PHYs + 3 uplink ports	BCM89500
176-pin 24 x 24 eLQFP package	5 integrated BroadR-Reach PHYs + 2 uplink ports	BCM89501

About Broadcom

Broadcom Corporation is a major technology innovator and global leader in semiconductors for wired and wireless communications. Broadcom® products enable the delivery of voice, video, data and multimedia to and throughout the home, the office and the mobile environment. We provide the industry's broadest portfolio of state-of-the-art system-on-a-chip and software solutions to manufacturers of computing and networking equipment, digital entertainment and broadband access products, and mobile devices.

These solutions support our core mission: Connecting everything®.

Broadcom, one of the world's largest fabless communications semiconductor companies, with 2010 revenue of \$6.82 billion, holds more than 4,800 U.S. and 2,000 foreign patents, and has more than 7,800 additional pending patent applications, and one of the broadest intellectual property portfolios addressing both wired and wireless transmission of voice, video, data and multimedia.

A FORTUNE 500® company, Broadcom is headquartered in Irvine, Calif., and has offices and research facilities in North America, Asia and Europe. Broadcom may be contacted at +1.949.926.5000 or at www.broadcom.com.

