

THIS DRAWING IS UNPUBLISHED. RELEASED FOR PUBLICATION NOV , 2003.  
 © COPYRIGHT 2003 By - ALL RIGHTS RESERVED.

P	LTR	DESCRIPTION	DATE	DWN	APVD
D1	ECR-18-007914		20JUN2018	ED	RS

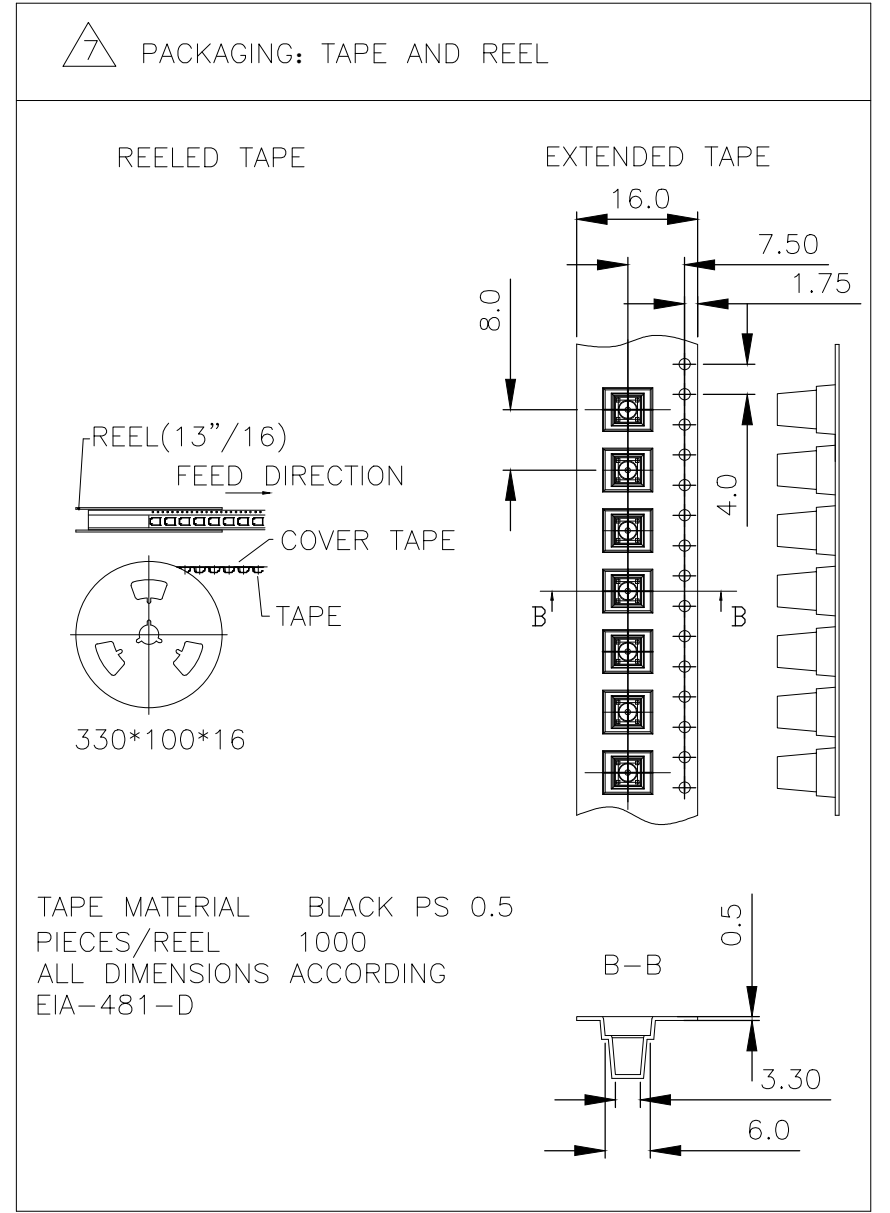
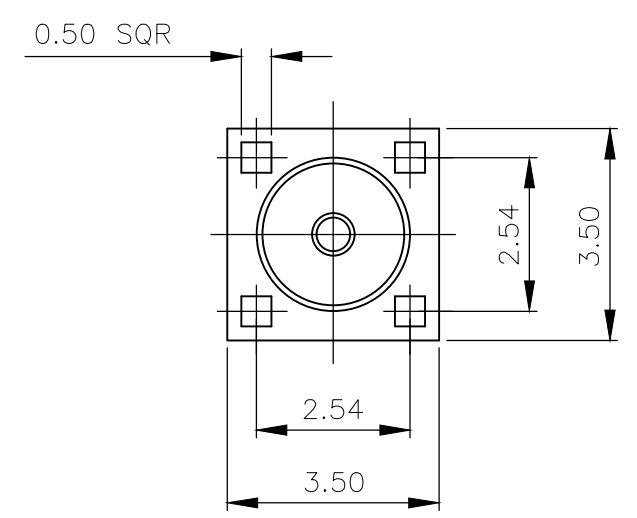
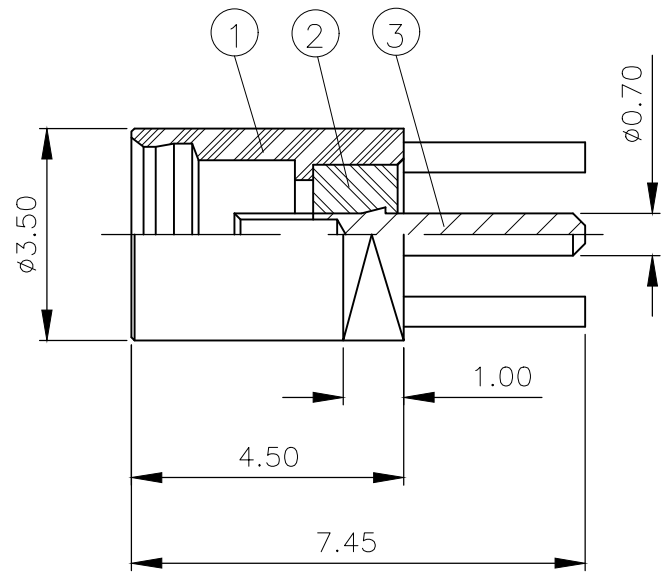

- ① SINGLE PACK: 1PC IN A BAG WITH LABEL; 100 BAGS IN AN INNER BOX WITH LABEL; 20 INNER BOXES IN A CARTON WITH LABEL
- ② 100 PCS IN A TRAY WITH LABEL; 25 TRAYS IN A CARTON WITH LABEL
- ③ Au PLATING
- ④ FLASH Au PLATING

RECOMMENDED PCB LAYOUT

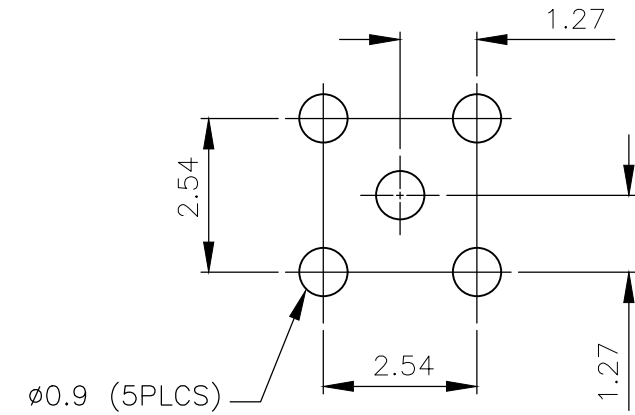

ELECTRICAL CHARACTERISTICS

FREQUENCY RANGE:	DC - 6GHz
NOMINAL IMPEDANCE:	50 Ohm
INSULATION RESISTANCE:	1000MOhm
WORKING VOLTAGE:	335V RMS at Sea Level
DIELECTRIC WITHSTAND VOLTAGE:	500V RMS Max
CONTACT RESISTANCE:	
CENTRE CONTACT:	5.00 MOhm Max
OUTER CONTACT:	2.50 MOhm Max

MECHANICAL CHARACTERISTICS

DURABILITY: 500 Cycles Min

ENVIRONMENTAL CHARACTERISTICS

OPERATING TEMPERATURE: -65°C to +165°C

5 FOR TECHNICAL DATA REFER TO YOUR LOCAL TE CONNECTIVITY SALES OFFICE

6 ALL DIMENSIONS ARE NOMINAL FOR REFERENCE ONLY UNLESS OTHERWISE STATED

QUANTITY PER ASSY	7	2	1	MATERIAL	DESCRIPTION	ITEM
1	1	1	1	BERYLLIUM COPPER ③	SOCKET	3
1	1	1	1	PTFE	INSULATOR	2
1	1	1	1	BRASS ④	BODY	1

THIS DRAWING IS A CONTROLLED DOCUMENT.		DWN J.SANDWELL 12NOV03	TE Connectivity			
DIMENSIONS: mm		CHK S.PARLOW 12NOV03				
TOLERANCES UNLESS OTHERWISE SPECIFIED:		APVD F.WHEELER-KING 12NOV03	NAME			
0 PLC ± - 1 PLC ± 0.3 2 PLC ± 0.2 3 PLC ± 0.1 4 PLC ± - ANGLES ± -		PRODUCT SPEC	MMCX STRAIGHT PCB MOUNT SOCKET RECEPTACLE			
MATERIAL SEE TABLE		FINISH SEE TABLE	50 OHMS			
		APPLICATION SPEC	SIZE	CAGE CODE	DRAWING NO	RESTRICTED TO
		WEIGHT 0.000000	A3	00779	C-1634009	-
		CUSTOMER DRAWING	SCALE NTS	SHEET 1 OF 1	REV D1	