

| | | | |
|--------------------|---------------------------|------------|---|
| PART NUMBER | SSL-LX203CSYT | REV | D |
| DATE | ECN NUMBER | REV | |
| 05.13.04 | E.C.N. # 11126 | | A |
| 12.27.04 | E.C.N. # 11202 | | B |
| 07.26.11 | E.C.N. # 10BRDR & REDRAWN | | C |
| 09.12.17 | ECN-Lumex201700071 | | D |

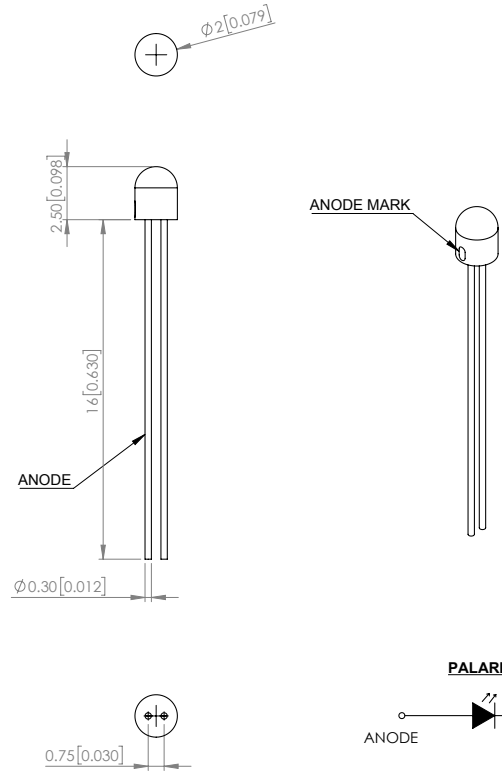

ELECTRO-OPTICAL CHARACTERISTIC TA=25°C

| PARAMETER | MIN | TYP | MAX | UNITS | TEST COND |
|--------------------|-------------|-----|-----|-------------|-----------|
| PEAK WAVELENGTH | - | 590 | - | - | If=20mA |
| FORWARD VOLTAGE | - | 2.1 | 2.5 | Vf | If=20mA |
| REVERSE VOLTAGE | - | - | 5 | Vf | Ir=10uA |
| LUMINOUS INTENSITY | - | 340 | - | mcd | If=20mA |
| VIEWING ANGLE | - | 140 | - | 2x theta1/2 | If=20mA |
| EMITTED COLOR | YELLOW | | | | |
| EPOXY LENS FINISH | WATER CLEAR | | | | |

ABSOLUTE MAXIMUM RATINGS TA=25°C

| PARAMETER | MAX | UNITS |
|-----------------------|----------------|-------|
| STEADY CURRENT | 25 | mA |
| POWER DISIPATION | 62.5 | mW |
| STORAGE TEMPERATURE | -40 to +85 | °C |
| OPERATING TEMPERATURE | -40 to +100 | °C |
| SOLDERING TEMPERATURE | 3sec MAX @ 260 | °C |

*t<10us

PALARITY

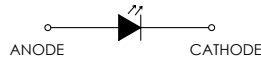

NOTES:

1. ANODE MARK IS INDICATED BY A SMALL MARKING ON THE SIDE OF THE CERAMIC SURFACE. RED MARK INDICATES ANODE.
2. WHITE CERAMIC BASE STEM.

*UNLESS OTHERWISE SPECIFIED TOLERANCES PER DECIMAL PRECISION ARE: X=±1 (±0.039), X.X=±0.5 (±0.020), X.XX=±0.25 (±0.010), X.XXX=±0.127 (±0.005). LEAD SIZE=±0.05 (±0.002), LEAD LENGTH=±0.75 (±0.030), MIN= ^{+0.00}/_{-0.00} DECIMAL PRECISION MAX = ^{+0.00}/_{-0.00} DECIMAL PRECISION



N. GARY AVE.
CAROL STREAM, IL 60188
PHONE : 800-278-5666
FAX : 830-315-2150
WEB : WWW.LUMEX.COM425

T-2 CREAMIC STEM LED, 590nm YELLOW LED, YELLOW TRANSPARENT LENS

"THE SPECIFICATIONS MAY CHANGE AT ANY TIME WITHOUT NOTICE DUE TO NEW MATERIALS OR PRODUCT IMPROVEMENT."

CONFIDENTIAL INFORMATION

THE INFORMATION CONTAINED IN THIS DOCUMENT IS THE PROPERTY OF LUMEX INC. EXCEPT AS SPECIFICALLY AUTHORIZED IN WRITING BY LUMEX INC., THE HOLDER OF THIS DOCUMENT SHALL KEEP ALL INFORMATION CONTAINED HEREIN CONFIDENTIAL AND SHALL PROTECT SAME IN WHOLE OR IN PART FROM DISCLOSURE AND DISSEMINATION TO ALL THIRD PARTIES.

| | |
|-------------------|-----------------|
| DATE : 2017.09.12 | DRAWN BY : E.C. |
| PAGE : 1 OF 1 | CHKD BY : G.Y. |
| SCALE : NTF | APRVD BY : R.C. |
| UNIT : mm [INCH] | (R) |