

Product Document



Datasheet

DS000676

Belago1.1

Dot-Pattern Infrared Illuminator

v1-00 • 2021-Apr-21

Abstract

The Belago1.1 infrared illuminator is the most compact dot-projector for stereoscopic imaging available today. It produces a high-contrast dot pattern that stereo-matching algorithms can use to mitigate the problem of lack of texture, and to produce high-accuracy depth maps.

Belago1.1 enables active stereoscopic imaging to be implemented on a variety of platforms, from robotics to mobile devices.

Content Guide

1	General Description	3	9	Packing Information	15
1.1	Key Benefits & Features.....	3	9.1	Overview.....	15
1.2	Applications	4	9.2	Tray Label.....	15
1.3	Block Diagram	4	10	Soldering & Storage Information	16
2	Ordering Information	5	11	Handling	17
3	Pin Assignment	6	11.1	Pick Up	17
3.1	Pin Diagram.....	6	12	Appendix	18
3.2	Pin Description	6	12.1	RoHS & REACH Compliance.....	18
4	Absolute Maximum Ratings	7	12.2	Safety Advice.....	18
5	Belago1.1 Specification	8	13	Revision Information	19
6	Electrical Characteristics	9	14	Legal Information.....	20
6.1	Typical Operating Characteristics	10			
6.2	Imaging Setup	11			
6.3	Hotspot Detection	11			
7	Mechanical Drawings.....	12			
8	Application Information	14			
8.1	PCB Pad Layout and Solder Mask Recommendation	14			
8.2	Orientation of the Field of Illumination.....	14			

1 General Description

1.1 Key Benefits & Features

Stereoscopic imaging systems often suffer from impaired performance when the scene lacks features: an example is a flat, smooth surface such as a wall. In such cases, the 3D information captured by stereoscopic imaging systems is typically incomplete or inaccurate. Furthermore, the search for features in the images often results in high computational loading.

ams has developed a unique, proprietary solution to this problem. The Belago1.1 infrared illuminator, the most compact dot-projector for stereoscopic imaging available today, produces a high-contrast dot pattern that stereo-matching algorithms can use to mitigate the problem of lack of texture, and to produce high-accuracy depth maps. The presence of the infrared pattern also reduces considerably the computational load imposed by the software, as it offers many features to facilitate matching of the left and right images.

Belago1.1 enables active stereoscopic imaging to be implemented on a variety of platforms, from robotics to mobile devices.

Belago1.1 provides a feedback loop, integrated on the lens, that allows monitoring of a lens or package damage by the operating platform.

Belago1.1 provides an improved non-periodic pattern for single IR illuminator camera configurations.

The benefits and features of Belago1.1, Dot-Pattern Infrared Illuminator for 3D Stereoscopic Imaging, are listed below:

Figure 1:
Added Value of Using Belago1.1

Benefits	Features
Small package size	4.2 mm x 3.6 mm x 3.325 mm
Module height compatible with integration in mobile platforms	3.325 mm ± 0.05
Power efficient	High optical efficiency, high VCSEL efficiency
Easy component mounting	Standard lead-free solder reflow compatible
Randomized high density, high contrast dot pattern	Optimized for active stereo vision systems
Eye Safety interlock	Integrated feedback loop on the lens

1.2 Applications

- Active stereo 3D sensors
- Integrated mobile 3D sensors
- Integrated tablets and all-in-one 3D sensors
- Front-facing and world-facing 3D cameras

1.3 Block Diagram

The functional blocks of this device are shown below:

Figure 2 :
Functional Blocks of Belago1.1

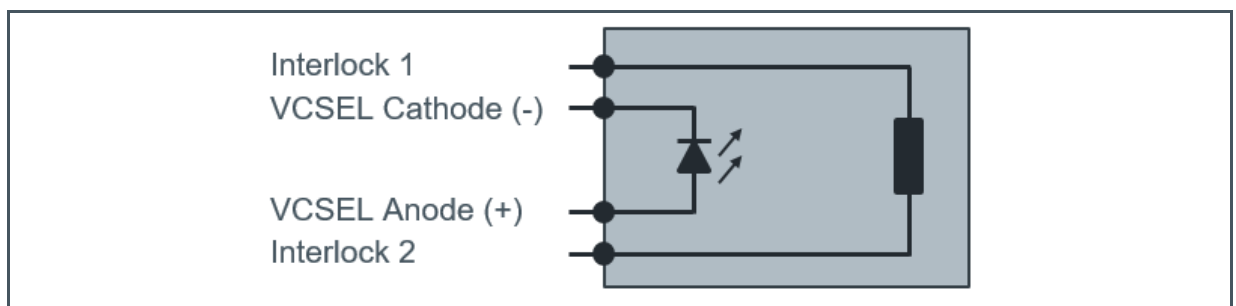

2 Ordering Information

Ordering Code	Description	Delivery Form	Delivery Quantity
AQAA-20	Belago1.1 Dot Pattern Illuminator	Tray	490 pcs per tray

3 Pin Assignment

3.1 Pin Diagram

Figure 3:
Module Bottom View

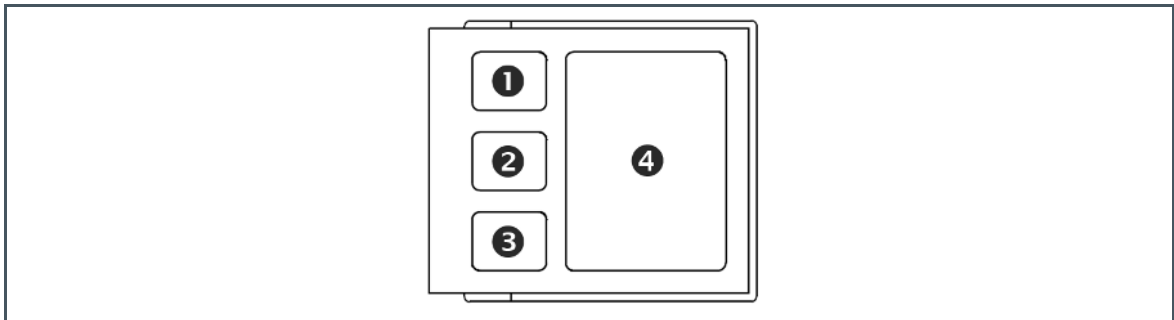

3.2 Pin Description

Figure 4:
Pin Description of Belago1.1

Pin Number	Pin Name	Description
1	Sense 1	Resistive Interlock connection
2	Anode	VCSEL Power
3	Sense 2	Resistive Interlock connection
4	Cathode	VCSEL Power

4 Absolute Maximum Ratings

Stresses beyond those listed under “Absolute Maximum Ratings” may cause permanent damage to the device. These are stress ratings only. Functional operation of the device at these or any other conditions beyond those indicated under “Operating Conditions” is not implied. Exposure to absolute maximum rating conditions for extended periods may affect device reliability.

Figure 5
Absolute Maximum Ratings of Belago1.1

Symbol	Parameter	Min	Max	Unit	Comments
Electrical Parameters					
V_F	Forward Voltage		3	V	25 °C, Pulse >10 nsec
I_F	Forward Current		7	A	25 °C, Pulse >10 nsec
I_{rev}	Reverse Current		10	μ A	25 °C instantaneous
Continuous Power Dissipation ($T_{Case} = 70\text{ °C}$)					
P_T	Continuous Power Dissipation		1000	mW	Input power
Temperature Ranges and Storage Conditions					
T_{STRG}	Storage Temperature Range	- 40	80	°C	
T_{Op}	Operating Temperature	0	80	°C	IPC/JEDEC J-STD-020
MSL	Moisture Sensitivity Level		3		JESD22-A113D

5 Belago1.1 Specification

Figure 6:
Individual Emitter Characteristics

Parameter	Condition	Min	Typ	Max	Unit
Horizontal FOI 50% (deg)	Full width half max.	57	61	65	deg
Vertical FOI 50% (deg)	Full width half max.	74	78	82	deg
Number of dots	@Camera FOV 56°x74°		4700		Dots
Contrast ⁽¹⁾		15			
Wavelength	@ 350 mA, 25 °C	932	940	948	nm
Spectral width	Full width half max @ 350 mA, 25 °C	0	1.5	3	nm
Wavelength shift with temperature			0.065	0.075	nm/°C
Thermal resistance	@100% duty cycle		26		K/W
Operating temperature	Heat sink temperature	10		60	°C
Storage temperature		-40		80	°C

(1) Contrast is defined as the ratio of the 95th percentile of the dot intensity over the median intensity of the background.

Figure 7:
Other General Characteristics

Parameter	Value
Light Source	VCSEL
Pattern Rotation	15° ±1.5° (testing value)
Dimensions (X Y Z) (mm ³)	4.2 x 3.6 x 3.325
Electrical Contacts	Anode, cathode and interlock on backside
Number of Electrical Contacts	1x cathode and 1x anode 2x sense
Assembly Type	Reflow compatible

6 Electrical Characteristics

All limits are guaranteed. The parameters with Min and Max values are guaranteed with production tests or SQC (Statistical Quality Control) methods.

Figure 8:
Electrical Characteristics of Belago1.1

Symbol	Parameter	Conditions ⁽¹⁾	Min	Typ	Max	Unit
I_{op1}	Operating current	At RT, 10 ms / 30 fps		350		mA
P_{op1}	Operating power	At $I_{op}=350$ mA At RT, 10 ms / 30 fps	200	250	280	mW
V_{op1}	Operating voltage	At $I_{op}=350$ mA At RT, 10 ms / 30 fps	1.6		2.2	V
I_{op2}	Operating current	At RT, 1 ms / 30 fps		425		mA
P_{op2}	Operating power	At $I_{op}=425$ mA At RT, 1 ms / 30f ps	260	300	340	mW
V_{op2}	Operating voltage	At $I_{op}=425$ mA At RT, 1 ms / 30 fps	1.6		2.3	V
PCE_{op}	Operating PCE	At $I_{op}=350-425$ mA At RT, 1 ms / 30 fps	32	37		%
Duty cycle	PWM control			5	30	%
$R_{interlock}$	Resistance	At RT	10.8	13	21	kOhm
t_{rise}	Rise time				5	ns
I_{th}	Threshold current	At RT, CW	32		130	mA

- (1) Specified temperatures refer to the emitter case temperature (the emitter is mounted on a temperature-controlled stage); RT stands for Room Temperature (25 °C).
- (2) Pulsed operating condition as reference parameter set.

6.1 Typical Operating Characteristics

Figure 9:
Electro-Optical Performance

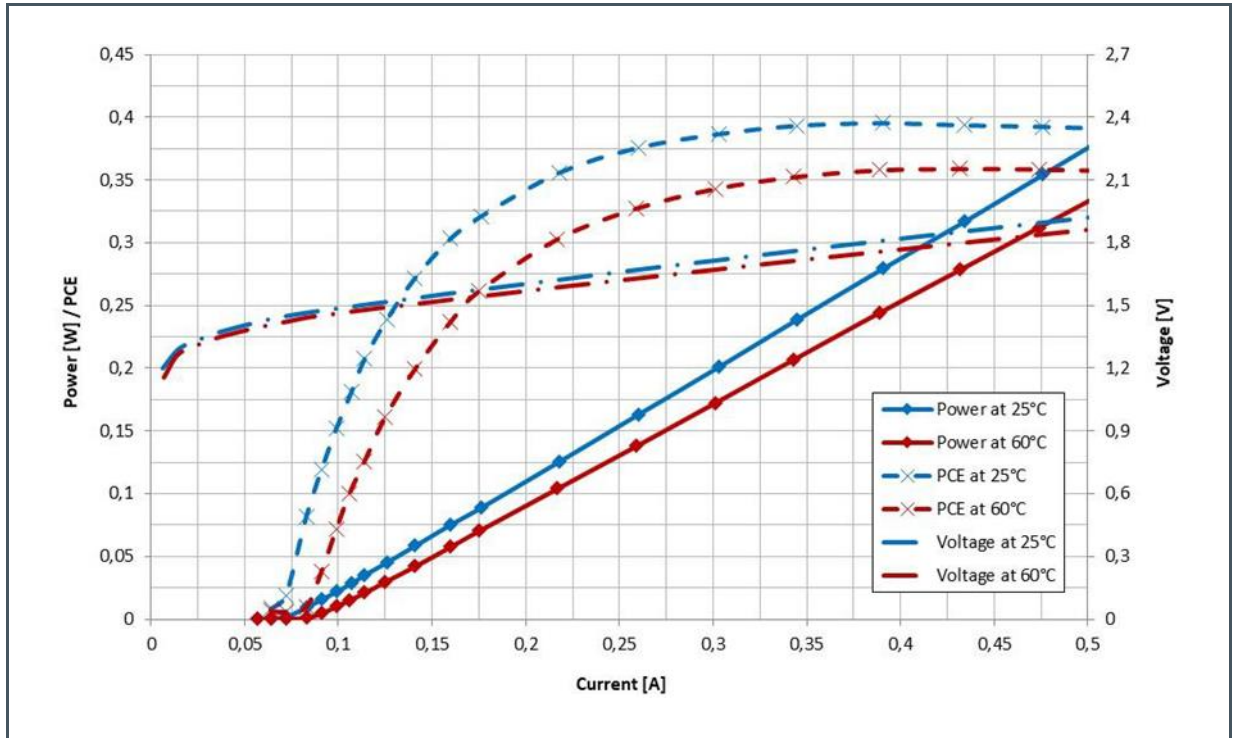
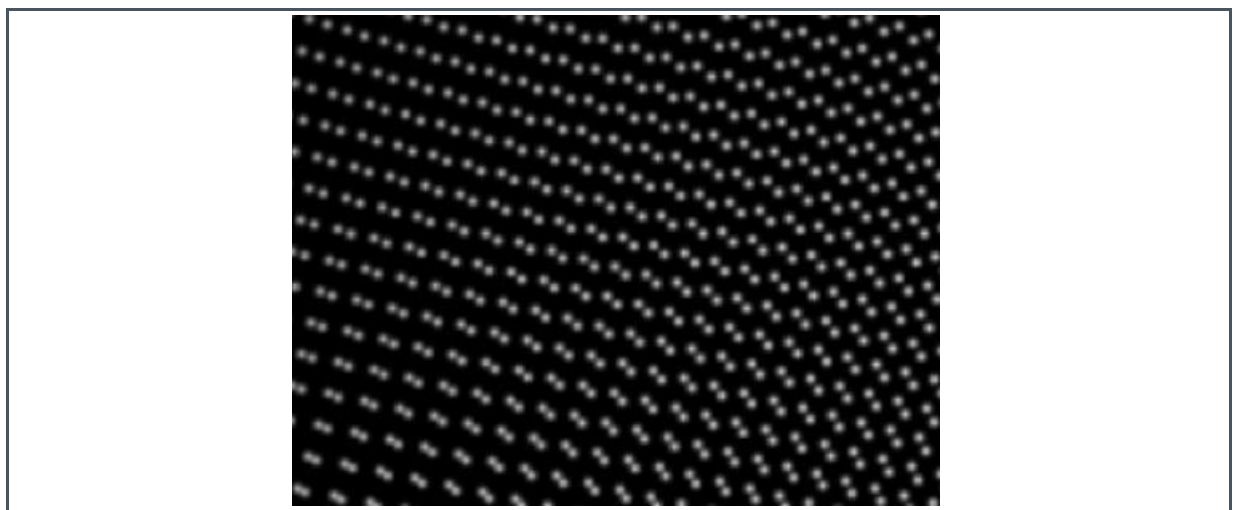

Figure 10:
Projected Dot Pattern



(1) Projected dots pattern measured from Belago1.1 (cropped image showing a magnified section of the FOI)

6.2 Imaging Setup

For the pattern characterization, the output is projected onto a white, matte-finished target board (Lambertian surface), at a distance. Images are taken inside a dark chamber with a monochrome CCD camera and a wide angle objective.

6.3 Hotspot Detection

Every individual Belago1.1 module is inspected during production to detect the presence of hotspots and similar non-uniformities that cause excessive brightness of the infrared pattern and could be harmful to the human eye.

7 Mechanical Drawings

Figure 11:
Package Dimensions

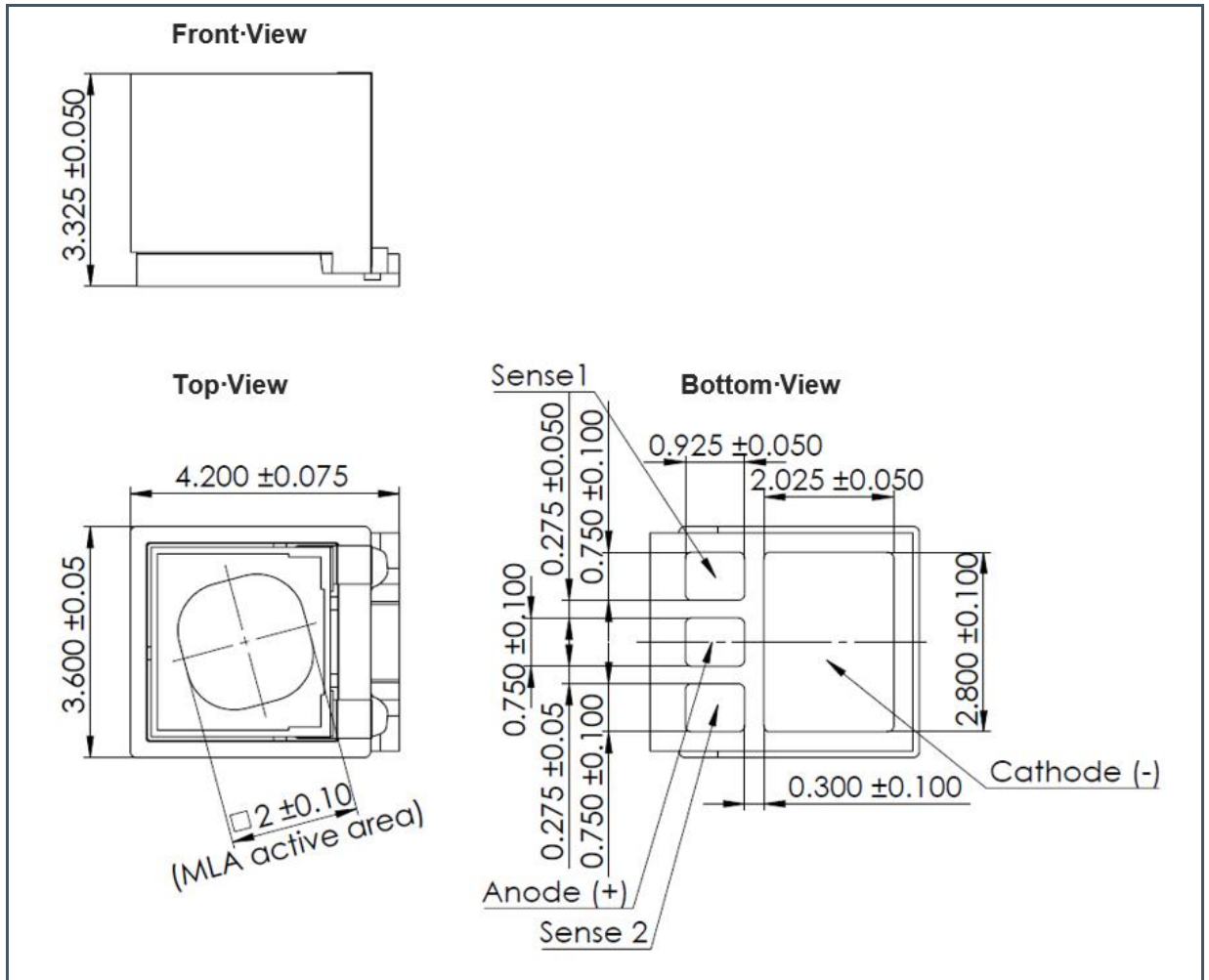

- (1) Outline dimensions Belago1.1
- (2) All dimensions in mm

Figure 12:
3D View

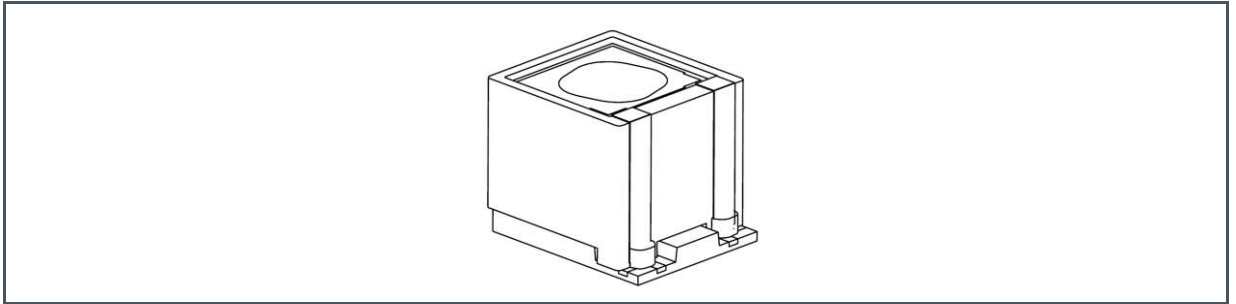
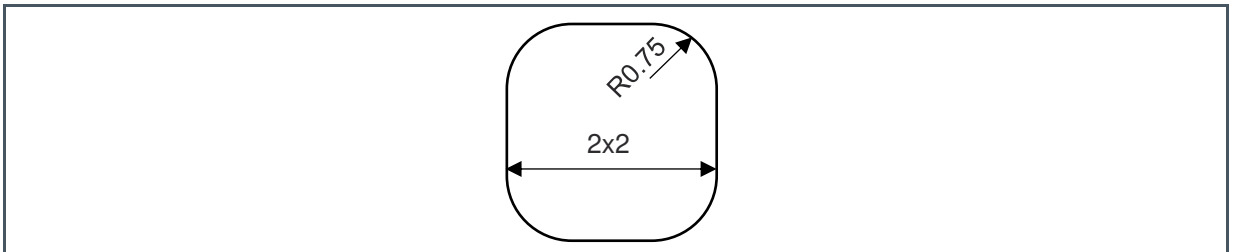
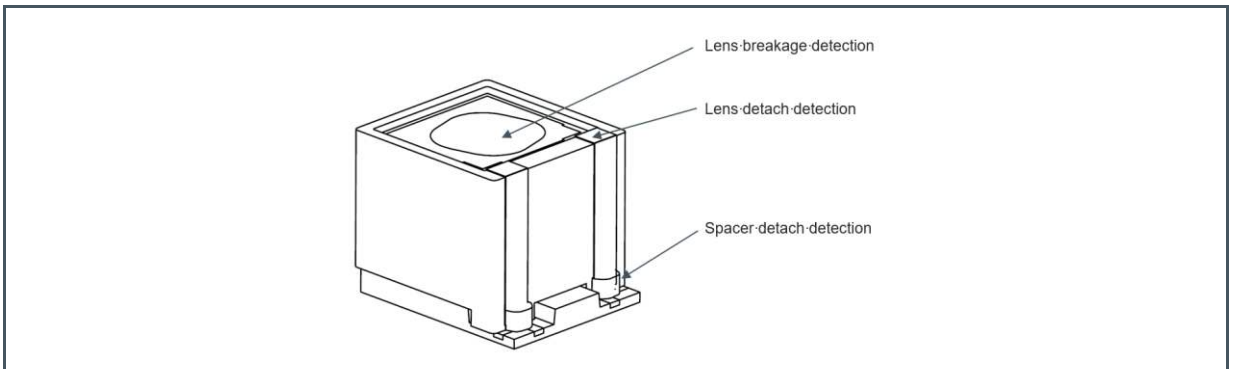

Figure 13:
Optical Aperture



- (1) Optical aperture dimensions (defining the opening where the light is emitted through).
- (2) All dimensions in mm

Figure 14:
Safety Interlock



- (1) Conductive loop covering the optical active area of the lens and connecting to the bottom side pads for module integrity monitoring. A damage of the module results in an open circuit.
- (2) Resistance value should be in the specified range when module is operated, to ensure the functioning of the interlock

8 Application Information

8.1 PCB Pad Layout and Solder Mask Recommendation

The drawings below are showing a recommendation for pad layouts and solder mask. This is only to be used as guide and not to be considered as a firm specification.

Figure 15:
Solder Mask Layout

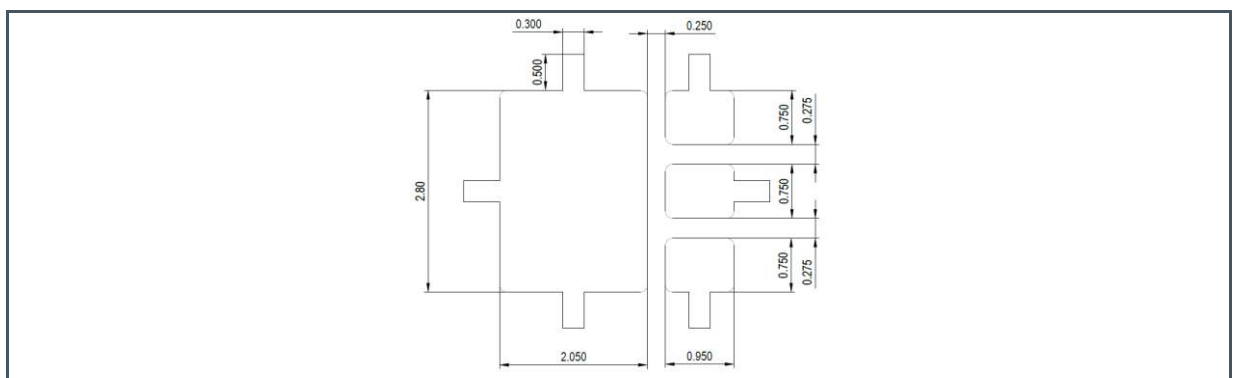

(1) All dimensions in mm

8.2 Orientation of the Field of Illumination

Figure 16:
FOI Orientation

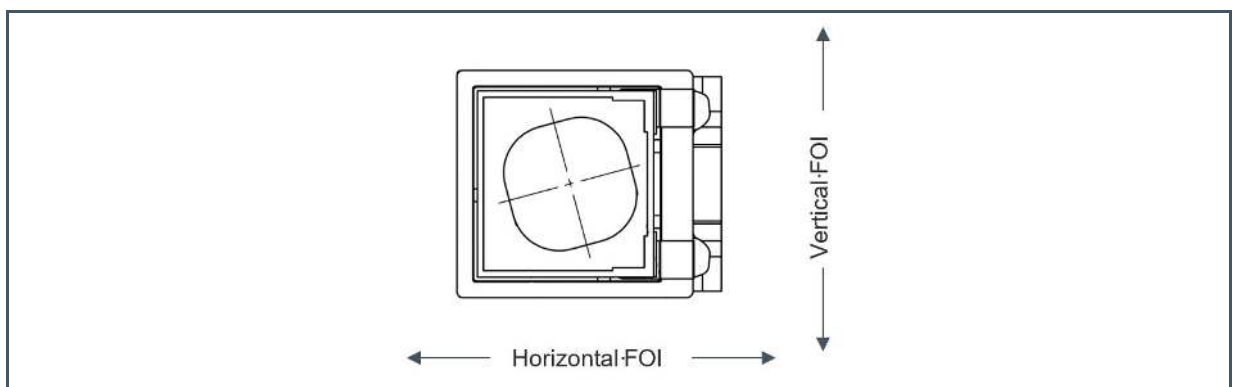

(1) Orientation of the Field of Illumination with respect to the Belago1.1 module.

9 Packing Information

9.1 Overview

Figure 17:
Shipping Tray Dimensions and Overview

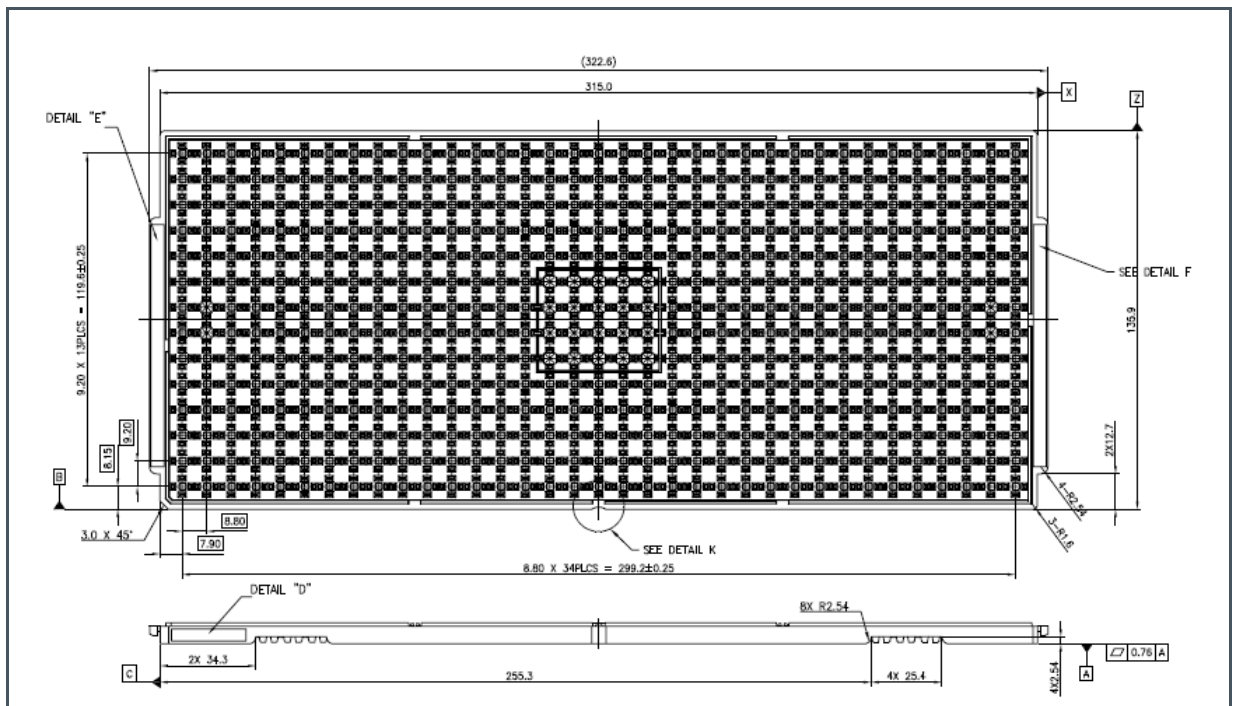

(1) All dimensions in mm

9.2 Tray Label

Trays are individually labeled. The label information is as follows:

- Part number (XXXX-XX)
- Tray ID
- Quantity
- Shipment date
- Manufacturing country

10 Soldering & Storage Information

Belago1.1 modules have been tested for lead-free solder reflow compatibility with peak temperatures up to 250 °C (MSL3).

An example reflow profile is provided in Figure 18. The exact reflow profile may depend on exact solder used.

An example of solder paste that can be used is Tamura LFSOLDER TLF-204-NH(20-38).

Figure 18:
Solder Reflow Profile Graph

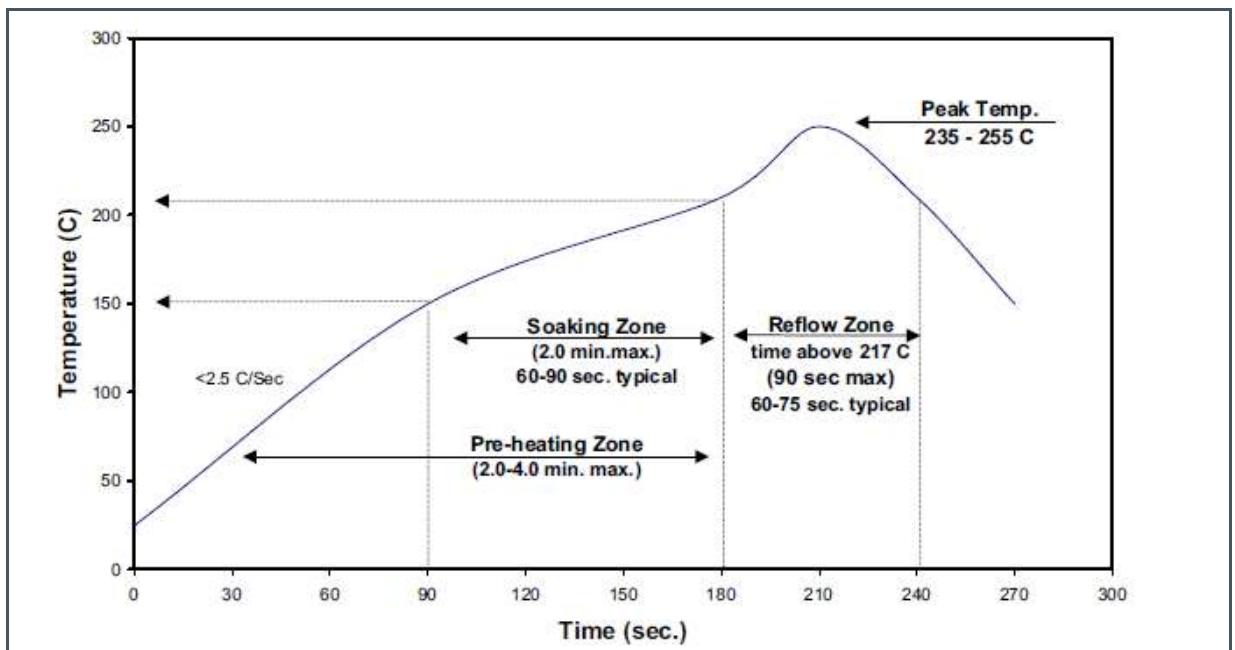

Attention

The module contains a ventilation hole to allow pressure equalization with the ambient.

It is not advised to proceed to cleaning after SMT reflow process.

The modules **MUST NOT** be cleaned using ultrasonic cleaning.

We suggest to use flux free solder paste and not to clean after SMT.

In case a cleaning is un-avoidable, rinse with DI water, followed by a 2h bake @70 °C

11 Handling

11.1 Pick Up

Recommended pick up position on the top window (green circle), touching directly the glass.

Figure 19:
Pick Up Location

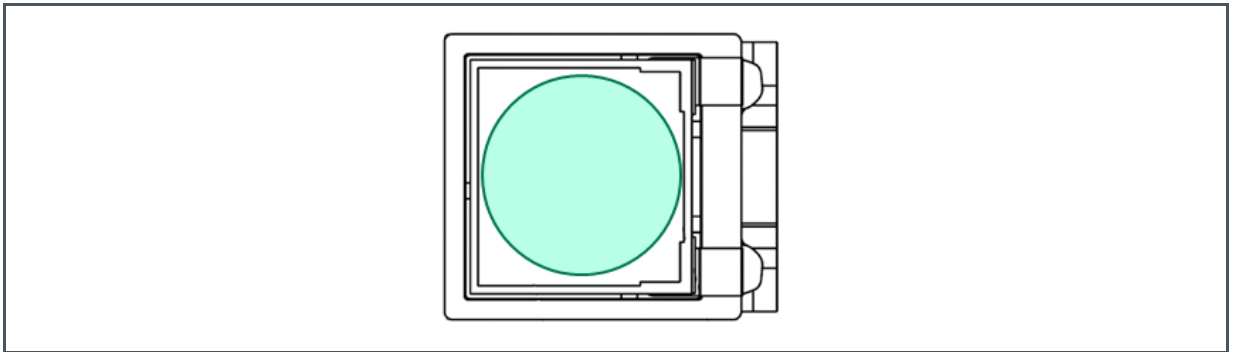

(1) Picking area within green area

12 Appendix

12.1 RoHS & REACH Compliance

The Belago1.1 module is compliant with the European RoHS Directive 2002/95/EC (Restriction of the Use of Certain Hazardous Substances in Electrical and Electronic Equipment) and REACH (Registration, Authorization and Restriction of Chemicals, European Union Regulation (EC) 1907/2006).

12.2 Safety Advice

Depending on the operational use of the device, the modules can emit highly concentrated non-visible infrared light, which can be hazardous to the human eyes. Products incorporating these modules may have to follow the safety precautions described by IEC 60825-1:2014.

This product emits infrared radiation and has not yet been classified under IEC 60825-1:2014. All appropriate safety precautions should be exercised in the operation and use of this product.



CAUTION

Avoid direct eye exposure except as may be determined and directed by Purchaser.
Appropriate protective eyewear should be worn when operating.
Use of magnifying optical instruments with this component may increase eye hazard.



LASER PRODUCT
LASER RADIATION – AVOID DIRECT EYE EXPOSURE
WAVELENGTH: 940nm
MAXIMUM OUTPUT POWER: Depends on drive mode
WEAR PROTECTIVE GLASSES

14 Legal Information

Copyrights & Disclaimer

Copyright ams AG, Tobelbader Strasse 30, 8141 Premstaetten, Austria-Europe. Trademarks Registered. All rights reserved. The material herein may not be reproduced, adapted, merged, translated, stored, or used without the prior written consent of the copyright owner.

Devices sold by ams AG are covered by the warranty and patent indemnification provisions appearing in its General Terms of Trade. ams AG makes no warranty, express, statutory, implied, or by description regarding the information set forth herein. ams AG reserves the right to change specifications and prices at any time and without notice. Therefore, prior to designing this product into a system, it is necessary to check with ams AG for current information. This product is intended for use in commercial applications. Applications requiring extended temperature range, unusual environmental requirements, or high reliability applications, such as military, medical life-support or life-sustaining equipment are specifically not recommended without additional processing by ams AG for each application. This product is provided by ams AG "AS IS" and any express or implied warranties, including, but not limited to the implied warranties of merchantability and fitness for a particular purpose are disclaimed.

ams AG shall not be liable to recipient or any third party for any damages, including but not limited to personal injury, property damage, loss of profits, loss of use, interruption of business or indirect, special, incidental or consequential damages, of any kind, in connection with or arising out of the furnishing, performance or use of the technical data herein. No obligation or liability to recipient or any third party shall arise or flow out of ams AG rendering of technical or other services.

RoHS Compliant & ams Green Statement

RoHS Compliant: The term RoHS compliant means that ams AG products fully comply with current RoHS directives. Our semiconductor products do not contain any chemicals for all 6 substance categories plus additional 4 substance categories (per amendment EU 2015/863), including the requirement that lead not exceed 0.1% by weight in homogeneous materials. Where designed to be soldered at high temperatures, RoHS compliant products are suitable for use in specified lead-free processes.

ams Green (RoHS compliant and no Sb/Br/Cl): ams Green defines that in addition to RoHS compliance, our products are free of Bromine (Br) and Antimony (Sb) based flame retardants (Br or Sb do not exceed 0.1% by weight in homogeneous material) and do not contain Chlorine (Cl not exceed 0.1% by weight in homogeneous material).

Important Information: The information provided in this statement represents ams AG knowledge and belief as of the date that it is provided. ams AG bases its knowledge and belief on information provided by third parties, and makes no representation or warranty as to the accuracy of such information. Efforts are underway to better integrate information from third parties. ams AG has taken and continues to take reasonable steps to provide representative and accurate information but may not have conducted destructive testing or chemical analysis on incoming materials and chemicals. ams AG and ams AG suppliers consider certain information to be proprietary, and thus CAS numbers and other limited information may not be available for release.

Headquarters

ams AG
Tobelbader Strasse 30
8141 Premstaetten
Austria, Europe
Tel: +43 (0) 3136 500 0

Please visit our website at www.ams.com

Buy our products or get free samples online at www.ams.com/Products

Technical Support is available at www.ams.com/Technical-Support

Provide feedback about this document at www.ams.com/Document-Feedback

For sales offices, distributors and representatives go to www.ams.com/Contact

For further information and requests, e-mail us at ams_sales@ams.com