

REVISIONS					
REV	ECO	DESCRIPTION	DATE	BY	APPR
A1	-	RELEASE	30MAR2017	JAH	-
A2	-	UPDATED HOOD GEOMETRY & REEL DIR.	26AUG2020	JAH	-
A3	C1298S	UPDATE PLATING	14/SEP/20	SULLEN	TOMMY

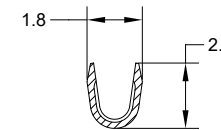

SECTION A-A

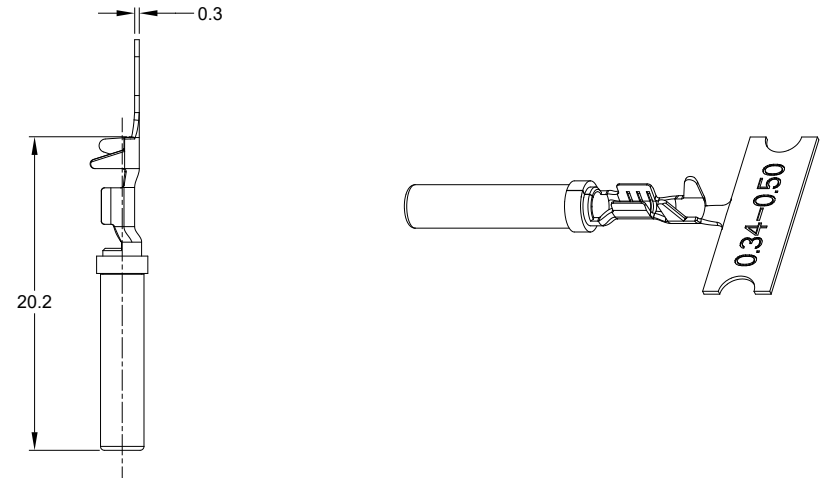
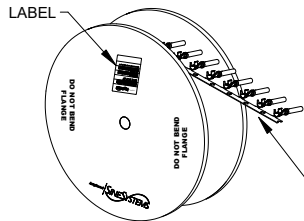
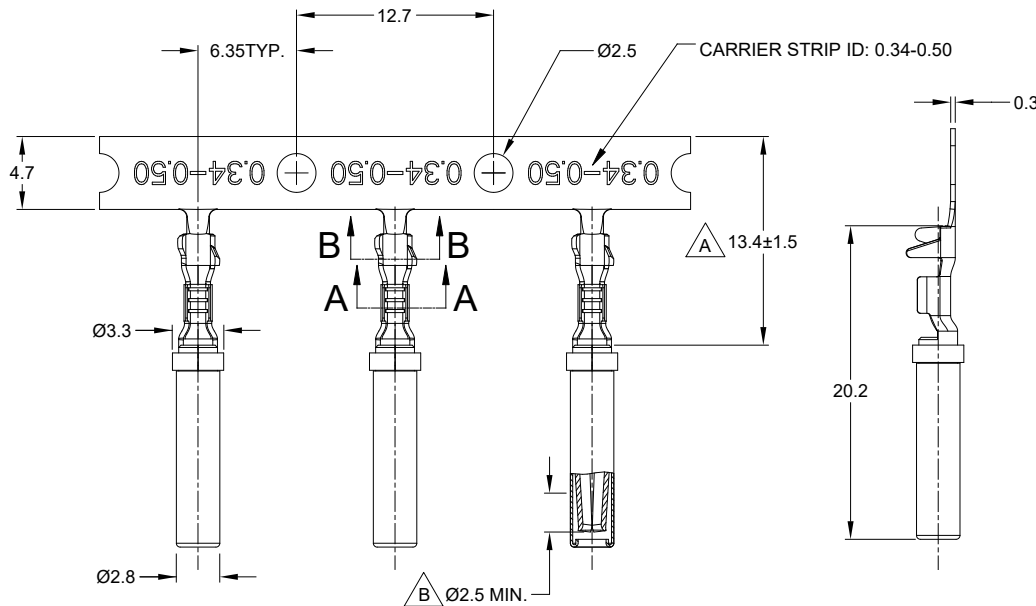
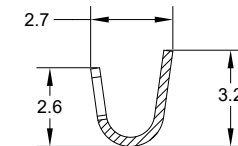

SECTION B-B

NOTES: UNLESS OTHERWISE SPECIFIED

- MATERIAL: COPPER ALLOY
- PLATING: SEE PART NUMBER CHART
- CONTACT SIZE: 16
- SPECIFICATIONS:
 - CURRENT RATING: 13 AMPS
 - CONTACT MILLIVOLT DROP: 100 MILLIVOLT DROP @ 13 AMP TEST CURRENT.
 - RoHS COMPLIANT
- RECOMMENDED WIRE RANGE: 20 - 22 AWG (0.5 - 0.35mm²)
RECOMMENDED INSUL O.D: 1.31 - 1.50MM (0.051 - 0.059INCH)
- PACKAGE: 4000 PCS/REEL
- ALL DIMENSIONS ARE FOR REFERENCE USE ONLY

PART NUMBER CHART		
PLATING	PART NUMBER	PLATING DESCRIPTION
NICKEL	AT62-16-0822	SELECTIVE TIN OVER NICKEL OVERALL IN Δ ZONE
GOLD	AT62-16-0844	SELECTIVE GOLD FLASH OVER NICKEL OVERALL IN ∇ ZONE OR ENTIRE CONTACT
TIN	AT62-16-0877	TIN OVER NICKEL OVERALL

SEE CHART		DESCRIPTION		ITEM								
QUANTITY	PART NUMBER	MATERIALS LIST										
UNLESS OTHERWISE SPECIFIED 1) All dimensions are in metric (mm). 2) Tolerances are as follows: 1 PL DEC ±0.30 2 PL DEC ±0.15 3 PL DEC ±0.08 3) Note reference = Δ		SIGNATURES DRAWN: SULLENZhang CHECKED: ORIONLI ENGINEER: APPROVAL: TOMMY.XIE CUSTOMER:		DATE 14/SEP/20 15/SEP/20 18/SEP/20								
MATERIAL SPECIFICATIONS:		<p>Sine Systems - www.amphenol-sine.com 44724 Morley Drive Clinton Township, MI 48036</p>										
PROCESS SPECIFICATIONS:		CONTACT, SOCKET, STAMPED, SIZE 16, 20-22 AWG, AT & AHD-9 SERIES										
NEXT ASSY:		THIS DRAWING IS SUPPLIED FOR INFORMATION ONLY. DESIGN FEATURES, SPECIFICATIONS AND PERFORMANCE DATA SHOWN HEREON ARE THE PROPERTY OF THE AMPHENOL CORPORATION. NO RIGHTS OF REPRODUCTION ARE IMPLIED. ALL DIMENSIONS ARE SUBJECT TO NORMAL MANUFACTURING VARIATIONS.	<table border="1"> <tr> <th>SIZE</th> <th>TYPE</th> <th>DWG NO.</th> <th>REVISION</th> </tr> <tr> <td>B</td> <td>C-</td> <td>AT62-16-08XX</td> <td>A3</td> </tr> </table>	SIZE	TYPE	DWG NO.	REVISION	B	C-	AT62-16-08XX	A3	SCALE: NONE
SIZE	TYPE	DWG NO.	REVISION									
B	C-	AT62-16-08XX	A3									
		SHEET 1 OF 1										

TITLE: CONTACT, STAMPED, SIZE 16, 20-22 AWG, AT & AHD-9 SERIES
DWG NO.: AT62-16-08XX
REV: A3
SH: 1
OF: 1