

## DESCRIPTION

The EV3389EY-00A is an evaluation board for the MP3389EY, a step-up converter designed for large liquid-crystal displays that employ an array of LEDs as the light source. It can drive up to 12 strings LEDs in parallel with 60mA maximum current.

The MP3389 uses external power MOSFET and internal current mode, fixed frequency architecture and includes current ballast in each string terminal, which achieves 2.5% current regulation accuracy between strings. Low feedback voltage at each LED string help reduce power loss and improve efficiency.

The MP3389 has multiple features to protect the converter from fault conditions, including under-voltage lockout, current limiting, over voltage, short LED, open LED and thermal shut-down protection.

## ELECTRICAL SPECIFICATIONS

Parameter	Symbol	Value	Units
Input Voltage	$V_{IN}$	8 – 28	V
LEDs #		12 strings parallel and 14 LEDs/string	
LED Current	$I_{LED}$	20/string	mA

## FEATURES

- 8V to 28V Input Voltage Range
- External Power MOSFET
- Up to 90% Efficiency
- Programmable Over Voltage Protection
- Drives up to 12 Strings Parallel 2.5% Current Regulation Accuracy Between Strings
- Programmable Switching Frequency:
- PWM or DC Input Burst PWM Dimming
- Open and Short LED Load Protection
- Thermal Shutdown

## APPLICATIONS

- Notebook PC
- LCD Monitor
- LCD TV
- Handy Terminals Display
- Automotive Systems and Tablet Computer

"MPS" and "The Future of Analog IC Technology" are Registered Trademarks of Monolithic Power Systems, Inc.

## EV3389EY-00A EVALUATION BOARD

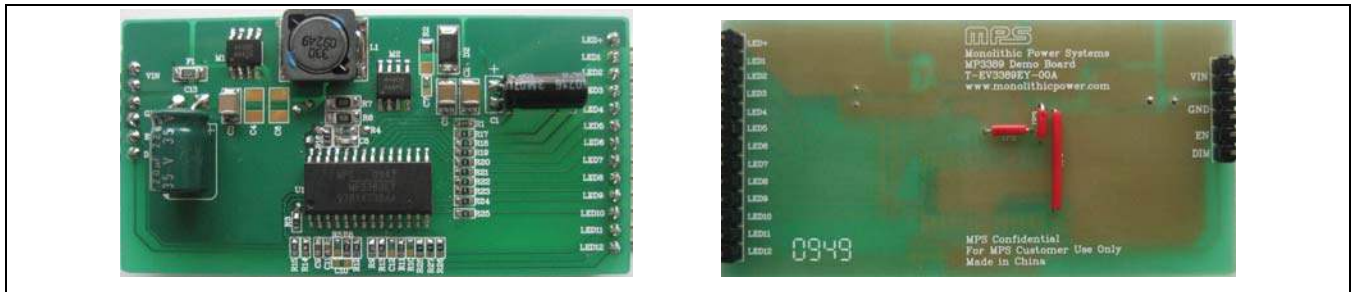

(L x W x H) 7.5cm x 3.8cm x 1.0cm

Board Number	MPS IC Number
EV3389EY-00A	MP3389EY

EVALUATION BOARD SCHEMATIC

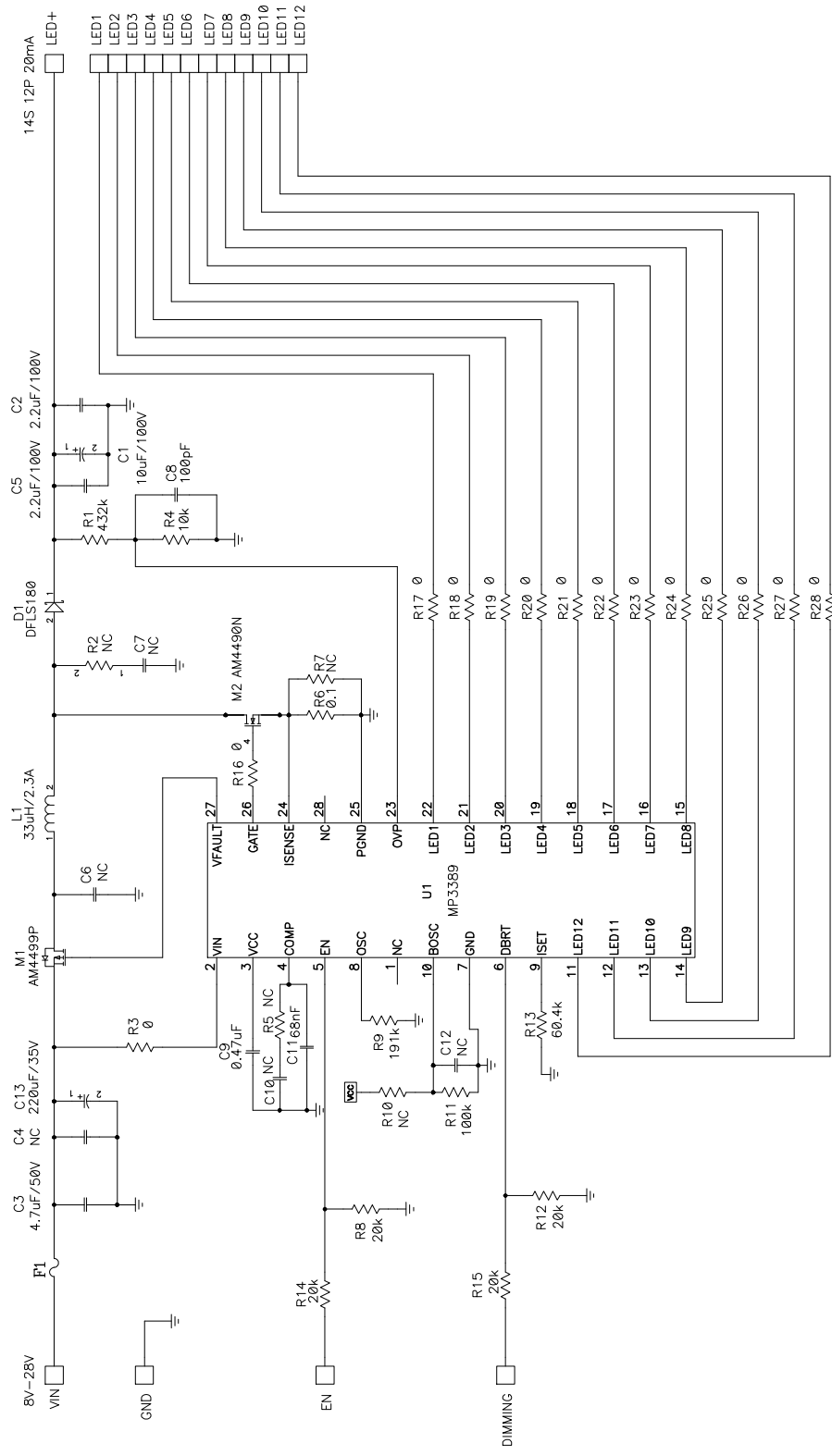

**EV3389EY-00A BILL OF MATERIALS**

Qty	Ref	Value	Description	Package	Manufacturer	Part Number
1	C1	10 $\mu$ F	Electrolytic Capacitor, 100V			
2	C2,C5	2.2 $\mu$ F	Ceramic Capacitor, 100V, X7R	1210	Murata	GRM32ER71H225KA88L
1	C3	4.7 $\mu$ F	Ceramic Capacitor, 50V, X7R	1210	Murata	GRM32ER71H475KA88L
2	C4,C6	NC		1210		
3	C7,C10, C12	NC		0603		
1	C8	100pF	Ceramic Capacitor, 50V, COG	0603	Murata	GRM1885C1H101JA01D
1	C9	0.47 $\mu$ F	Ceramic Capacitor, 50V, X7R	0603	Murata	GRM1885C1H474JA01D
1	C11	68nF	Ceramic Capacitor, 50V, X7R	0603	Murata	GRM188R71H683KA93D
1	C13	220 $\mu$ F	Electrolytic Capacitor, 35V			
1	D1		Diode Schottky, 90V, 1A	SMA	Diodes Inc	B190
1	F1	0 $\Omega$	Fuse, 2A, 63V	1206	Cooper Bussman	3216FF2-R
1	L1	22 $\mu$ H	Inductor,2.6A	SMD	Sumida	CDRH8D43-220N
		33 $\mu$ H	Inductor,2.3A	SMD	Toko	
1	M1		P- channel MOSFET	SO8		AM4499P
1	M2		N- channel MOSFET	SO8		AM4490N
1	R1	432k $\Omega$	Resistor, 1%	0603	Yageo	RC0603FR-07432KL
3	R2,R5, R10	NC		0603		
14	R3,R16~R28	0 $\Omega$	Resistor, 1%	0603	Yageo	
1	R4	10k $\Omega$	Resistor, 1%	0603	Yageo	RC0603FR-0710KL
2	R6	0.1 $\Omega$	Current Resistor, 1%	1206		
1	R7	NC		1206		
4	R8,R12, R14,R15	20k $\Omega$	Resistor, 1%	0603	Yageo	RC0603FR-0720KL
1	R9	191k $\Omega$	Resistor, 1%	0603	Yageo	RC0603FR-07191KL
1	R11	100k $\Omega$	Resistor, 1%	0603	Yageo	RC0603FR-07100KL
1	R13	60.4k $\Omega$	Resistor, 1%	0603	Yageo	RC0603FR-0760K4L
1	U1		LED Driver IC	TSSOP28	MPS	MP3389EY

## PRINTED CIRCUIT BOARD LAYOUT

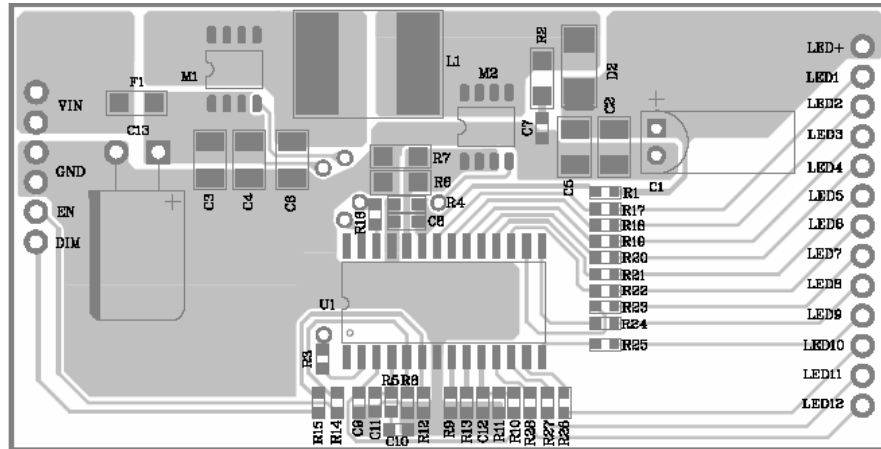

Figure 1—Top Layer

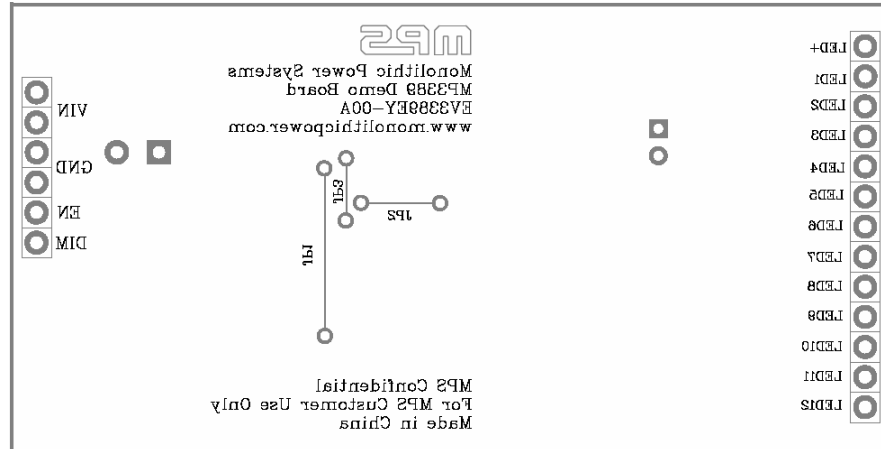

Figure 2—Bottom Layer

## QUICK START GUIDE

1. Connect the positive and negative terminals of the load panel (14 white LEDs in series, 12 strings paralleled) to the LED+ and LED1~12 pins on the EV board, respectively.
2. Connect the positive and negative terminals of the power supply (8V ~ 28V) to the VIN and GND pins on the EV board, respectively.
3. Drive EN pin high (5V) to enable the MP3389.
4. For PWM dimming, apply a PWM rectangular waveform with a minimum voltage less than 0.5V and a maximum greater than 5V on PWM DIM pin. The frequency of the PWM signal is recommended between 200Hz to 2kHz.

**NOTICE:** The information in this document is subject to change without notice. Users should warrant and guarantee that third party Intellectual Property rights are not infringed upon when integrating MPS products into any application. MPS will not assume any legal responsibility for any said applications.